

AS1603/AS1703/AS1803R

**AC BRIDGE SYSTEM
DYNAMIC STRAIN AMPLIFIERS**

INSTRUCTION MANUAL

Cautions

- Read carefully before using this product.
- Place this manual within reach of the AS series amplifier.

INTRODUCTION

▲Before Using▼

We would like to express our thanks to you for your purchase of our product strain amplifier AS series. Please read this manual carefully before operating this instrument.

This manual provides the information necessary to operate the instrument safely. This manual covers basic functions and operations of the AS amplifiers and handling precautions. Place this manual within reach of the AS series amplifier. If you encounter any problems in the manuals, please contact our sales representative.

▲Examining Contents in Package▼

If opening the package in a warm room during the cold season, open the package after it has reached room temperature to avoid any operational failure due to condensation on the surface of the product.

The warranty does not apply for the case where damages or faults caused by use against instructions, warnings, or cautions.

This instrument is delivered after a thorough examination at the factory prior to shipment. However, please examine the product's condition and verify that no obvious shipping damage has occurred after opening the package. Also, examine the specifications of the input units and accessories. If there are any missing or damaged items, please contact our sales representative.

▲Cautions▼

- The contents of this manual are subject to change without notice.
- This manual is copyrighted with all rights reserved. No parts of this manual may be transcribed or reproduced without written permission.
- Please let us know if there are any points that are unclear or missing in this manual.
- We do not assume any responsibility for the outcome of the use of the AS series amplifier.

PRECAUTIONS

To avoid accidents, read this manual carefully before use. Observe the following warning and cautions when using amplifiers. The warranty does not apply any damage caused by the use against instructions, warnings, and cautions. To safely use the amplifiers, the following statements are used in this manual to call the readers' attention.

WARNING

This indicates a condition or practice that could result in personal injury or loss of life, or may result in light injury or physical damage if this equipment is misused due to neglect of a Warning

CAUTION

This indicates a condition or practice that could result in light injury or damage to the equipment or other property if this equipment is misused due to neglect of a Caution.
In order to avoid electrical shock or burning, confirm that no common mode voltage or signal is applied to the signal wire when the signal wire is connected

WARNING

• **Power Supply**

Make sure that the power supply is within the rating. If any voltage exceeding the rated voltage were supplied, there would be risk of damage to this amplifier, or even a fire. Also, in order to prevent electric shock and hazards such as a fire, be sure to use only the AC power cable supplied with this amplifier.

• **Protective Grounding**

Be sure to ground this amplifier before supplying power. Grounding is necessary to use this amplifier safely, as well as to protect the user and peripheral equipment from injury or damage. Be sure to observe the following instructions:

1) Protective grounding

This product uses a 3-pole power cable, which has grounding. Always connect to the power outlet having grounding.

2) Caution on protective function

While the power is supplied to the amplifier, do not cut or remove the protective grounding line. Otherwise, safety of the amplifier is not guaranteed.

3) Protective function failure

Avoid using this product when there is a failure in protective grounding or protective functions. Confirm that there is no failure in the protective function before using.

• **Use in Gaseous Atmosphere**

Never use this amplifier in a flammable or explosive atmosphere, or atmosphere of steam. Use in such atmosphere will result in danger to users and the amplifier.

• **Disassembling the Frame**

It is dangerous to remove the frame. Do not remove the frame from the amplifier other than 100VAC/200VAC switching using the selection switch.

• **Input Signal Connection**

Connect the signal wire to the input terminal after connecting protective grounding terminal to the ground. When connecting the signal wire, check whether the signal wire is being properly protected from leak signals from the environment or common-mode voltage in order to avoid electrical shock or burning.

• **Cautions during Operation**

Be careful of operations because large voltage might be applied between the input terminal (input signal wire) and ground of this amplifier or input terminal and output terminal (output signal wire).

• **Installation Category and Contamination Level**

The AS series amplifiers are devices with Installation Category II and Contamination Level II. Use them following the regulations defined in Installation Category II and Contamination Level II.

CAUTION

• Caution in Handling

When using this amplifier, always follow the precautions below.

1) Users

Users who are not familiar with the operation of this recorder should avoid using it.

2) Use and storage environment

The storage temperature and humidity of the input units is -10 to 70°C and 10 to 90%, respectively. Avoid storing in places where the temperature could rise over the storage temperature and where there is direct sunlight exposure such as inside an automobile.

Do not use this recorder at the following locations.

1. Locations where the temperature and humidity rise due to direct sunlight or heaters. (The operating environment of the amplifier; temperature: -10 to 50°C , humidity: 20 to 85%)
2. Wet locations
3. Locations where salt, oil, or corrosive gases exist
4. Damp or dusty locations
5. Locations subject to strong vibrations

3) Cautions on power supply

1. Be careful of power voltage fluctuations. Do not use the amplifier when these are likely to exceed the rated voltage.
2. If the power supply includes a lot of noise or high-voltage inductive noise, use noise filters to avoid operation errors.

4) Calibration

We recommend a periodical calibration to maintain the accuracy. More reliable measurements are possible by calibrating the amplifier once a year (extra cost option).

CAUTION IN HANDLING

Read this manual carefully before using the amplifier.

1. Do not apply neither voltage nor current to the output terminal of this amplifier from external source.
2. Use this amplifier with power supply voltages from 85 VAC to 132 VAC, 180 VAC to 264 VAC, or 10 VDC to 30 VDC. The AC power supply selection switch is provided inside the chassis. To switch the AC power supply voltage, refer to page 7-4. If the power fuse is burnt, check the cause of fuse blow-out. To replace the fuse, always disconnect the power plug and input/output signal cable first, and then replace the fuse in the fuse holder. For how to replace fuse, see page 7-3. When replacing, examine the ratings of fuse (e.g. for AC or DC).
3. The operation temperature and humidity of the input units is -10 to 70°C and 10 to 90%, respectively. If opening the package in a warm room during the cold season, open the package after it has reached room temperature to avoid any operational failure due to condensation on the surface of the product.
 - Do not use this instrument at the following locations.
 - High-humidity locations
 - Locations with direct sunlight exposure
 - In the vicinity of high-temperature heat source
 - Location with vibrations
 - Locations where salt, water, oil, or corrosive gases exist
4. When using many amplifier units, install fan units.
5. When a case is used to accommodate amplifiers, the case must be grounded.
6. This product uses a flash memory for saving setup values. Replacement of battery is not needed accordingly.
7. As the AS series amplifiers have AC signal bridge voltage. Amplifier unit whose bridge voltage frequency differs cannot be used in the same case. In addition, when using several units closely, always make synchronization. Otherwise, noises may be generated. See 3-8 and 3-9 for details.
8. This amplifier unit uses rotary encoders are used for knobs to control functions. However, indication position of the knob sometimes stays at the position between scale markings. In such case, the settings upon power-up may differ from those upon turning off the amplifier. To avoid such event, it is recommended to allow knob indication to be at the correct scale marking position.

WARRANTY

We ship our products after conducting quality control, which covers from design to manufacturing. It is, however, possible that failures may occur in the products. If the product does not operate correctly, please make a check of the power supply, cable connections, or other conditions before returning this product to us. For repair or calibration, contact our sales representative. Before returning, be sure to inform us of the model, serial number, and problematic points. The following is our warranty.

LIMITED WARRANTY

1. Warranty period

Two years from our shipment.

2. Warranty limit

We will repair the defects of our product free of charge within the warranty period; however, this warranty does not apply in the following cases.

- (1) Damage or faults caused by incorrect use.
- (2) Damage or faults caused by fire, earthquake, traffic accident, or other natural disasters.
- (3) Damage or faults caused by a repair or modification that is carried out by someone other than a service representative of A&D COMPANY,LIMITED.
- (4) Damage or faults caused by use or storage in environmental conditions that should be avoided.
- (5) Periodical calibration.
- (6) Damage or faults caused during transportation.

3. Liability

We do not assume any liabilities for equipment other than A&D COMPANY,LIMITED..

Disposing of your used our product



- Disposing of your used our product -

In the European Union

EU-wide legislation as implemented in each Member State requires that used electrical and electronic products carrying the must be disposed of separately from normal household waste. This include electrical accessories, such as chargers or AC The mark on the electrical and electronic products only applies the current European Union Member States.

Outside the European Union

If you wish to dispose of used electrical and electronic outside the European Union, please contact your local authority and ask for the correct method of

TABLE OF CONTENTS

Before Using	1
Examining Contents in Package	1
Cautions	1
PRECAUTIONS	
PRECAUTIONS	2
Warning	3
Caution	4
Cautions In Handling	
Cautions In Handling	5
Warranty	
Warranty	6
Limited Warranty	6
Disposing of your used our product	
Disposing of your used our product	7
Table of Contents	8 to 10
1.Overview	
1.1 Features	1-1
1.2 Amplifier Unit and Case	1-1 to 1-2
1.3 Accessories	1-2
1.4 Block Diagram of Measurement	1-2
1.5 Features of Dynamic Strain Amplifiers	1-3
2. Names and Functions of Parts	
2.1 Names and Functions of Parts on Front Panel	2-1 to 2-4
2.2 How to Set Calibration Value	2-5
2.3 Indication upon Balancing	2-6
2.4 Names and Functions of Parts on Rear Panel	2-7 to 2-8
3. Before Measuring	
3.1 Cable Connections	3-1
3.1.1 Input Cable Connections	3-1
3.1.2 Connections of Power Supply Cable and Output Cable	3-2
3.2 Operation before Measuring	3-2

3.2.1 Standalone Operation	3-2 to 3-3
3.2.2 Measuring Range	3-4
3.3 Bridge Check Function	3-5
3.3.1 Overview	3-5
3.3.2 Error Indication List upon Wire Disconnection and Short	3-6
3.4 Cable Length Compensation Function	3-7 to 3-8
3.5 How to Switch Special Function Setting	3-9
3.6 Cases	3-10
3.6.1 Names of Case Elements	3-10
3.6.2 How to Use Case	3-10 to 3-13
3.6.3 Synchronization between Old-type Case and New-type Case	3-13 to 3-14
3.6.4 Heat Release for Case	3-14 to 3-15

4. Measurement

4.1 Cautions before Measuring	4-1 to 4-2
4.2 Input Connection	4-2
4.2.1 Examples of Strain Gauge Bridge Configurations	4-2 to 4-4
4.2.2 Bridge Box	4-5 to 4-6
4.2.3 Measurement with Transducer	4-7
4.3 Connection of Output to Load	4-8
4.3.1 Connection of Output to Data Recorder	4-8 to 4-9
4.4 How to Read Measured Values	4-9 to 4-10
4.4.1 Correction of Calibration (CAL) Values	4-10 to 4-11
4.5 Special Applications	4-12
4.5.1 Slip Ring	4-12
4.5.2 Differential Transformer	4-12

5. Operation Theory

5.1 Flow of Measured Signal	5-1
-----------------------------------	-----

6. Optional Functions

6.1 Current Output (AS16-201 4 to 20 mA output unit)	6-1
6.2 Case Function and Type	6-1
6-2-1 Accommodating amplifier units	6-2
6-2-2 How to Mount Blank Panels	6-2
6-2-3 Connecting Ground Wire	6-2
6-2-4 Cautions on Rack-mount Case	6-2

7. Maintenance

7.1 Items to Be Checked	7-1 to 7-2
7.2 How to Replace Fuse	7-3
7.3 Changing AC Power Supply Voltage	7-4

8.Specifications

8.Specifications	8-1 to 8-2
------------------------	------------

9. References

9.1 Frequency and Phase Characteristics	9-1 to 9-2
9.2 Cable List	9-3 to 9-4
9.3 Dimensional outline drawing	9-5
9.3.1 Unit	9-5
9.3.2 Panel cut sizes	9-6
9.3.3 Bench-top Case	9-7
9.3.4 Rack-mount Case	9-8
9.3.5 Fan Unit	9-9
9.3.6 Bridge Box (5370)	9-10

1. OVERVIEW

1.1. Features

The AS1000 series are amplifiers that inherit the superior performance in conventional amplifiers. Moreover they features new functions such as cable length compensation and bridge checking, realizing higher-accuracy and higher-quality measurement and a reduction in measurement preparation time. All models in the AS series include an LED monitor and the auto-balancing function, thereby improving their operability. Table 1-1 introduces three AC strain amplifiers models, AS1603, AS1703, AS1803R which permit strain gauge-type transducers to perform physical value measurement.

Another feature of the AS1603, AS1703, AS1803R amplifiers are their lead-free and battery-less product design. When several amplifier units are installed in a case, power supply, auto-balancing, calibration value input, and key-locking for all amplifier units can be made by one operation. If you encounter any problem, read the section for maintenance, and contact with our sales representative if the problem is not solved.



Multipurpose Type	Multipurpose and High Response Type	Anti-Surge Type
		
AS1603	AS1703	AS1803R

Table1-1 AC Strain Amplifier

1.2 Amplifier Unit and Case

The table below summarizes the specifications of dynamic strain amplifiers AS1000 series. The sensitivity is based on $BV = 2V$.

TYPE	BV	Balance	Frequency	Sensitivity (BV=2V)	Main Application
AS1603	ACV	AUTO	DC~2kHz	$10V/200 \times 10^{-6}$ Strain	Strain Measurement
AS1703	ACV	AUTO	DC~10kHz	$10V/500 \times 10^{-6}$ Strain	
AS1803R	ACV	AUTO	DC~2kHz	$10V/200 \times 10^{-6}$ Strain	

Table1-2 Main Specifications for AC Strain

AS1603, AS1703, AS1803R can use the following optional devices and cases.

Product	Type	Items	Remarks
Bench Top Case	AS16-104	4CH Bench Case	±CAL, BAL, KEYLOCK, and batch ON/OFF for all units are available
	AS16-105	6CH Bench Case	
	AS16-106	8CH Bench Case	
Rack-mounting Case	AS16-107	8CH Rack-mount Case	

Table1-3 List of optional devices

1.3 Accessories

- Output cord (0311-2057) x 1
- Time-lag fuse
(Fuse for AC power supply: 85 to 132VAC/180 to 264VAC, 100mA: 0334-3006 x 1)
(Fuse for DC power supply: 10V to 30VDC, 500mA: 0334-3013 x 1)
- Screwdriver x 1
- AC power cord (0311-5044)
- Instruction Manual x 1

1.4 Block Diagram of Measurement

The following diagram illustrates a typical measurement system that broadly covers a variety of factors including signal amplitude, frequencies, and measuring time.

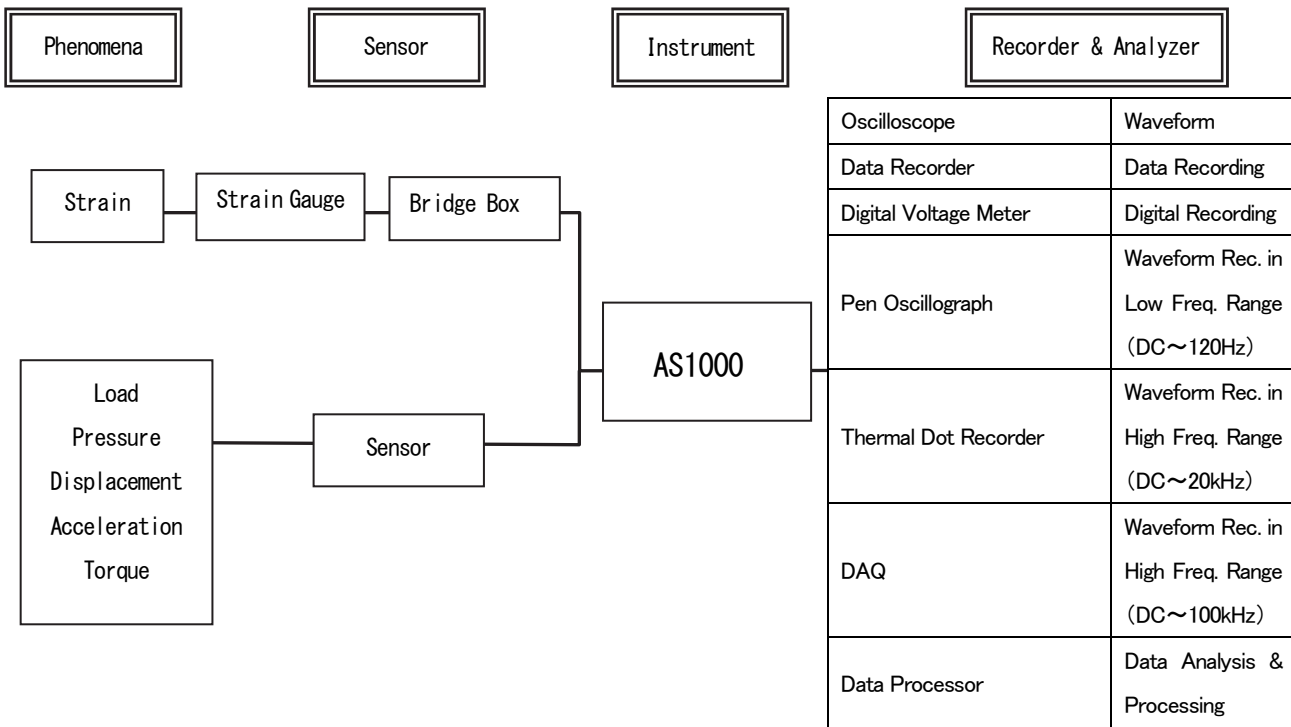

Fig.1-1 Block diagram for Measuring

1.5 Features of Dynamic Strain Amplifiers

Bridge power voltage supply	AC bridge (AC strain amplifier)
Recommended sensors	1. Strain gauges 2. Sensors for load, displacement, acceleration, and torque (Strain gauge-type transducers)
Features	AC strain amplifiers have higher S/N ratio and higher sensitivity than those of DC strain amplifiers. However, for non-linearity and frequency response, AC strain amplifiers does not exhibit higher performance. Because the AC strain amplifiers do not include commercial power source that may generate noises in the amplifying range, these amplifiers have high anti-noise characteristics. This feature is advantageous in measurement using strain a gauge.

Table 1-4 Recommended Sensors and Features

TYPE	AC Strain Amplifier		
	AS1603	AS1703	AS1803R
Voltage Sensitivity	$\pm 10V$ at $\pm 200 \times 10^{-6}$ Strain	$\pm 10V$ at $\pm 200 \times 10^{-6}$ Strain	$\pm 10V$ at $\pm 200 \times 10^{-6}$ Strain
Nonlinearity	$\pm 0.1\%$ / FS	$\pm 0.2\%$ / FS	$\pm 0.1\%$ / FS
Frequency Response	DC ~ 2kHz	DC ~ 10kHz	DC~ 2kHz
Noise	2.0×10^{-6} Strain p-p	6.0×10^{-6} Strain p-p	2.0×10^{-6} Strain p-p
Max. Gain	50,000	20,000	50,000
Bridge Voltage	AC Voltage 0.5,2V		
Strain Gauge	Optimum	Optimum	Optimum
Strain Gauge Type Transducer	Adequate	Adequate	Adequate
Strain Measurement under the field faced with the worrying situation of serge voltage	Adequate	Adequate	Optimum
Long Distance between sensor and instrument	Optimum	Optimum	Optimum
Impact Strain	Inadequate	Inadequate	Inadequate
DC Amplifier	Inadequate		

Table1-5 Choice of models

2. NAMES and FUNCTIONS OF PARTS

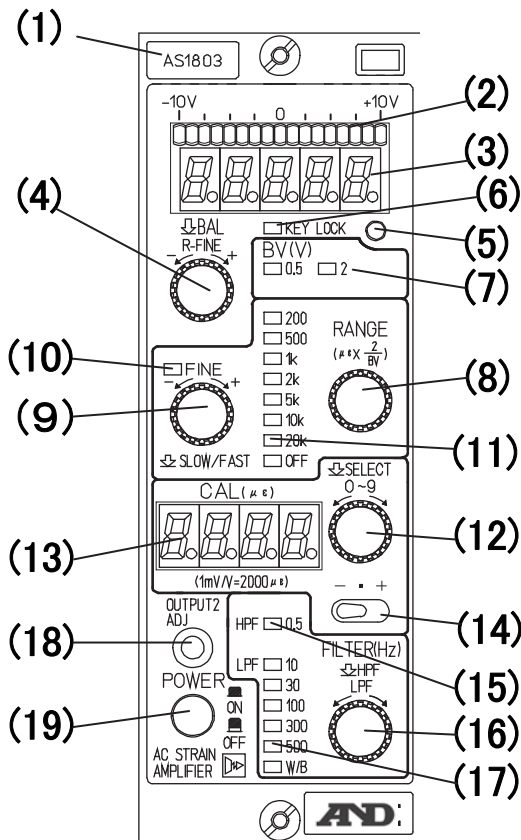

Fig.2-1 Face of panel

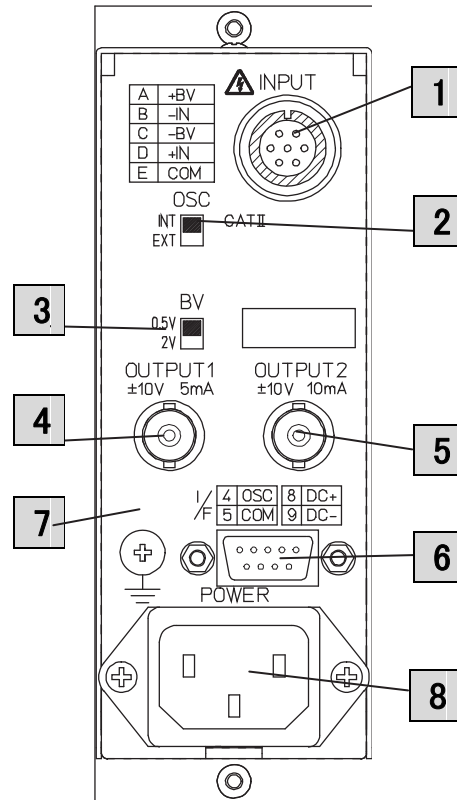

Fig.2-2 Back face

2.1 Names and Functions of Parts on Front Panel (See Table 2-1)

Number	Name	Function
(1)	Model	Model indication
(2)	Level meter (17-dot LED)	This level meter monitors the output voltage of OUTPUT 1 [4]. The green LED at the middle turns on when the output voltage is within ± 100 mV. When the output voltage exceeds ± 10.05 V, the LED at the over-voltage side blinks.
(3)	Digital monitor (Four digit 1/2)	This monitor digitally displays the output voltage of OUTPUT 2 [5]. When OUTPUT2 level adjustment volume (18) is turned clockwise, [10.000] is indicated in response to an output of 10 V. In combination with (18), 2 kN can be displayed as [2.000] when the transducer converting 2 kN to 10 V is used. For decimal point shift, refer to page 3-9.

Table 2-1 Front Panel: Names and Functions (1)

Number	Name	Function
(4)	Bridge check /Cable length compensation /Auto-balance knob (BAL) * See pages 3-5 to 3-8 for bridge check and cable length compensation	<p>Pressing the knob performs bridge check and cable length compensation, enabling automatic balancing of resistors and capacitance. For details, see page 2-6 Indication upon Balancing.</p> <p>The result of bridge check is indicated on digital monitor (3). If there is neither disconnection nor short, the indication of Good is made, thereby making cable length compensation (dropout rate indication) and auto-balancing. If there is a disconnection or short, the problematic location is repeatedly indicated. After confirming the location, make repair. For more information on bridge check function, see pages 3-5 and 3-6.</p> <p>The capacitance balance is always offset. Whenever this button is pressed, the resistance balance is automatically kept accordingly.</p> <p>Note: When the high-pass filter is used (High-pass filter LED (15)lightning), even balancing is not performed, indication of good balance (OV) is made. Therefore, do not forget to perform balancing. When the high-pass filter is turned on, a frequency element of 0.5 Hz or lower including DC is deleted, which is the state of the offset voltage cancellation.</p>
	Resistance balance fine tuning (R-FINE)	Turning this knob clockwise moves the output to the positive side, while turning it counter-clockwise moves the output to the negative side.
(5)	Keylock switch (KEY LOCK)	On/Off switching for keylock can be made by pressing this knob for one second or longer. While in the lock state, keylock LED (6) turns on. In this state, BAL (4), measuring range selection (8), measuring range fine tuning (9), calibration value setting (12) and filter setting (16) cannot be used. Pressing this knob for one second or longer cancels the lock; keylock LED (6) also turns off.
(6)	Keylock LED	This LED indicates whether keylock is effective or not, in that light-up for lock and light-out for unlock..
(7)	Bridge power voltage LED (BV (V))	This LED indicates the bridge power voltage (0.5 V or 2 V). To select, use bridge power voltage selection switch 3 on the rear panel.

Table 2-1 Front Panel: Names and Functions (2)

Number	Name	Function
(8)	Measuring range selection knob (RANGE)	This knob is used to select the measuring range. Turning this knob clockwise narrows the measuring range (i.e. increasing the sensitivity). See page 3-4 for measuring range. In this case, fine tuning is not made. [Fine tuning LED (10) turns off.]
(9)	Measuring range fine tuning knob (FINE)	Fine tuning is made with the knob.. Turning the knob clockwise narrows measuring range (i.e. increasing sensitivity) and widens the range (i.e. decreasing sensitivity). As measuring range fine tuning knob (9) and measuring range selection functions together, the range automatically shift when signals exceeds the measuring range. See measuring range LED (11). Fine tuning LED (10) turns off upon range shift.
	Speed selection (SLOW/FAST)	Pressing this knob allows the fine tuning speed for measurement range to switch between high speed and low speed. Also, resistance balance fine tuning (4) is switched between high speed and low speed.
(10)	Fine tuning LED	This LED comes on while fine tuning is made.
(11)	Measuring range LED	This LED displays measuring range from an output of 10V/200,000 $\mu\epsilon$ to 10V/200 $\mu\epsilon$ (for AS1603, AS1803R) ($\mu\epsilon=10^{-6}$ strain). For the measuring range for AS1703, refer to page 3-3 Measuring Range.
(12)	Calibration value setup knob (CAL($\mu\epsilon$)) $\mu\epsilon=10^{-6}$ strain 	Indicated value is calculated value based on input. The value can be set from 1 $\mu\epsilon$ to 9999 $\mu\epsilon$ by a step of 1 $\mu\epsilon$. Pressing the knob changes the digit for calibration value LED (13) and turning the knob changes values. For further information, see page 2-5 How to Set Calibration Value. The value the equivalent voltage value based on a gauge factor of 2.0 and the one gauge configuration (1mV/V=2000 $\mu\epsilon$).
(13)	Calibration value LED	The LED displays calibration value and setting status (digit blinking).
(14)	Calibration value application switch	This switch is used to input the value that is set by calibration value setting knob (12). Pushing toward right inputs a plus value (tension) and pushing toward left inputs a minus value (compression). As a calibration value is superimposed with the input signal to generate the output voltage, return the position to OFF (middle) after inputting the calibration value.

Table 2-1 Front Panel: Names and Functions (3)

Number	Name	Function
(15)	High-pass filter LED	This LED turns on when the high-pass filter is used.
(16)	ON./OFF for high-pass filter (FILTER)	Pressing the knob allows the high-pass filter to switch between ON and OFF. High-pass filter LED (15) turns on for ON and it turns off for OFF. Filter type: 2-pole Butterworth filter Cut-off frequency: 0.5 Hz
	Low pass filter setting knob (FILTER)	This knob is used to set the low-pass filter. Turning the knob allows the filter to be set to OFF (= W/B) or cut-off frequency. The setting information is displayed on low-pass filter LED (17). Filter type: 4-pole Butterworth filter Cut-off frequencies: 10, 30, 100, 300, 500 Hz, W/B (for AS1603, AS1803R) Cut-off frequencies: 10, 30, 100, 500 Hz, 3 kHz, W/B (for AS1703)
(17)	Low-pass filter LED	This LED indicates the cut-off frequency for the low-pass filter. W/B (wideband) signifies OFF for the low-pass filter.
(18)	OUTPUT2 level control volume	The output voltage for OUTPUT2 <input type="text" value="5"/> can be controlled from the rating 10 V to 1 V. Control the voltage with the attached screw driver. The output value is indicated on the digital monitor (3). As decimal point shifting is possible through the dip switch on the bottom face of the amplifier unit, digital monitor (3) can be used for an indicator. For how to shift the decimal point, refer to page 3-9.
(19)	Power switch (POWER)	Pressing this switch supply the power to the amplifier unit. The power is turned off by pressing this button again.

Table 2-1 Front Panel: Names and Functions (4)

2.2 How to Set Calibration Value (CAL)

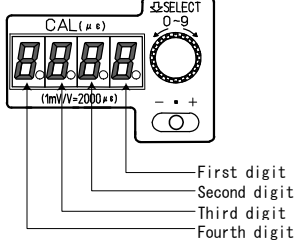
The indicated value is calculated value based on input. The value can be set from $1\mu\epsilon$ to $9999\mu\epsilon$ by a step of $1\mu\epsilon$ ($=10^{-6}$). Values should be set for each digit (Figure 2-3). Pressing calibration value setting knob (12) (Figure 2-4) turns on the fourth digit of calibration value LED (13). Turning the switch changes the value on (13). Even the indication is blinking, the setting is being made. Press the knob when your target value is indicated. In this case, blinking of (13) turns to lightning (value fixed), and then the third digit starts blinking. Repeat this step up to the first digit. After the first digit turns on and then all digits turns on, calibration value setting completes. To change the calibration value, repeat the steps above. The value is based on the equivalent value for gauge factor 2.00 and one gauge configuration. For strain gauge-type transducer, set and calculate the value based on $1\text{mV/V}=2000\mu\epsilon$.

■ Calibration value setting

For strain input ($\mu\epsilon$)										
Calibration value (CAL) setting range	Forth Digit		Third Digit		Second Digit		First Digit			
1 to 9999	0	1	2	3	4	5	6	7	8	9

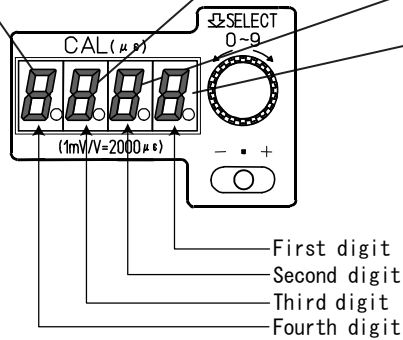

Fig.2-3 Calibration value (CAL)

E.g. To convert Calibration value (CAL) from $2000\mu\epsilon$ to $5000\mu\epsilon$

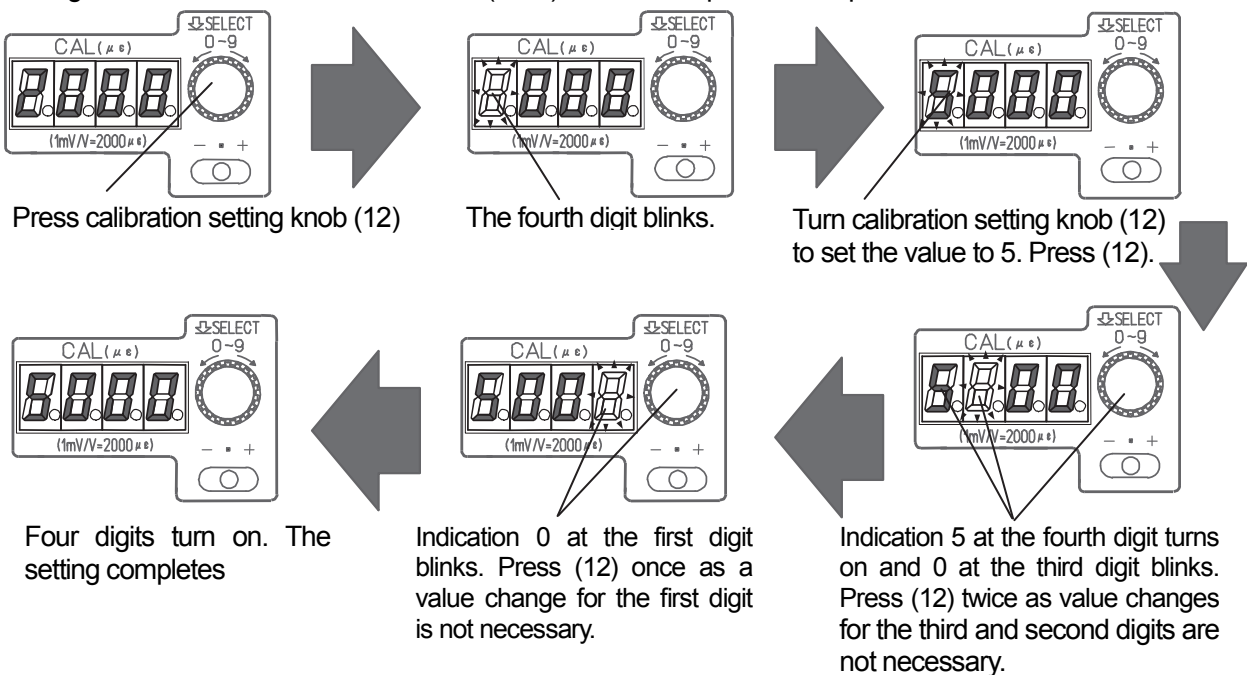
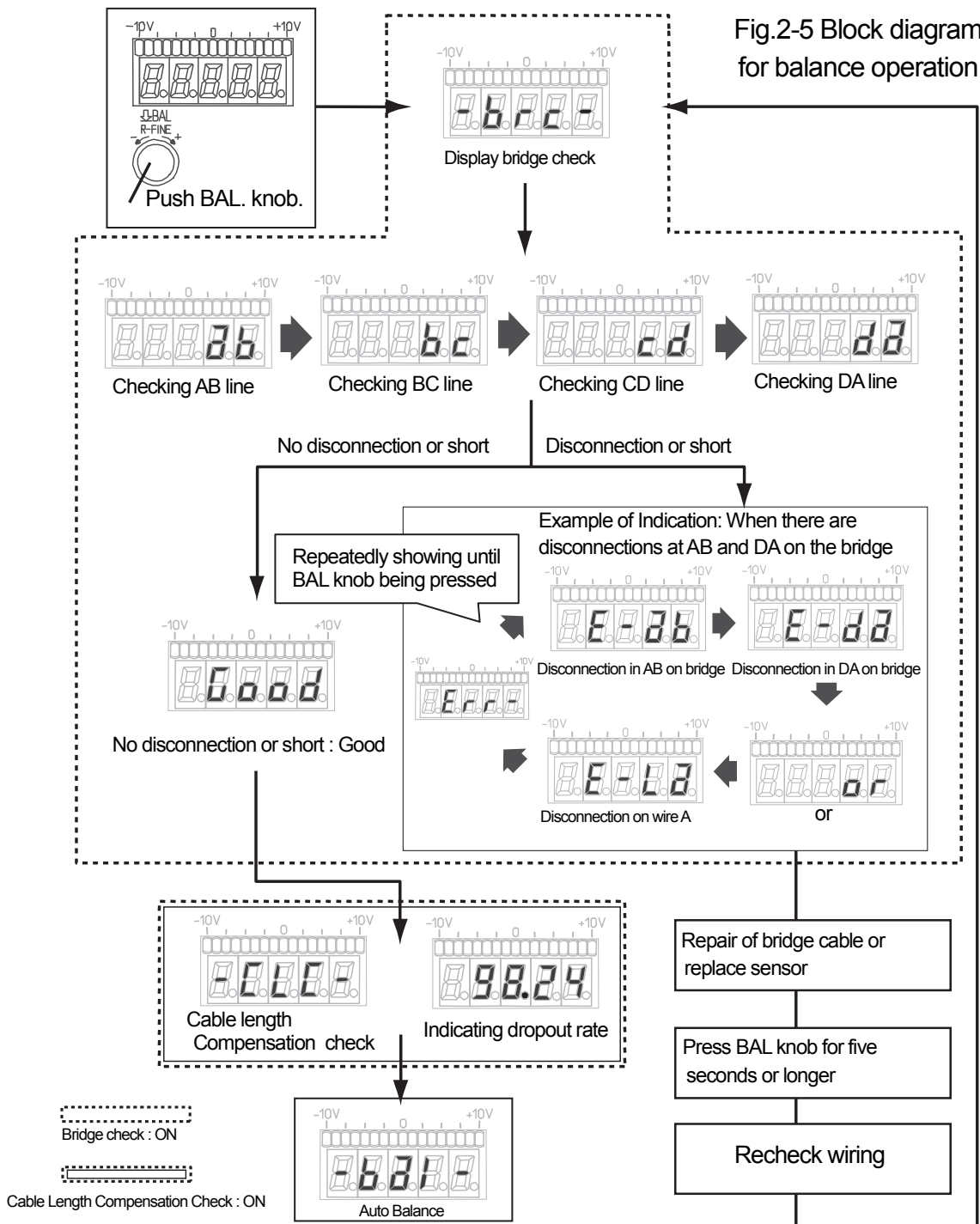

Fig.2-4

2.3 Indication upon Balancing

Pressing BAL knob (4) executes bridge check and cable length compensation, thus automatically realizing both resistance balancing and capacitance balancing. While the bridge check and cable length compensation functions are effective (ON), the following indications appear. If there is bridge cable disconnection or short, the problematic location is indicated repeatedly on digital monitor (3). The indication continues until the BAL knob is pressed for five seconds or longer or the power of amplifier is turned off. Make repair following the indication. When bridge check is not effective (OFF), the portions enclosed by broken line are omitted, executing auto-balancing. For how to set these functions to ON or OFF, refer to page 3-9 How to Switch Special Function Setting.



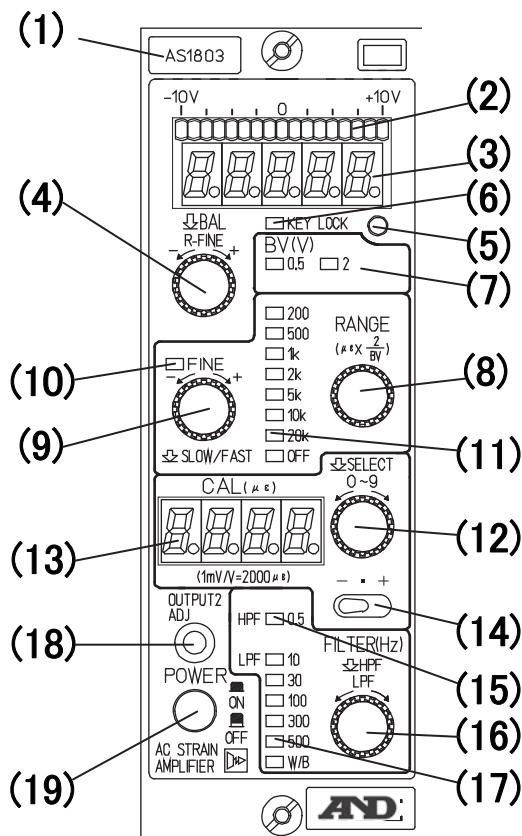

Fig.2-1 Face of panel

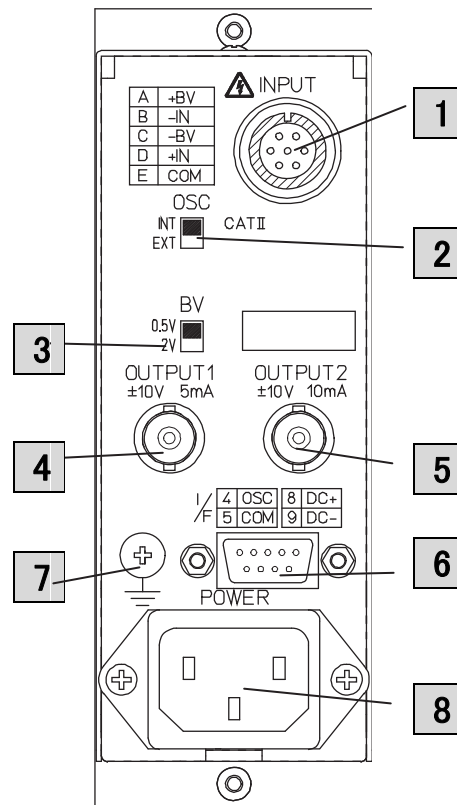

Fig.2-2 Back face

2.4: Names and Functions of parts on Rear Panel (See Table 2-2)

Number	Name	Function
1	Input connector (INPUT)	The bridge box or a transducer is connected.
2	Synchronization selection switch (OSC)	This switch is use to set the settings for bridge power voltage circuit included in the amplifier. INT: Set to be the master, using internal circuit EXT: Set to be a slave, allowing this unit to synchronize with the master's bridge power voltage circuit When the amplifier is used in a stand-alone, always set the switch to INT. When a case is used, the synchronous signal is supplied through in-case wiring. The amplifier unit whose setting is set to be INT is the master; therefore, other units should be set to EXT. For more details, see page 3-10 Synchronization among Units.
3	Bridge power voltage selection switch (BV)	Selection of power voltage applied to the bridge can be switched (0.5 V or 2.0 V).

Table 2-2 Rear Panel: Names and Functions(1)

Number	Name	Function									
4	Output connector 1 (OUTPUT1)	The output voltage and current are ± 10 V and ± 5 mA, respectively. This connector can be connected to a recorder (e.g. thermal-dot recorder or data acquisition devices) or A/D converter, which accept voltage signals									
5	Output connector 2 (OUTPUT2)	The output voltage and current are ± 10 V and ± 10 mA, respectively. The output level can be controlled from 10 V to 1 V with OUTPUT2 level adjustment volume (18) on the front panel. Note: If output of current from 4 to 20 mA is required, modification from the voltage output to the current output is available with extra costs. For details, contact with our sales representative.									
6	Interface connector (I/F)	This connector is used to connect an amplifier unit and case electrically. The pin layout is shown as follows. Other than DC power voltage supply, it is possible to perform keylock, auto-balancing, calibration value application, and synchronous signal output. A connection cable is available separately.  <p style="text-align: center;">Amplifier, Interface connector (from rear side)</p> <table border="1" style="margin-left: auto; margin-right: auto;"> <tbody> <tr> <td>(1) +CAL</td> <td>(2) -CAL</td> <td>(3) BAL</td> </tr> <tr> <td>(4) OSC</td> <td>(5) GND</td> <td>(6) KEYLOCK</td> </tr> <tr> <td>(7) GND</td> <td>(8) DC+</td> <td>(9) DC-</td> </tr> </tbody> </table>	(1) +CAL	(2) -CAL	(3) BAL	(4) OSC	(5) GND	(6) KEYLOCK	(7) GND	(8) DC+	(9) DC-
(1) +CAL	(2) -CAL	(3) BAL									
(4) OSC	(5) GND	(6) KEYLOCK									
(7) GND	(8) DC+	(9) DC-									
7	Protective grounding terminal	If 3-pin power cord cannot be used for grounding, use this terminal for grounding.									
8	Power supply connector	This is the connector to be connected to the AC power cable. The AC power supply block of the amplifier unit have a withstand voltage of 1.5 kVAC/minute against input, output, and case. Note: When using a power supply of 100VAC, use AC power supply cord 47326. When using 110VAC or higher, use optional AC power cord 200V (0311-5112). When using 180 to 264 VAC, also use optional AC power cord 200V (0311-5112).									

Table 2-2 Rear Panel: Names and Functions(2)

3 . BEFORE MEASURING

3.1 Cable Connections

3.1.1 Input Cable Connections

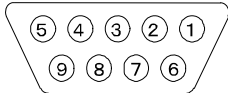
- (1) Paste a strain gauge to the location where measurement is made.
- (2) Connect the strain gauge to the bridge box.
- (3) Connect the bridge box or a transducer to the input connector **1** on the rear panel. For connection information, see Cautions before Measuring on page 4-1. Since the AS1000 series automatically adjusts the voltage drop generated between the bridge and the AS1000 series amplifier through the cable length compensation function, high-accuracy measurement is possible. For more information on this adjustment function, see page 3-7.
- (4) If you must measure large strains or wish to reduce the voltage going entering into the transducer, you can change the bridge voltage to 0.5 V. Set the bridge voltage to 0.5 V using bridge voltage selection switch **3** on the rear panel.

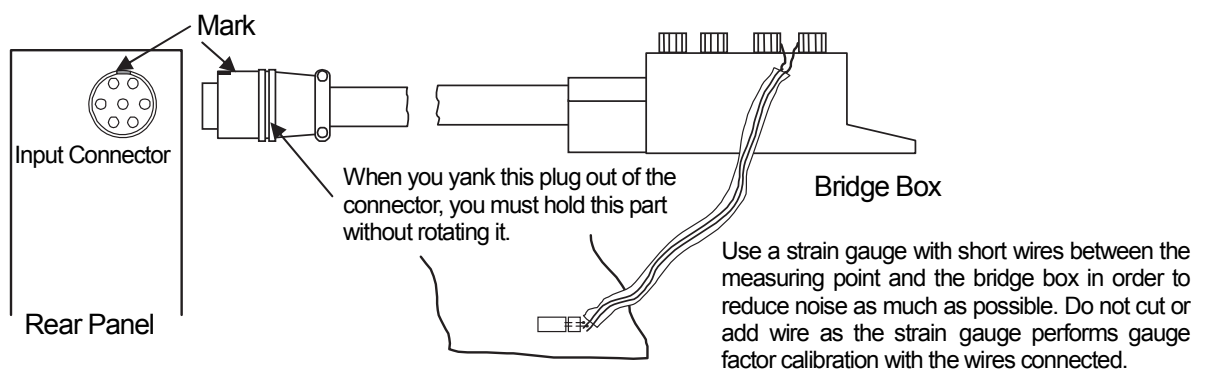

Fig.3-1 Connection with bridge box and so on

3.1.2 Power Supply Cable and Output Cable Connections (See Fig. 3-2)

- (1) Use the power supply cable for 100 VAC (Model 0311-5112 for 110 VAC or higher), 200 VAC, or 12 VDC depending on the voltage.
- (2) Connect the output cable appropriate to the recorder to be used.
- (3) For more information, refer to Connection between Output and Load on page 4-8.
- (4) The chassis of this amplifier is connected to the output common lead.

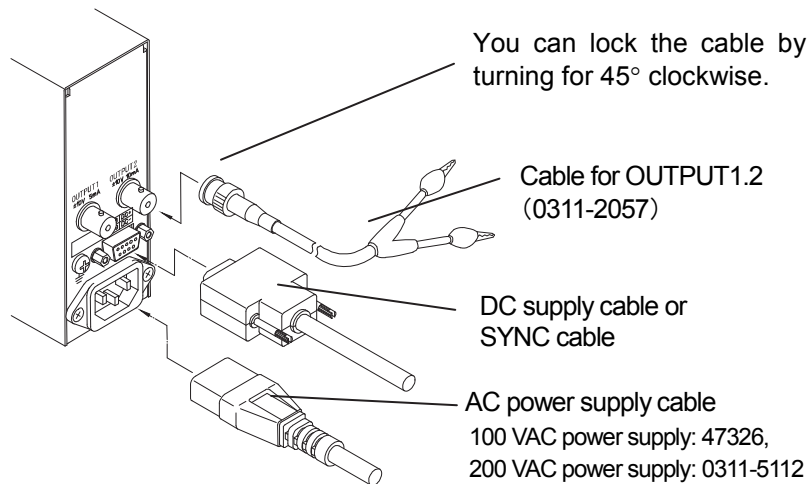

Fig.3-2、 Connection of power supply cable and output cable

3.2 Operation before Measuring

3.2.1 Standalone Operation

- (1) Set the calibration value application switch (14) (+ • -) to the • (OFF) position.
- (2) Pressing power switch (19) (POWER) supplies power to the amplifier.
- (3) Set the measuring range to OFF (Measuring Range LED (11)) using measuring range selection knob (8) (RANGE).
- (4) Setting the measuring range to OFF using measuring range selection knob (8) illuminates the green LED in the middle of level meter (2). Activate for about 10 minutes.
- (5) For correct strain measurement, you must conduct initial balancing for the bridge circuit. Tune to your target measuring range using measuring range selection knob (8) and adjust the output to zero while no load is being applied.
- (6) Bridge check, cable length compensation, and automatic balancing
Turn measuring range selection knob (8) clockwise up to your target measuring range, and then narrow the measuring range (i.e. increasing sensitivity). In this case, the indication of measuring range LED (11) changes from OFF to other values, in that the value changes toward 200. Pressing the BAL knob (4) performs the bridge check, cable length compensation (indication of the rate of damping), and auto-balancing in this order. For more information, see Indication upon Execution of BAL on page 2-6. (These functions are available when the dip switches for the bridge check and cable length compensation are set to ON.)

When there is neither cable disconnection nor a short, and indication of Good is indicated on

the digital monitor (3), and then the cable length compensation (indication of the rate of damping) and auto-balancing are performed. If there is a cable disconnection or short, the examination results are indicated on the digital monitor (3) repeatedly. The contents to be indicated are listed on the pages from 3-4 to 3-5. Following the indicated results (page 3-5), repair the cable or bridge. After the repair, press BAL again for at least five seconds to check for failures.

The cable length compensation automatically calculates the voltage drop occurring in the cable connecting between the AS amplifier and measurement point (bridge), saving this calculation data into the internal memory. The power supply to the bridge is provided after this adjustment. As a result, high-accuracy strain measurement is available without considering the conductor resistance generated by the cable.

After the cable length compensation is made, the initial balance is made, and then the green LED in the middle illuminates. For further fine-tuning, turn the BAL knob (4) clockwise or anti-clockwise. The adjustment range is an output of ± 1 V.

* The cable length compensation data is stored in the internal memory until the BAL switch is pressed, even if the power switch (19) is turned on or off. The wire length function is set to off or non-adjustment by the dip switch on the bottom face of the AS amplifier.

* For more information on bridge check function and cable length compensation, see the pages from 3-5 to 3-8.

- (7) In response to the magnitude of the strains anticipated, apply a calibration value using the calibration setting knob (12) first, and then start measuring.

The measuring range can be checked after applying a calibration value using the calibration value application switch (14). The measuring ranges for AS amplifiers are described in Measuring Ranges for AS1603, AS1703, AS1803R on page 3-4.

3.2.2 Measurement Range

Measurement Range LED⑩	Fine adjustment Knob⑨	Range × 10 ⁻⁶ Strain (± 10V Full Scale)	
		BV=0.5V	BV=2V
200	1X to 2.5X Continuous Variable	±800~ ±2,000	±200~ ±500
500	1X to 2X Continuous Variable	±2,000~ ±4,000	±500~ ±1,000
1K	1X to 2X Continuous Variable	±4,000~ ±8,000	±1,000~ ±2,000
2K	1X to 2.5X Continuous Variable	±8,000~ ±20,000	±2,000~ ±5,000
5k	1X to 2X Continuous Variable	±20,000~ ±40,000	±5,000~ ±10,000
10k	1X to 2X Continuous Variable	±40,000~ ±80,000	±10,000~ ±20,000
20K	1X to 2.5x Continuous Variable	±80,000~ ±200,000	±20,000~ ±50,000

Table3-1 Measurement Range of AS1603, AS1803R

Measurement Range LED⑩	Fine adjustment Knob⑨	Range × 10 ⁻⁶ Strain (± 10V Full Scale)	
		BV=0.5V	BV=2V
500	1X to 2X Continuous Variable	±2,000~ ±4,000	±500~ ±1,000
1k	1X to 2X Continuous Variable	±4,000~ ±8,000	±1,000~ ±2,000
2K	1X to 2.5X Continuous Variable	±8,000~ ±20,000	±2,000~ ±5,000
5K	1X to 2X Continuous Variable	±20,000~ ±40,000	±5,000~ ±10,000
10k	1X to 2X Continuous Variable	±40,000~ ±80,000	±10,000~ ±20,000
20k	1X to 2.5X Continuous Variable	±80,000~ ±200,000	±20,000~ ±50,000
50K	1X to 2.5X Continuous Variable	±200,000~ ±500,000	±50,000~ ±125,000

Table3-2 Measurement Range of AS1703

Sensitivity fine adjusting knob⑨ has automatic range switching function.

3.3 Bridge Check Function

3.3.1 Overview

The bridge check function of the AS amplifiers can detect a bridge cable disconnection, short, or cable disconnection. Since disconnected portions can easily be found, testing personnel can reduce the measurement preparation time or prepare countermeasures against cable disconnections. The bridge check function can be set to on or off using the dip switch on the bottom face of the AS amplifier.

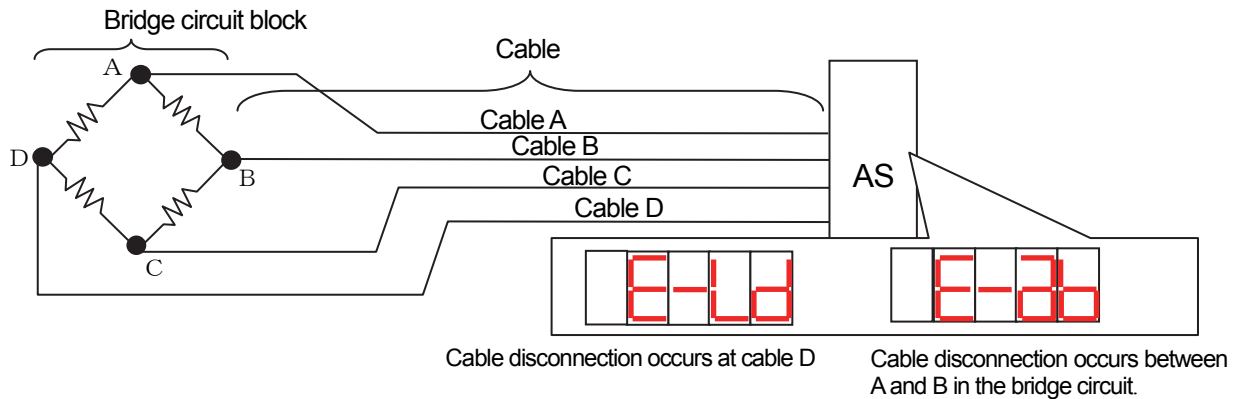

Fig.3-3 Block diagram for bridge check

When no failure is found after the bridge check, the indication Good is displayed on the digital monitor. If a failure is found, the failure information is repeatedly displayed on the digital monitor (3). The indication does not disappear until the BAL knob is pressed or the amplifier unit power supply is turned off. For error contents, refer to page 3-5. After confirming the cause of failure, take measures to repair the failure. Following repairs, press the BAL knob for longer than five seconds for disconnection checking. If there is no problem, Good is indicated.

If disconnection or a short is detected, there is always an error indication. However, the failure location may not be found depending on the number of disconnections or the disconnection conditions on the cable or at the bridge, or both.

When the bridge check is turned off, switch the dip switches on the bottom face of the amplifier according to How to Switch Special Function Setting on page 3-9.

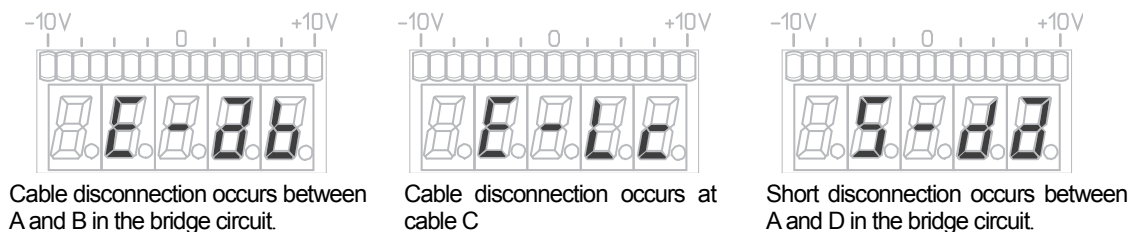

Fig. 3-4 Example of error indication

3.3.2 Error Indication List upon Cable Disconnection and Short

Error indication in the case of disconnection

Disconnection on bridge circuit				Disconnection on cable				INDICATION (Digital Monitor ^③)
A-B	B-C	C-D	D-A	A	B	C	D	
○	○	○	○	○	○	○	○	Good
x	○	○	○	○	○	○	○	E-ab
○	x	○	○	○	○	○	○	E-bc
○	○	x	○	○	○	○	○	E-cd
○	○	○	x	○	○	○	○	E-da
x	x	○	○	○	○	○	○	E-ab E-bc or E-Lb
○	○	○	○	○	x	○	○	E-bc E-cd or E-Lc
○	x	x	○	○	○	○	○	E-bc E-cd or E-Lc
○	○	○	x	x	○	○	○	E-cd E-da or E-Ld
○	○	○	○	○	○	○	x	E-cd E-da or E-Ld
x	○	○	x	○	○	○	○	E-ab E-da or E-La
○	○	○	○	x	○	○	○	E-ab E-da or E-La
○	x	○	x	○	○	○	○	E-bc E-da
x	○	x	○	○	○	○	○	E-ab E-cd
x	x	x	○	○	○	○	○	E-ab E-bc E-cd or E-Lb E-Lc
○	○	○	○	○	x	x	○	E-ab E-bc E-cd or E-Lb E-Lc
x	x	○	x	○	○	○	○	E-ab E-bc E-da or E-La E-Lb
○	○	○	○	x	x	○	○	E-ab E-bc E-da or E-La E-Lb
x	○	x	x	○	○	○	○	E-ab E-cd E-da or E-La E-Ld
○	○	○	○	x	○	○	x	E-ab E-cd E-da or E-La E-Ld
○	x	x	x	○	○	○	○	E-bc E-cd E-da or E-Lc E-Ld
○	○	○	○	○	○	x	x	OPEn
○	○	○	○	x	○	x	○	
○	○	○	○	x	x	x	○	
○	○	○	○	x	x	○	x	
○	○	○	○	x	○	x	x	
○	○	○	○	○	x	x	x	
○	○	○	○	x	x	x	x	
x	x	x	x	○	○	○	○	

Error Indication in the case of short

Disconnection on bridge circuit				Disconnection on cable				INDICATION (Digital Monitor ^③)
A-B	B-C	C-D	D-A	A	B	C	D	
○	○	○	○	○	○	○	○	Good
x	○	○	○	○	○	○	○	S-ab
○	x	○	○	○	○	○	○	S-bc
○	○	x	○	○	○	○	○	S-cd
○	○	○	x	○	○	○	○	S-da
x	x	○	○	○	○	○	○	S-ab S-bc
○	x	x	○	○	○	○	○	S-bc S-cd
○	○	x	x	○	○	○	○	S-cd S-da
x	○	○	x	○	○	○	○	S-ab S-da
x	○	x	○	○	○	○	○	S-ab S-cd
○	x	○	x	○	○	○	○	S-bc S-da
x	x	x	○	○	○	○	○	S-ab S-bc S-cd S-da
x	x	○	x	○	○	○	○	
x	○	x	x	○	○	○	○	
○	x	x	x	○	○	○	○	
x	x	x	x	○	○	○	○	

Table3-3 Error indication list for cable disconnection and short

3.4 Cable Length Compensation Function

If the length of the cable connecting between the bridge and amplifier is long, the bridge resistance is lower due to the conductor resistance of the cable. For the rate of the bridge voltage drop, refer to table 3-4 below. Before this function is employed, testing personnel made remote sensing through a 6-core cable or adjustment through values for the cable length or wire diameter.

The AS series employs a unique automatic compensation circuit in lieu of the conventional techniques, thereby enabling supplying the bridge power that reflects conductor resistance. Since high-accuracy strain measurement is possible, there are reductions in measurement time and measurement time.

On/off for cable length compensation can be switched using the dip switch on the bottom face of the amplifier. See page 3-9 for more details.

Bridge Resistance	Distance between amplifier and bridge box (m)			
	20m	50m	100m	200m
120Ω	-2.7	-3.0	-5.8	-11.0
350Ω	-0.9	-1.1	-2.1	-4.1
500Ω	-0.6	-0.7	-1.5	-2.9
1000Ω	-0.3	-0.4	-0.7	-1.5

Table3-4 Bridge voltage drop rate (%) (0.5mm² Wire, 20°C)

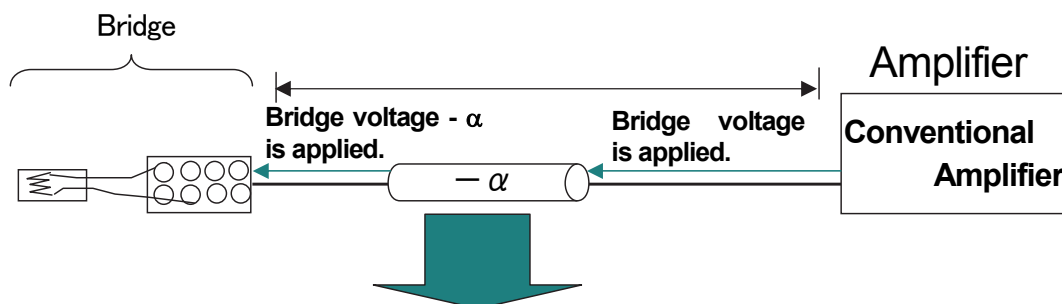

- 1) Automatically calculating voltage drop of the bridge voltage due to cable conductor resistance.
- 2) Applying the bridge voltage reflecting the voltage drop

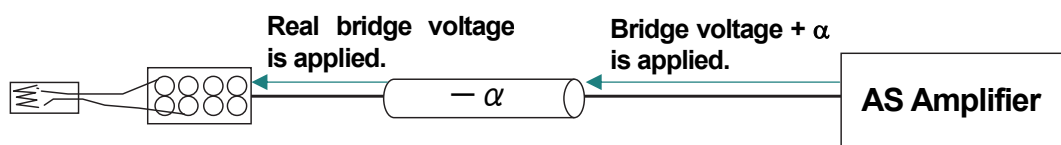

Length: 300m, Core wire: 0.5 mm², using our optional extension cable

Fig.3-5 Schematic diagram of cable length compensation Function

⚠ CAUTION

The AS Series amplifiers are provided with the cable length compensation function that corrects the voltage drop of excitation voltage supplied from the amplifier if the wire length between the amplifier and bridge circuit for strain measurement.

This functionality is based on the assumption that the transducer or bridge box is configured by the Wheatstone bridge circuit. Therefore, the cable length compensation function does not function if a calibration value generator that does not include the Wheatstone bridge circuit.

Moreover, the cable length compensation function may not correctly function for transducers that include a resistor for output adjustment. The reason is the amplifier regards the resistance of the resistor for output adjustment as the resistance of wire, thereby correcting the voltage drop. As a result, the voltage applied to the transducer may increase by a maximum of 130% compared to the normal voltage, which causes the transducer to output larger values. Be careful when using transducers.

Model	Resistor	Model	Resistor	Model	Resistor	Model	Resistor
9E01-L1	Provided	9E01-L21	Provided	9E02-P2	Provided	9E08-D1A	Provided
9E01-L2	Not provided	9E01-L22	Provided	9E02-P3	Not provided	9E08-D2	Provided
9E01-L3	Provided	9E01-L23	Provided	9E02-P4	Provided	9E08-D3	Provided
9E01-L4	Provided	9E01-L23W	Provided	9E02-P5	Not provided	9E08-D4	Provided
9E01-L5	Provided	9E01-L23H	Not provided	9E02-P6	Not provided	9E08-D5	Provided
9E01-L8	Provided	9E01-L31	Provided	9E02-P6G	Not provided	9E08-D6	Not provided
9E01-L9	Provided	9E01-L33	Provided	9E02-P7	Not provided	9E08-D7	Not provided
9E01-L11	Provided	9E01-L35	Provided	9E02-P11	Provided	9E05-B1	Provided
9E01-L14	Provided	9E01-L36	Provided	9E02-P13	Provided	9E05-T1	Provided
9E01-L15	Provided	9E01-L41	Not provided	9E02-P14	Not provided	9E06-S1	Not provided
9E01-L18	Provided	9E01-L42	Not provided	9E02-P15	Not provided	9E06-S2	Not provided
9E01-L18W	Provided	9E01-L43	Not provided	9E02-P16	Not provided	9E07-A1	Not provided
9E01-L19	Provided	9E01-L44	Not provided	9E02-P17	Not provided	9E07-A3	Not provided
9E01-L19W	Provided	9E01-L45	Not provided				

Table3-5 Resistor for output adjustment in 9E Series transducers

⚠ CAUTION

Careful Note for using type-AS1703 AC strain amplifier

AS1703 is AC strain amplifier that carries 25kHz carrier. It can perform higher frequency measurement possible than these AS1603, AS1803R, which carries 5kHz carrier. If the distance between this product and a bridge circuit for measurement is too long, by using a cable length compensation function that adjust the drop of excitation voltage from AS1703 and accurate measurement can be performed. However, 25kHz excitation tends to be affected by cable length, transmission property and other unstable factors, the cable becomes longer, the more amplitude of the excitation changes that resulted accuracy loss. When with AS1703, as our family products extension cable 47230 or extension cable 47231 is in use, the distance between the AS1703 and any bridge cable for the measurement should be less 50m.

3.5 How to Switch Special Function Setting

By switching dip switches on the bottom face of the AS amplifier, settings for special functions can be made.

- ON/OFF for cable length compensation
- ON/OFF for bridge check function
- Decimal point shift for digital monitor (3)

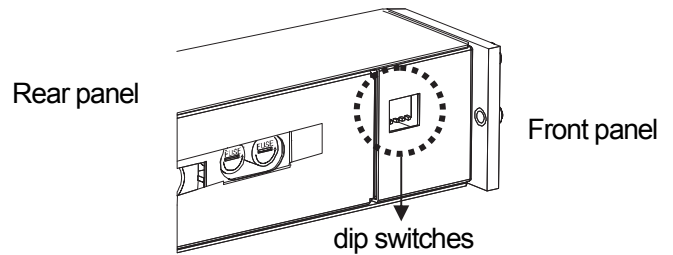

Fig3-6 Position of dip switch

Dip switch	Function	Description
	Factory-set (Factory-set settings)	Cable length compensation function: (Switch 1 is Off.) Bridge check function: ON (Switch 2 is On.) Decimal point of digital monitor (3), displaying decimal point at the fourth place: 10.000 (Switches 3 and 4 are On.)
	Cable length compensation function (Switch 1 changeover)	Cable length compensation function: OFF (Switch 1 up: Off) Cable length compensation function: ON (Switch 1 down: On)
	Bridge check function (Switch 2 changeover)	Bridge check function: OFF (Switch 2 up: Off) Bridge check function: ON (Switch 1 down: On)
	Decimal point indication (Setup through the combinations of switches 3 and 4)	Displaying the decimal point of digital monitor (3) at the third place: 100.00
	Decimal point indication (Setup through the combinations of switches 3 and 4)	Displaying the decimal point of digital monitor (3) at the second place: 100.00
	Multipoint indication (Setup through the combinations of switches 3 and 4)	No indication of the decimal point on digital monitor (3): 10000

Table3-6

ON/OFF switching for dip switches is possible when the amplifier is turned on.

3.6 Case

3.6.1 Names of Case Elements

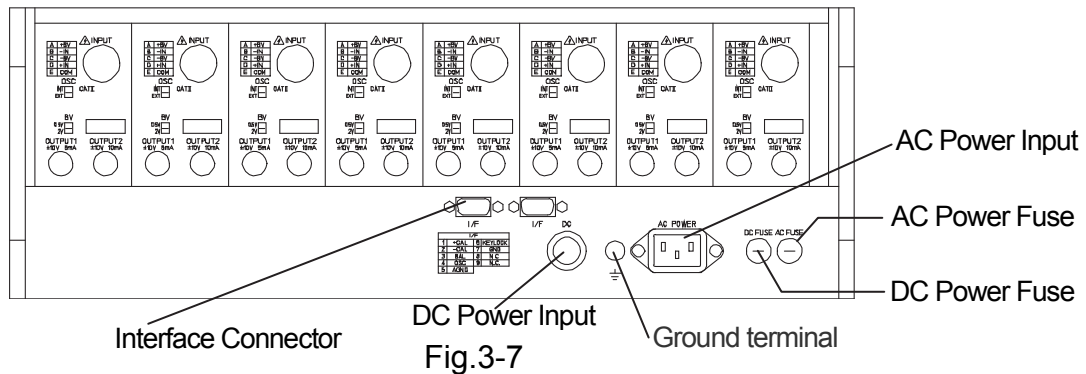

- Use standard AC power cord (47326) that is attached to the case as a standard for 100 VAC power supply.
- Use optional DC power cord (47229) for DC power supply.

3.6.2 How to Use Case

A) Power supply cable connection

When using a battery (12 VDC, or 10 to 30 VDC) for power supply with amplifier units being installed in a case, take into account the voltage drop caused by the DC power cord length and wire diameter. When using several channels or a long power supply cord, a voltage drop occurs. This voltage drop may cause the power supply voltage to be lower than the allowable power supply voltage of 10 V at DC power input connector.

For example, the DC power supply cord (47229) has a core area of 1.25 mm². If eight amplifiers are mounted, a current of 3.2 A (0.4 A x 8) flows, and a voltage drop of 0.5 V will occur if the cord is extended to 10 m. If a 10-m cable with 0.75 mm² is used, a voltage drop of 1.65 V will occur. For use under such conditions, the power supply should be provided with the voltage drop taken into account, or the wire diameter or cord length of the power cord should be modified.

B) Synchronization between units

When two or more amplifier units are installed in a case, unit synchronization is maintained by the internal wiring inside the case and synchronization signal. One amplifier should be set to be the master, and others should be set to be slaves. To set the unit to be the master, set synchronization switch **2** on the rear face panel to INT; to set to the slaves, set the switch to EXT. Note that only amplifier units that have the same bridge power frequency can be installed in a case. It is impossible to share a common case or synchronize between cases that have amplifiers installed with different bridge power frequencies. Take notice that the bridge power frequency of AS1603, AS1803R is 5 kHz and that of AS1703 is 25 kHz.

CAUTION

Do not set two or more units to INT. Otherwise correct measurement cannot be made, or this may cause a defect in amplifier units.

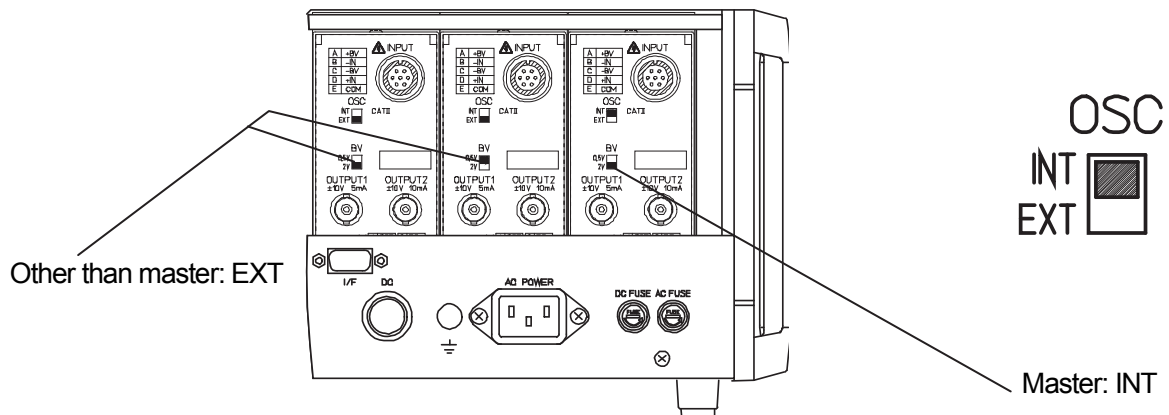

Fig.3-8 Rear Panel of Case

C) Synchronization between cases

When two more cases are used, synchronization between the cases is needed. As shown in Figure 3-8, it is possible to maintain synchronization by connecting the interface connectors on the rear face of the case using synchronization cable (AS16-402). After the cases are connected, one case should be set to INT using the synchronization selection switch **2**, and the other cases should be set to EXT. Note that only amplifier units with the same bridge power frequency can be installed in a case. It is impossible to share a common case or synchronize between cases that have amplifiers installed with different bridge power frequencies. Take notice that the bridge power frequency of AS1603, AS1803 and AS1803R is 5 kHz and that of AS1703 is 25 kHz.

CAUTION

Do not set two or more units to INT. Otherwise correct measurement cannot be made, or this may cause a defect in amplifier units.

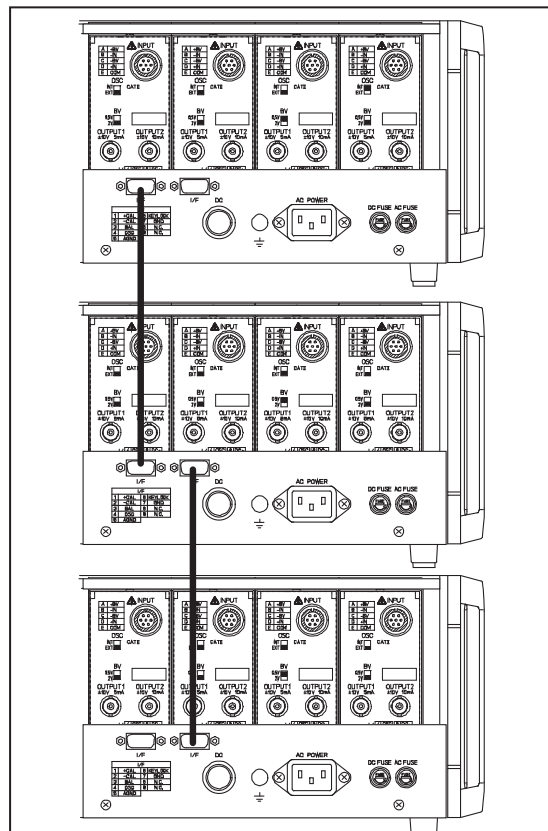

Fig.3-9 Connection of multiple cases

D) Synchronization of bridge power

The master unit (INT) provides slave units (EXT) with the synchronization signal for bridge power. Settings such as bridge voltage, calibration value, filter, measurement range, bridge check ON/OFF, and cable length compensation ON/OFF are effective in each amplifier unit.

E) Balancing for all units (1)

Hold down the switch for BAL for all units (1). You can execute the bridge check, cable length compensation, and auto-balancing for all units in a case. For a bridge check and cable length compensation, ON/OFF setting (selectable with dip switches) for each unit is also effective. Auto-balancing is made for all amplifier units. This function is available for all amplifier units installed in two or more cases, which are connected to each other with a synchronization cable. To perform auto-balancing for one unit, press the BAL knob (4) for that unit.

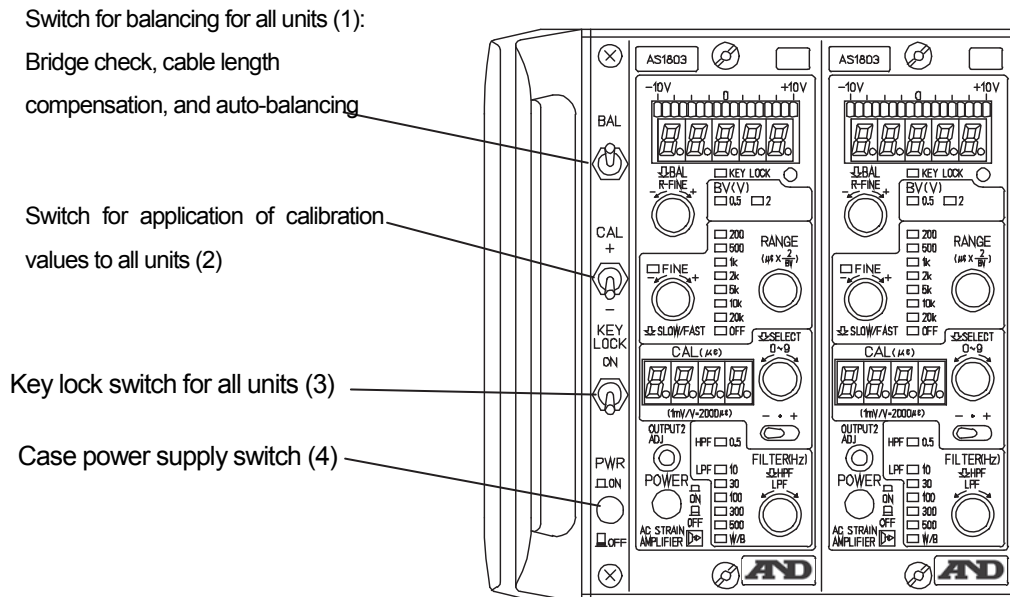

Fig.3-10 Front Panel of Case

F) Switch for application of calibration values to all units (2)

Hold down the switch to apply calibration value (2). A calibration value is set to all amplifier units. This switch has priority over the calibration value application switch (14) in each amplifier unit regardless of the position of the switch (+ • -). This function is available for all amplifier units installed in two or more cases, which are connected to each other with a synchronization cable. To apply a calibration value to only one unit, use the calibration value application switch (14) in each unit. Before doing so, confirm that the switch for applying the calibration value to all units is set to OFF.

G) All unit key locking switch (3)

Key locking is made for all amplifier units in a case by pushing up (ON) the key locking switch for all units (3). In this case, the all units key locking LED comes on. While key locking is effective, the BAL switch for all units (1) positioned in a case, BAL knob (4), measuring range selection knob (8), measuring range fine-tuning knob (9), calibration value selection knob (12), and filter selection (16) that are positioned on the front panel of each amplifier unit do not function. To cancel the key locking, hold down the key locking switch for all units (3). In this case, if key locking is set in each amplifier unit, the key locking status is maintained. This is applicable when two or more cases are being used.

H) Remote box

The same operations are available when a small control box like in Figure 3-10 is used. The BAL switch should include a locking mechanism in order to avoid erroneous operations. Use a momentary switch accordingly.

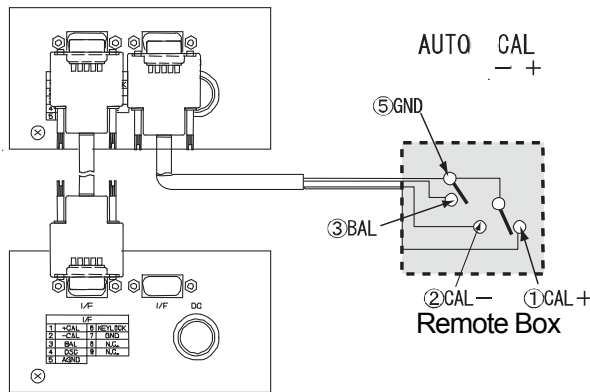
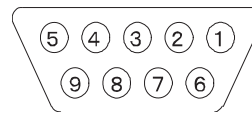

Fig.3-11 Schematic diagram of Remote



Case/Interface Connector Pin Alignment

① +CAL	② -CAL	③ BAL
④ OSC	⑤ GND	⑥ KEYLOCK
⑦ GND	⑦ N. C	⑧ N. C

Table3-7 Interface Connector at Rear Face of Case

3.6.3 Synchronization between Old-type and New-type Cases

Synchronization of the bridge power frequency between old-type cases (Bench-top housing cases: 7904, 7797, and 7798, and rack-mounting case: 7799) and new-type cases (Bench-top housing cases: AS16-104, AS16-105, and AS16-106, and rack-mounting case: AS16-107) is available using dedicated synchronization cable (AS16-403). Refer to Figure 3-11. Synchronization among amplifier units with different bridge power frequencies is not possible. For the bridge power frequency for old-type amplifiers, see Table

Case type	Bridge power frequency: 5 kHz	Bridge power frequency: 25 kHz
New	AS1603, AS1803R	AS1703
Old	Old-type amplifiers: AS1201, AS1202 AS1203, AS1503	Old-type amplifiers: AS1302

Table 3-8 Bridge Power Frequencies for Conventional Amplifiers

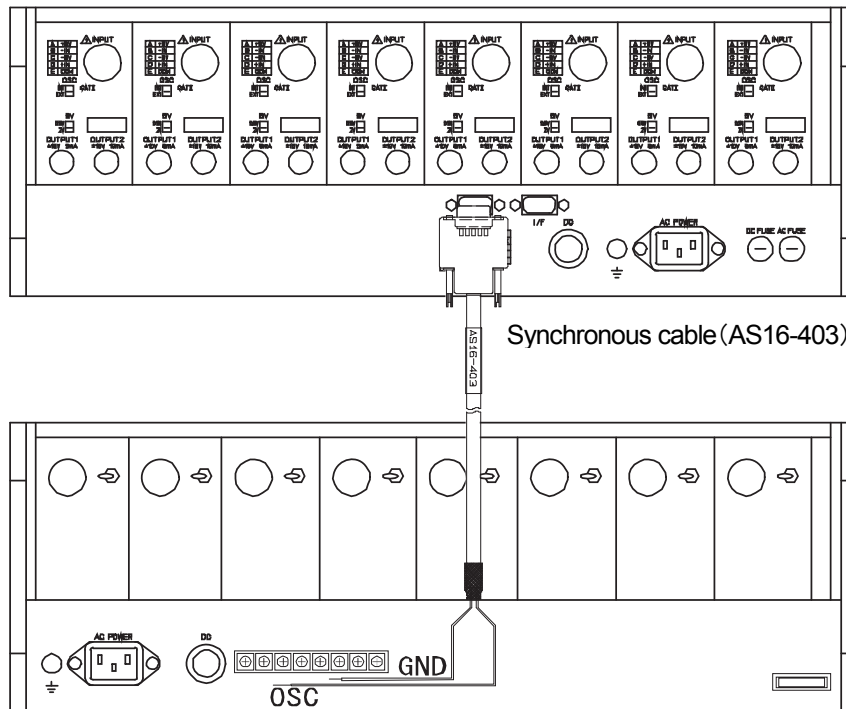

Fig.3-12 Connection between new case and conventional one

3.6.4 Heat Release for Case

A) Using standalone rack-mounting case



As a rack-mounting case does not have legs, avoid placing it on a desk or floor. Otherwise, heat cannot be released, resulting in damages to amplifiers. It should be properly mounted.

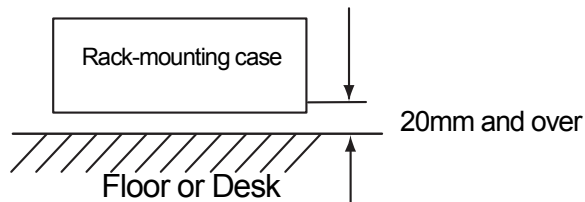

Fig.3-13 Setting of rack-mounting case

B) Using two or more rack-mounting cases

In this case, install fans following the criteria below because the temperature in the unit rises depending on the number of stacks in the rack, load, and ambient temperature.

Number of case	Number of fan unit under severe condition
1-3	1
3-6	2
6-9	3

Note: What are harsh environmental conditions?

- Power supply: 110 VAC (+10%)
- Output voltage and current: +10V, 10 mA
- Ambient temperature: +50°C
-

Table3-9 Relation between number of rack-mounting case and one of cooling fan

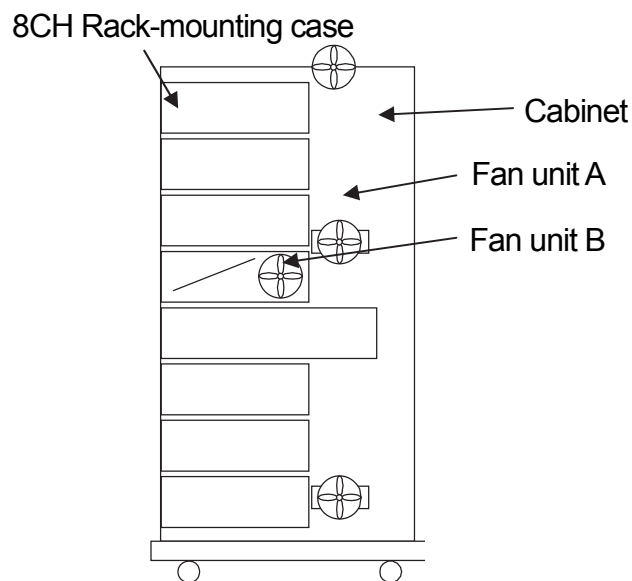

Fig.3-14 Disposition of fan

If fan unit A may prevent upward air flows (when the depth differs as shown with a slant), fan unit A should be mounted directly above this position. Through this fan layout, fan unit A ventilates, and fan unit B enhances natural convection. One fan unit B should be installed for every three cases. It should be mounted as close to a case as possible. When a user prepares fans, ask us in advance how to mount the fans.

4 . MEASUREMENT

4.1 Cautions before Measuring (Refer to Table 4.1)

Before starting measurement, check the following points:

Items	Cautions	Reasons
Installation environment for strain gauges and bridge box	The joints must be soldered, and the connectors must be properly connected.	Prevents poor connections, noise, and instability in operation.
	The insulation resistance of strain gauges must be equal to or greater than 60 MΩ.	Prevents instability in operation as well as noise from entering the equipment.
	Installing the bridge box and strain gauges in the presence of strong magnetic or electric fields must be avoided.	Prevents noise from entering the equipment.
	Install the bridge box and strain gauges in environments where there is as little moisture as possible and the ambient temperature is not high.	Prevents instability in operation.
	The leads that connect strain gauges to the bridge box should be as short as possible and should be shielded.	Prevents reduction in the gauge factor and deterioration in output linearity. Prevents noise from entering the equipment.
	The interconnecting cable, which connects the bridge box to the AS amplifier unit, should be as short as possible. (The AS amplifier automatically compensates for bridge voltage drops with its cable length compensation.)	Prevents a bridge voltage drop, which may result in an error between the signal and the internal calibrator.
Installation environment for dynamic strain amplifier system	The amplifier system must be used in environments where the ambient temperature ranges from -10 to +50°C and the ambient humidity ranges from 20 to 85% RH (with no condensation).	Prevents instability in operation.
	Install the amplifier system in environments where acceleration of mechanical vibrations is less than 3 G (3000 rpm, 0.6 mm _{P-P})	Prevents damage and noise from entering the equipment.
	Installing the amplifier system in the presence of strong magnetic or electric fields must be avoided.	Prevents noise from entering the equipment.
	The housing case must be properly grounded (when the system operates on AC power).	Prevents noise from entering the equipment.
Operation of dynamic strain amplifier system.	Select the bridge supply voltage in accordance with the strain gauge to be used.	Prevents measurement errors due to generation of heat in strain gauges.
	The connectors must be properly connected.	Prevents instability in operation and poor connections.
	Care must be taken not to smear the input connector with oil, dirt, or anything else.	Prevents instability in operation and poor connections.
	Verify that the power supply voltage is within the range of specifications. AC: 85 – 132 V, or 180 – 264 V DC: 10 – 30 V Check that the polarity of the battery is correct, especially when 12 VDC is used.	If the supply voltage is less than the lower limit, failures in operation may occur. If the supply voltage is higher than the specified upper limit, heat may be produced, which may result in damaging electronic components. If the polarity of the battery is not correct, the amplifier system will not operate. (However, the system and the battery will not be damaged though.)
Do not apply pressure to strain gauges when units are in the auto balancing mode.	Applying pressure to strain gauges in auto balancing mode causes the bridge to be unbalanced.	

Table4-1 Precautions before Measuring(1)

Operation of dynamic strain amplifier system.	Do not turn the measurement range selector control (8) or the measurement range fine adjustment control (9) during measurement. (Use the keylock function.)	Prevents changing the amplitude of a preset calibration value.
	Before using a low-pass filter, the operator should be familiar with its characteristics.	Prevents reducing amplitude and the occurrence of phase differences.
	Prevent short-circuit in the output cable.	The power supply may be disabled, and heat will be generated in the circuitry.
Countermeasures against noise	<p>The input, including the shield, of the unit (AS1603, AS1703, or AS1803R) is isolated from the output using a transformer.</p> <ol style="list-style-type: none"> 1. Use shielded wires as leads connecting strain gauges and connect the metal shields of the wires to terminal E on the bridge box. 2. Connect the ground terminal of the bridge box to terminal E and the base metal. 3. Ground the output common. <p>Performing all of or any of the above steps, 1, 2, and 3, may be effective for noise reduction.</p>	

Table4-1 Precautions before Measuring(2)

4.2 Input Connection

4.2.1 Examples of Strain Gauge Bridge Configurations

When incorporating one or more strain gauges into the four arms of a bridge, a quarter-, half- or full-bridge configuration can be used. These configurations can further be classified into same sign equivalent values, different sign equivalent values, and different sign constant proportional values according to the type of strain applied to the strain gauge(s). In addition, by effectively utilizing the characteristics of the bridge, measures can be taken to compensate for the effect of temperatures, eliminate errors, or increase the output.

This section describes examples of bridge configurations that are generally used. The following symbols are used:

- R: Resistance of fixed register (Ω)
- Rg: Resistance value of strain gauge (Ω)
- Rd: Resistance value of dummy gauge (Ω)
- r: Resistance value of lead wire (Ω)
- e: Output voltage from bridge (V)
- K: Gauge factor of strain gauge to be used (2.00)
- ϵ : Amount of strain applied ($\mu\text{m}/\text{m}$)
- E: Bridge excitation voltage (V)
- ν : Poisson's rate of an object to be measured

For information on how to cement strain gauges and on the characteristics of strain gauges, refer to the technical manuals provided by the strain gauge manufacturers. The wiring methods of the bridge boxes shown in Table 4 are applied where bridge box 5370 is used.

Circuit	Bridge Configuration	Examples	Bridge Box Wiring Method	Remarks
	One-gauge configuration			<ul style="list-style-type: none"> -Suited for where simple tension, compression, or bending force is applied -Suited for where changes in ambient temperature are small -Calculated using the calibration value as it is
	One-gauge, three-wire configuration			<ul style="list-style-type: none"> -Suited for where simple tension, compression, or bending force is applied -Strain-gauge-lead wires are temperature-compensated. -Calculated using the calibration value as it is
	One-active gauge, one-dummy gauge configuration			<ul style="list-style-type: none"> -Suited for where simple tension, compression, or bending force is applied -Temperature compensation using a dummy gauge -Calculated using the calibration value as it is
	Two-active gauge configuration			<ul style="list-style-type: none"> -Suited for where simple tension, compression, or bending force is applied -Temperature compensation -Calculated using calibrated value $\times 1/(1+\nu)$, or signal value $\times 1/(1+\nu)$
	Two-active gauge configuration			<ul style="list-style-type: none"> -Detects bending strain -Eliminates tension and compression strain -Temperature compensation -Calculated using calibration value $\times 1/2$ or signal value $\times 1/2$
	Opposite-arm, two-active-gauge configuration			<ul style="list-style-type: none"> -Detects tension and compression strain -Eliminates bending strain -Effects of changes in temperature are doubled -Calculated using calibration value $\times 1/2$ or signal value $\times 1/2$

Table 4-2 Wheatstone Bridge Connections (1)

	<p>Opposite-arm, two-active-gauge configuration</p>			<ul style="list-style-type: none"> -Detects tension and compression strain -Eliminates bending strain -Effects of changes in temperature are doubled -Strain-gauge-lead wires are temperature-compensated. -Calculated using calibration value $\times 1/2$ or signal value $\times 1/2$
	<p>Four-active gauge configuration</p>			<ul style="list-style-type: none"> -Detects tension and compression strain -Eliminates bending strain -Temperature compensation -Calculated using calibrated value $\times 1/2 (1+\nu)$ or signal value $\times 1/2 (1+\nu)$
	<p>Four-active gauge configuration</p>			<ul style="list-style-type: none"> -Detects bending strain -Eliminates tension and compression strain -Temperature compensation -Calculated using calibration value $\times 1/4$ or signal value $\times 1/4$
	<p>Four-active gauge configuration</p>			<ul style="list-style-type: none"> -Detects torsional strain -Eliminates tension, compression, and bending strain -Temperature compensation -Calculated using calibration value $\times 1/4$ or signal value $\times 1/4$

Table 4-2 Wheatstone Bridge Connections (2)

4.2.2 Bridge Box

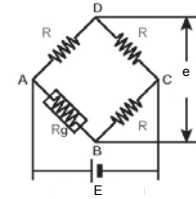
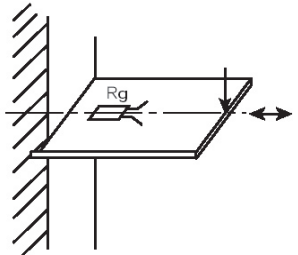
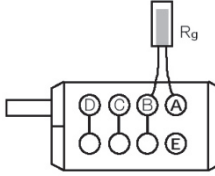
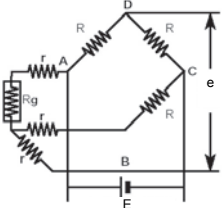
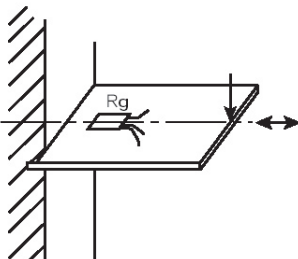
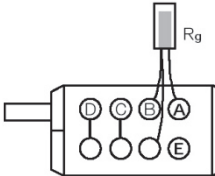
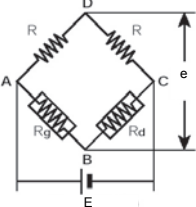
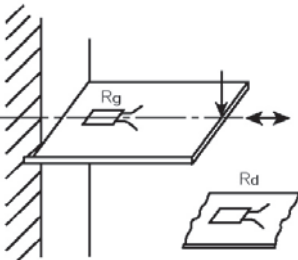
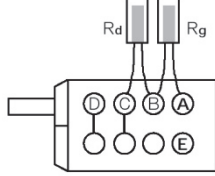
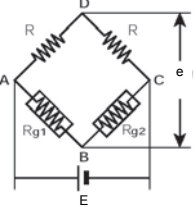
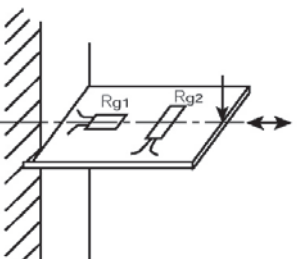
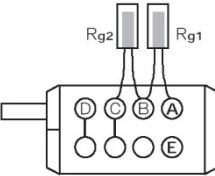
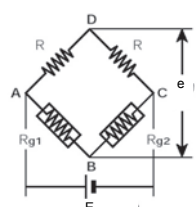
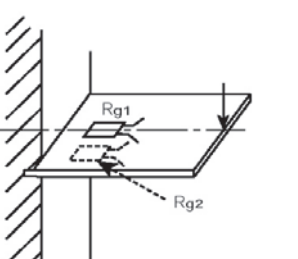
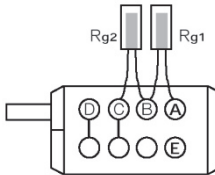
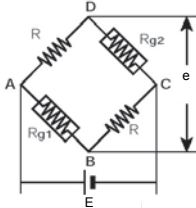
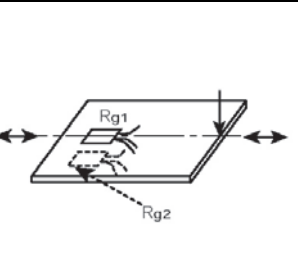
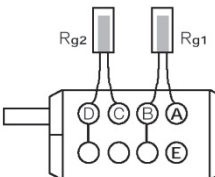
The bridge box comprises a terminal box, a cable, and a connector. The terminal box has terminals for connecting strain gauges and contains high-precision resistors (e.g., 120 Ω for 5370). The bridge circuit is formed by connecting one strain gauge or more to the terminals.

(1) Installation

- a. Install the bridge box in an area as close to the measurement point as possible.
- b. The bridge box may be secured with screws using the screw holes shown in Fig. 13, as needed.
- c. Avoid installing the bridge box where it will be exposed to high humidity, excessive temperature changes, or strong electric and magnetic fields.
- d. When the bridge box is installed, secure the interconnecting cable, if possible, and connect it to the amplifier unit.

(2) Connections to bridge box

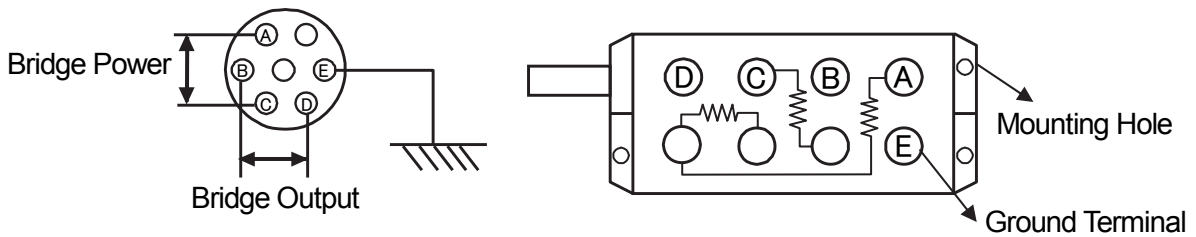

Fig.4-1 Overview of bridge box

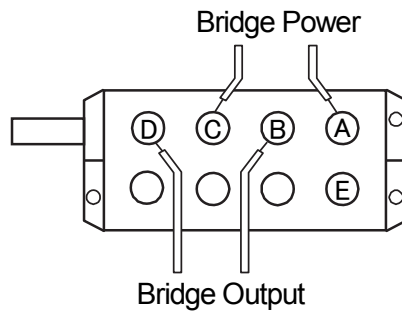

Fig.4-2 Wire connection on bridge box

- a. As shown in Fig. 4.1, pins A and C are provided for the bridge power supply, and pins B and D are provided for the input to the amplifier unit. Pin E is the common terminal.
- b. This is a bridge for measuring strain. Various methods are used for connecting strain gauges. For details on these connecting methods, refer to “Examples of Strain Gauge Bridge Configuration” on page 4-2. When using various types of transducers via the bridge box, make connections as shown in Fig. 4.2.
- c. If the cable from the bridge box or a transducer to the amplifier unit is long, the bridge voltage will drop due to the conductor resistance of the cable as shown in Table 4.4. Because the output voltage from the bridge deviates from the calibration (CAL) value due to the bridge voltage drop, the calibration value must then be corrected. For information on how to correct it, refer to “Correction of Calibrated (CAL) Value” on page 4-10. The amplifier, however, has (standard) cable length correction that provides a proper bridge voltage taking the conductor resistance of the cable into account. This enables precision measurements without having to pay attention to the difference between the output voltage and the calibration (CAL) value.

Bridge Resistance	Distance between amplifier and bridge box (m)			
	20m	50m	100m	200m
60Ω	-2.4	-5.8	-11.0	-19.9
120Ω	-1.2	-3.0	-5.8	-11.0
350Ω	-0.4	-1.1	-2.1	-4.1
500Ω	-0.3	-0.7	-1.5	-2.9
1000Ω	-0.1	-0.4	-0.7	-1.5

Table4-4 Bridge voltage drop rate (%) (0.5mm² Wire、20°C)

For information on how to correct the value, refer to “Correction of Calibrated (CAL) Value” on page 4-10.

As the amplifier can supply the bridge voltage in which cable conductor resistance is considered thanks to the cable length compensation function (standard), accurate measurement can be made without regarding the error between output voltage and calibration value.

- d. Make connections by screwing and soldering when Models 5370 is used.
- e. If the lead wires from strain gauges to the bridge box are long, the gauge factor will become apparently lower and the output linearity will deteriorate, even when the bridge has been initially balanced. The lead wires, therefore, should be as short as possible (2 m or less). The gauge factor of a strain gauge supplied with lead wires attached has been calibrated together with the lead wires. Do not cut them or add other lead wires.

4.2.3 Measurement with Transducer

In most strain-gauge-based transducers, the physical amount to be measured is applied to an elastic part, and the resulting deformation is converted into an electrical amount.

This elastic part is called the sensing part. The sensing part is made of material which exhibits a higher limit of proportionality and less creep and hysteresis. A strain gauge is cemented on the sensing part, connected so as to form a bridge, temperature-compensated and anti-humidity. For details on various types of transducers, refer to the technical manuals provided by manufacturers.

(1) Connection of transducer to the amplifier unit

When using various types of transducers with the amplifier unit, make connections as shown in Fig. 4.3. Fig 4.4 shows cables that are used for directly connecting various types of transducers to the amplifier unit. Our interconnecting cables and extension cables are manufactured in accordance with the specifications for input connectors of strain gauges specified by the Japanese Society of Non-destructive Inspection.

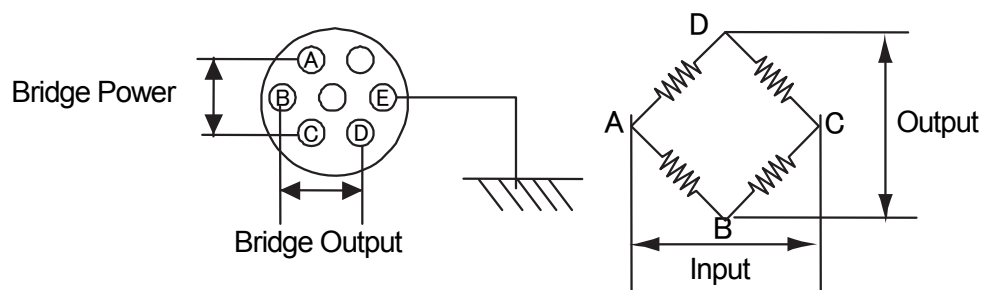

Fig.4-3 Connection of transducer to the amplifier unit



Fig.4-4 Connecting Cable

(2) Operating precautions on use of transducers

- Unstable and loose attachment of a transducer may cause malfunctioning of the amplifier unit or noise. Transducers should be securely fixed after referring to manufacturer's operation manuals.
- Although transducers and their connectors are generally moisture-proof, they should be placed to avoid water and rain so that insulation can be maintained.
- Even though the cable from the amplifier unit to the transducer is long, precision measurements can be taken because of the cable length correction feature. (Refer to page 3.6.)
- A transducer to be used must be a type on which the common (E) terminal of the amplifier unit will not be connected to another terminal (A, B, C or D).
- Do not place transducers and their interconnecting cables where they will be exposed to strong electric and/or magnetic fields

4.3 Connection of Output to Load

Two types of outputs are available; OUTPUT 1 and OUTPUT 2.

(1) OUTPUT 1 4

Delivers a voltage of ± 10 V and a current of ± 5 mA (into a load of $2\text{ k}\Omega$ or more), allowing voltage-input type instruments such as thermal dot recorders and data acquisition devices to be connected to OUTPUT 1.

Thus output is displayed on the monitoring meter (2).

(2) OUTPUT 2 5

Delivers a voltage of ± 10 V and a current of ± 10 mA (into a load of $332\ \Omega$ or more).

The output voltage of OUTPUT 2 can be varied from ± 10 V to approximately ± 1 V with the level adjustment control (18). Because this output can be displayed digitally on the digital monitor (3), it can also be displayed as a physical amount by adjusting the output voltage (scaling).

4.3.1 Connection of Output to Data Recorder

Special care must be taken with the input level of data recorders. Especially with frequency-modulated data recorders, if an input signal greater than the allowable input level of the data recorder is applied, it may be overmodulated, causing failure in recording. To avoid this, the amplifier unit is capable of displaying excessive output voltage.

As shown in Fig. 4.5, if the input signal exceeds the threshold level (approximately ± 10.5 V), an LED located on the right or left side of the reading blinks for a certain period of time. An excessive level up to a frequency of approximately 1 kHz can be checked on the monitoring meter

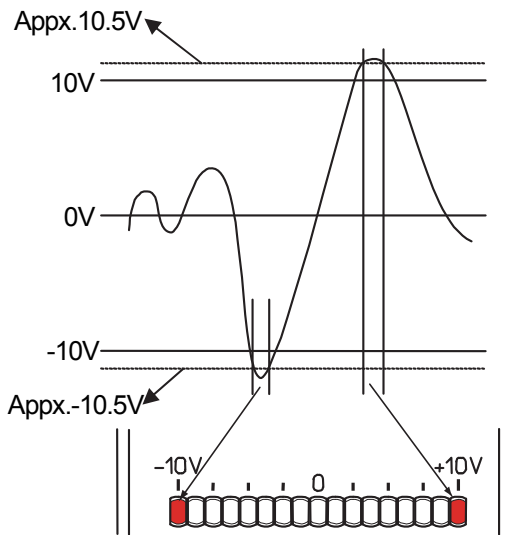

Fig 4-5

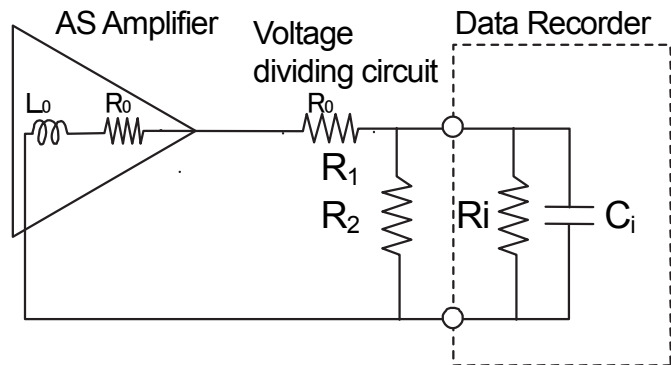

Fig 4-6

Care must be taken concerning the following points for connection to a data recorder.

(1) Where direct connections can be made

If a data recorder is capable of accepting a signal of more than 20 V_{p-p} ($\pm 10\text{V}$), it can be directly connected to the amplifier unit.

(2) Where a voltage divider is required

If the input level of a data recorder is +/-1 V, a voltage divider is required. Pay due care to the impedance.

In general, since the output impedance increases as the frequency band becomes higher, it is expressed as: $R_0(\Omega) + L_0(\mu H)$.

If a voltage divider is inserted as shown in Fig. 4.6, this will cause errors, as described in the following example.

Example:

Errors will be caused as shown in Table 4.5, if the voltage dividing ratio is 1/10 under the following conditions:

Input impedance of data recorder: $R_i=100\text{ k}\Omega$, $C_i=100\text{ pF}$

Output impedance of the amplifier unit: $R_0=1\Omega$, $L_0=200\text{ }\mu$

R_1 ($\text{k}\Omega$)	R_2 ($\text{k}\Omega$)	Error due to Voltage Dividing Circuit (%)				
		DC	1kHz	2kHz	5kHz	10kHz
90	11.1	-0.08	-0.08	-0.09	-0.12	-0.24
9	1.01	-0.02	0.02	-0.02	-0.02	-0.02

Table4-5 Error due to Voltage Dividing Circuit

4.4 How to Read Measured Values

This section describes how to read the measured values of a waveform recorded on a data acquisition device or recorder.

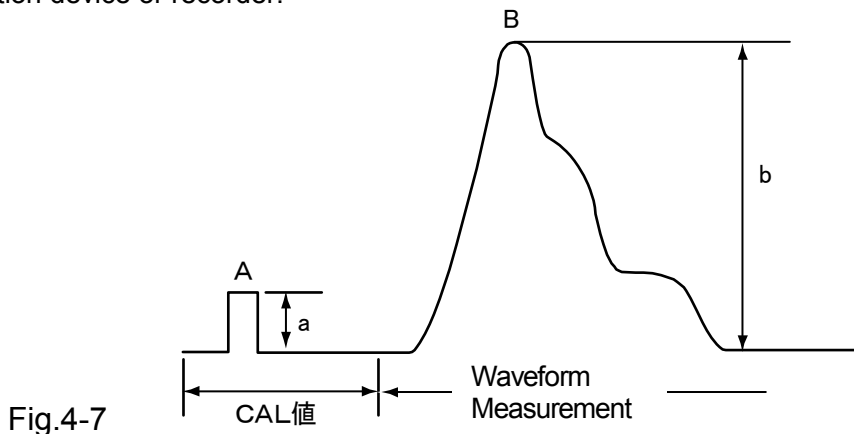

$$\text{Measured value at point B} = \left\{ \frac{b \text{ (Amplitude at point B)}}{a \text{ (Amplitude of calibration value)}} \right\} \times \text{Set CAL value}$$

(1) Measurement with strain gauges

Set CAL value: $500\text{ }\mu\text{m/m}$

Deflection of CAL waveform: 10 mm

Deflection at point B: 22 mm

$$\begin{aligned} \text{Amount of strain at point B} &= \left\{ \frac{22}{10} \right\} \times 500\text{ }\mu\text{m/m} \\ &= 1100 \times \mu\text{m/m} \end{aligned}$$

Where the measurement is based on the quarter-bridge configuration with a gauge factor of 2.00.

(2) Measurement with various types of transducers

This calibration voltage value is linked with the bridge supply voltage, and the amount of calibration can always be applied with any panel-indicated value (1 μm/m to 9,999 μm/m).

Example:

If a load cell with a rated capacity and a rated output of 1 ton and 1 mV/V is used, to convert the rated output of 1 mV/V into an amount of strain, the rated output is given by:

$$1\text{mV/V} \times 2\text{V} = 2\text{mV}$$

Where the load cell is used with the bridge voltage (E) = 2V.

If the measurement is based on the quarter-bridge configuration with a gauge factor (K) of 2.00, the relationship between the amount of strain (ε) to be applied to the bridge and the output voltage (e) is given by:

$$e = 1/4 \times K \times E \times \epsilon = 1/4 \times 2 \times 2 \times \epsilon = \epsilon$$

That is, 1 μm/m strain corresponds to 1 μV and 1000 μm/m to 1 mV. The rated output of 2 mV corresponds to 2000 μm/m. As a result, the relationship between calibration values and the physical amount is as follows irrespective of the bridge supply voltage:

Calibration Strain	Calibration Physical Amount
2000 × 10 ⁻⁶ Strain	1 ton × 1 = 1 ton
1000 × 10 ⁻⁶ Strain	1 ton × 1/2 = 500kg
500 × 10 ⁻⁶ Strain	1 ton × 1/4 = 250kg
200 × 10 ⁻⁶ Strain	1 ton × 1/10 = 100kg

Table4-6

The formula is as follows:

$$\text{Calibration value of physical amount} = \frac{\text{Calibration value for } 10^6 \text{ strain of the amplifier}}{\text{Rated output value (} 10^6 \text{ strain)}} \times \text{Rated capacity}$$

The physical amount can be calculated as follows:

Calibration value of physical amount: 250 kg (500 μm/m)

Deflection of CAL waveform: 10 mm

Deflection at point B: 22 mm

The physical amount can be calculated as follows:

$$\text{Load at point B} = \frac{22}{10} \times 250 \text{ kg} = 550 \text{ kg}$$

4.4.1 Correction of Calibration (CAL) Values

(1) Where gauge factors are not 2.00

In this amplifier unit, its gauge factor is set to 2.00. If strain gauges with a gauge factor other than 2.00 are to be used, the following formula must be used.

$$\text{True CAL value} = \frac{2.00}{Kc \text{ (Gauge factor of strain gauge)}} \times \text{CAL value of unit}$$

(2) Where bridge configurations are not quarter-bridge configuration

The calibration (CAL) values of this amplifier unit are equivalent voltage values based on the 2.00 gauge factor and the quarter-bridge configuration. The calibration values based on half- or

full-bridge configurations can thus be obtained by referring to the next table.

The relationship between the bridge supply voltage and bridge output voltage can be represented by the following formula:

$$e = (K \times \epsilon \times E \times \text{Bridge configuration})/4$$

Where: K; gauge factor

ϵ ; Amount of strain (10 $\mu\text{m}/\text{m}$)

E; bridge voltage

	Method	True calibration value
Two Gauge	One active one dummy	Calibrated value on display $\times 1$
	Two active	Calibrated value on display $\times 1/2$
	Opposite arm, two active	Calibrated value on display $\times 1/2$
Four Gauge	Four active	Calibrated value on display $\times 1/4$
Transducer	Four active	Calibrated value on display $\times 1/4$

Table4-7

For details, refer to the remarks in the “Wheatstone Bridge Connections Table” on pages 4.3-4.4.

*Although transducers are generally based on the full-bridge configuration, their output is made to match the quarter-bridge configuration.

(3) Where the distance from the bridge box to the amplifier unit is long

If the cable from the bridge box or a transducer to the amplifier unit is long, the bridge supply will drop due to the conductor resistance of the cable. This causes errors between the bridge output voltage and the CAL value. For obtaining the voltage drop rate, refer to “Bridge Voltage Drop Rate” on page 4.6 or measure the voltage drop rate between terminals A and C on the bridge box, using a voltmeter.

Example:

If the cable length is 100 m and the strain gauge resistance is 120 Ω under an ambient temperature of 20°C, the bridge supply voltage will be reduced by 5.8% between terminals A and C, which can be obtained from the “Bridge Voltage Drop Rate Table” on page 4.6. The true calibration value can thus be given by:

$$\text{True calibration value} = \frac{1}{1 - 0.058} \times \text{Calibration value on display}$$

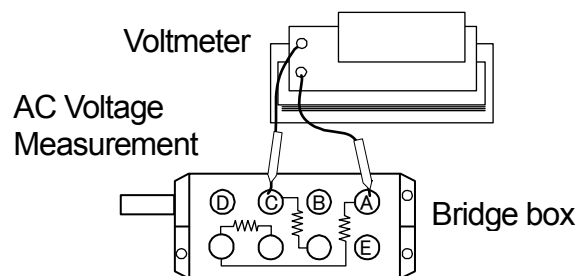

Fig.4-8 Voltage measurement on bridge box

Such measurement and adjustment are not needed in AS series amplifiers thanks to cable length compensation.(Page 3-7).

4.5 Special Applications

This section describes how to use the amplifier unit with a slip ring or differential transformer.

4.5.1 Slip Ring

(1) When using four slip rings on each lead of the bridge

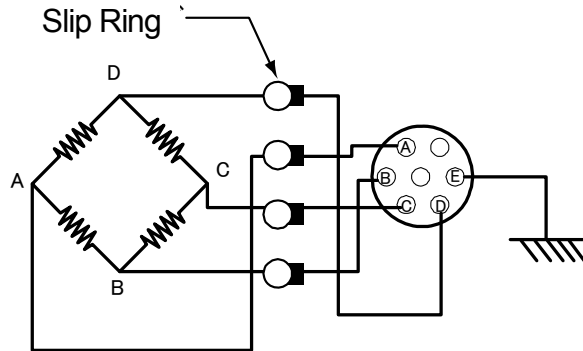

Fig4-9

Do not connect terminal E to any of the A, B, C or D terminals

(2) When conducting multi-channel measurement using a common bridge power voltage

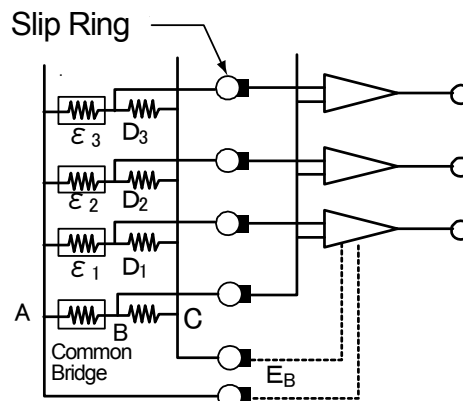

Fig4-10

Synchronize the amplifier units with each other and supply bridge power E_B from any one of the units. Since the current capacity of the bridge power is approximately ± 35 mA in this case, the bridge resistance values and number of bridges are limited.

The input impedance of this amplifier unit is very high, thereby enabling measurement with less interference between channels.

If multi-channel measurement is to be conducted, it is necessary to install a separate bridge power voltage.

4.5.2 Differential Transformers

Differential transformers are generally designed to provide high sensitivity. Because differential transformers output signals with relatively high amplitude, it is necessary to lower the voltage of the bridge power or reduce the sensitivity. Thus, the amplifier unit should be used observing its allowable input range. Use a differential transformer that has an exciting frequency of 5 kHz. If the differential transformer to be used outputs a large amplitude signal, it should be used in conjunction with this signal conditioner.

5 . Operation Theory

5.1 Flow of Measurement Signal (Refer to Fig.5-1)

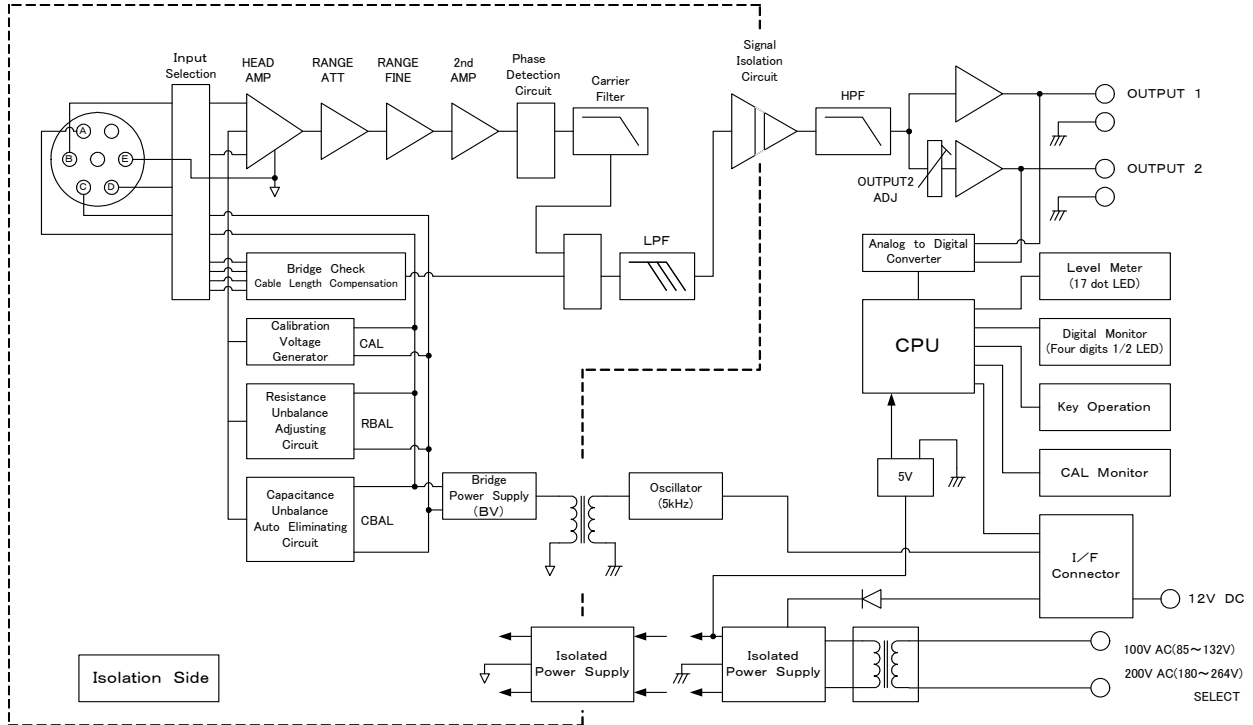

Fig.5-1 Block diagram

The signal fed from the bridge box or a transducer is applied to the INPUT connector of this product and amplified through a low-noise preamplifier. To this preamplifier are added the outputs of a 4-digit digital calibration voltage generating circuit (CAL), a resistance unbalance adjusting circuit (R BAL) and a capacitance unbalance auto eliminating circuit (C BAL), only the signal of which is fed to the subsequent stage. The signal, which has been amplified through a main amplifier, is synchronously detected and filtered, and then outputted via a signal isolation circuit and HPF. There are two output systems: the output of OUTPUT1 is displayed on a level meter, while the output of OUTPUT2 is displayed on a digital monitor. The output of an oscillator is also isolated by a transformer and fed to the isolation side, and then used as bridge power supply.

6 . Optional Function

6.1 Current Output(AS16-201 4 – 20 mA output unit)

Current output can be incorporated into the amplifier unit as an optional function. The current output is made in a manner that allows the voltage output to OUTPUT2 to be converted into the current output. When the output voltage of this product is changed from 0 to +10 V, the output current ranging from 4 to 20 mA can be provided. The central conductor of the BNC connector delivers an output current, while its outer conductor serves as an output common. Turn the OUTPUT 2 level ADJ volume, which is located on the front panel, fully clockwise. When the polarity of the output voltage varies from positive to negative, the output current starts decreasing from 4 mA to approximately 0 mA. This 4 – 20 mA output unit can be built into the body of this product if requested upon the delivery order (with extra cost). To add this current output option to the already purchased product, contact our sales representative since your product needs to be modified. (Separately charged)

■ Specifications

Output current range: Approximately 0 – 20 mA or larger, Input voltage: 0 – 10 V
 Current: 4 – 20 mA, Load: 500 Ω or less, Output resistance: Approximately 5 MΩ,
 Voltage/current conversion accuracy: ±0.1% or less

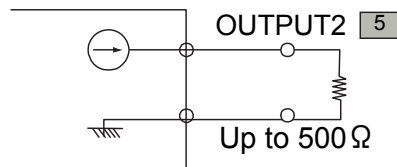

Fig.6-1

6.2 Case Function and Type

	Number of CH	TYPE
Bench-top Case	4CH	AS16-104
	6CH	AS16-105
	8CH	AS16-106
Rack-mounting Case	8CH	AS16-107

Table6-1 Two Type of Case

We provide cases listed in Table 6-1. Select the case based on the number of channel to be used.

6.2.1 Accommodating Amplifier Units

When accommodating amplifier units into a case, first the slit on the bottom of the unit should be adjusted to the guide of the case. Press the amplifier unit slowly so that the power supply and interface connectors are connected securely. After installing all amplifier units, fix them with two screws at the top and bottom of the front face an amplifier unit

6.2.2 How to Mount Blank Panel

Blank panels are used to cover the area of a case where amplifier units are not installed. To fix the panel to the case, use top and bottom screws.

6.2.3 Connecting Grounding Wire

When an amplifier unit is connected to a case, the protective grounding terminal, case protective grounding terminal, grounding terminal of batch power supply connector are connected and have the same potential.

WARNING

The grounding wire should have AWG16 wire material and connected with a screw. Always connect the grounding wire to ground.

6.2.4 Caution on Rack-mount Case

A rack-mount case is a case that is used for accommodating a case to 19-inch rack. The rails on the left and right should be placed on the rails of the rack, and then fix the case by using four attaching holes. When using several cases, install a fan unit between cases in order to release heat and maintain amplifier accuracy.

CAUTION

Avoid placing a rack-mount case on a desk or floor as the rack-mount case is no provided with rubber legs.

7 . MAINTENANCE

7.1 Items to Be Checked

We ship our products after conducting quality control, which covers from design to manufacturing. It is, however, possible that failures may occur in the products due to natural degradation, components defects, or wire disconnection.

If a failure occurs, it is necessary to find the cause. In such case, check the following items and refer to page 4-1. If the cause cannot be found, contact our sales agency. Before returning, be sure to inform us of problematic points.

⚠WARNING

- Check the power supply voltage range
Power supply voltage range: 85 to 132VAC/180 to 264VAC
12VDC (10 to 30VDC)
- Check input strain range
Input voltage range: 200×10^{-6} to $200,000 \times 10^{-6}$ strain (for AS1603, AS1803R)
Input voltage range: 500×10^{-6} to $500,000 \times 10^{-6}$ strain (for AS1703)
- Check common-mode voltage
Withstand voltage between input and output: 1.5kVAC for one minute.

First check the power supply voltage.

- Power Supply Voltage Range
DC Power Supply Voltage: 10-30V
AC Power Supply Voltage: 85-132V 50 or 60 Hz

Symptom 1 The bridge is out of balance

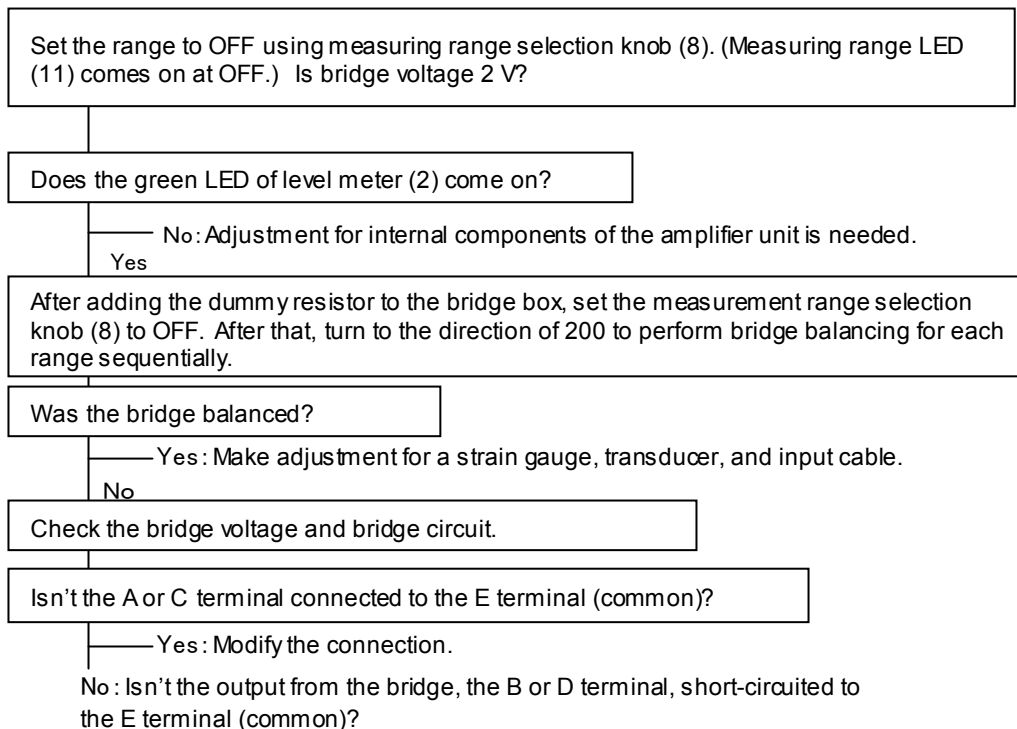
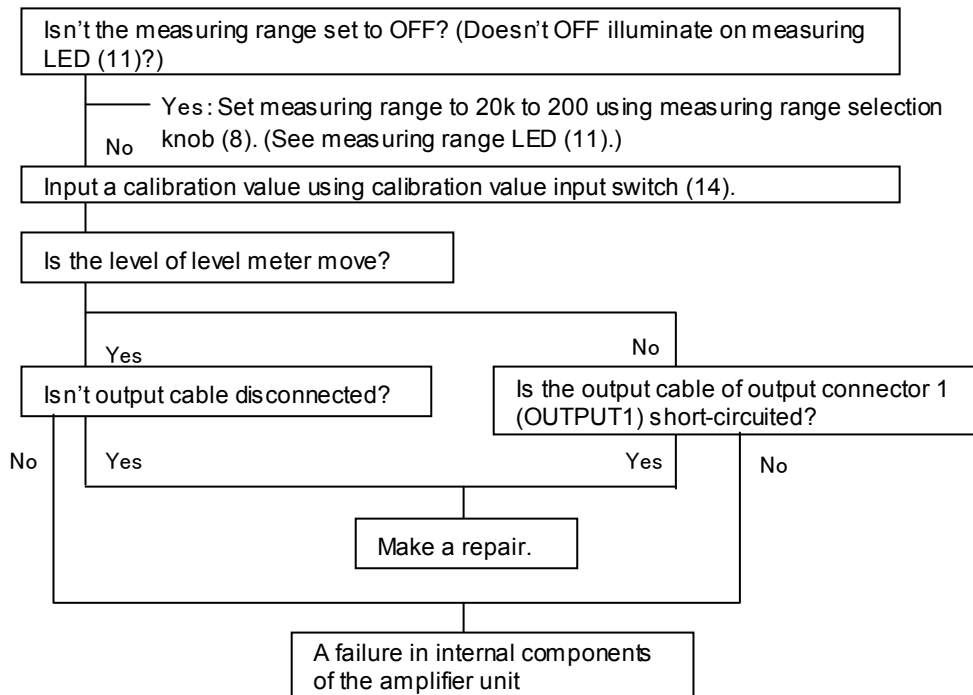

Fig. 7-1 Check Item Chart (1)

Symptom 2 No signal is output.



Symptom 3 The bridge is balanced but the zero position drift with time.

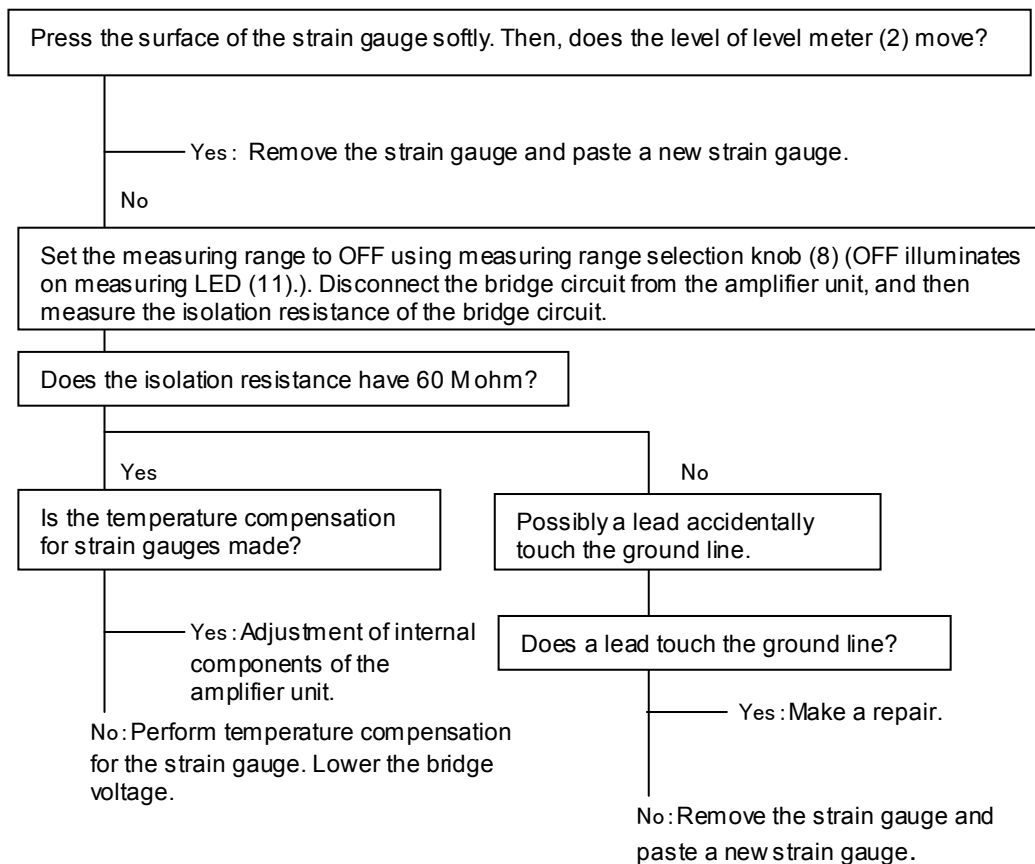

Fig. 7-1 Check Item Chart (2)

7.2 How to Replace Fuse

Follow the following fuse replacement procedure.

1. Turn the power switch to off, and then disconnect input and output cables from the amplifier unit.
2. As shown in Figure 7-2, place the amplifier unit so that the front of the unit to be left side, bottom of the unit to be in the front, and the rear of the unit to be right side.
3. Use a flat-blade screw driver and turn the fuses to the arrow directions mentioned on the fuse holders. (See Figure 7-3, counter-clockwise)

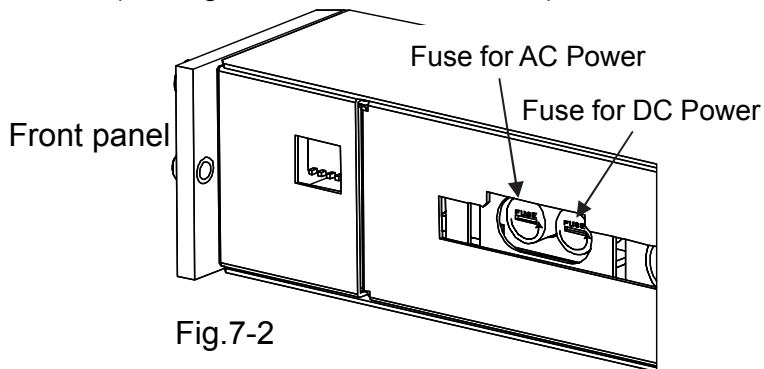

Fig.7-2

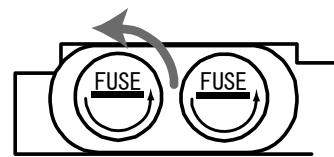

Fig.7-3

4. Replace the fuses at the front part of the fuse holders.
5. The fuse ratings are: 100 VAC and 100 mA for AC power fuse and 12 VDC and 500 mA time-lag fuse (slow blowing) for DC power supply fuse. When replacing, be careful of AC and DC.
6. When installing fuse holder, use a flat-blade screw driver. When pushing the fuse, keep the fuse holder slit to be vertical to the amplifier unit (Figure 7-5, dotted line), and then press deeply and turn clockwise by 90 degree.

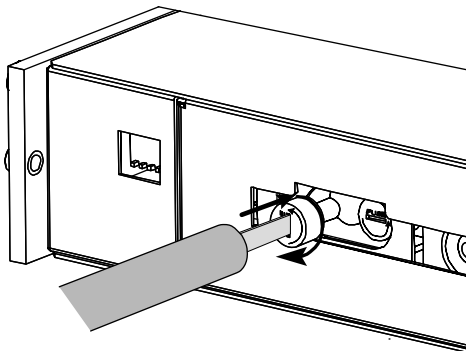

Fig.7-4

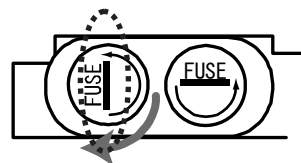

Fig.7-5

7. Confirm that the fuse holder is fully installed in the amplifier unit as Figure 7-2. Also, confirm that the fuse holder slit (flat-blade screw driver contact portion) is parallel to the amplifier unit.
8. The fuse replacement is completed. Examine why the fuse was brown. After taking measures, turn on the amplifier.

WARNING

- Power cord and input/output cable should be disconnected from the amplifier unit.
- Rated and specified fuse should be used.

7.3 Changing AC Power Supply Voltage

Follow the steps below to switch the AC power supply voltage

1. Turn off and disconnect the power cord and input/output cable from the amplifier unit
2. Remove the cover using two screws (M3) on the top face (Figure 7-6).
3. The AC power supply selection switch is positioned at the location shown in Figure 7-7. Selection to 200 VAC, OFF, and 100 VAC is available. Voltage switching is available by sliding the switch to the target voltage position. The fuse can support both 100 VAC and 200 VAC. The installed fuse (100 VAC/200 VAC, 100 mA: 0334-3006) can therefore be used for both supply voltages.
4. Attach the amplifier cover so that the slit of the amplifier cover matches to the frame of the amplifier unit.
5. Fasten the screws of upper face.
6. When using 200 VAC power supply, use optional AC power cord 200 V (Figure 7-8: 0311-5112).

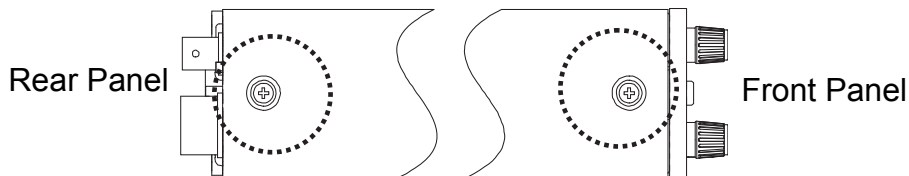

Fig.7-6

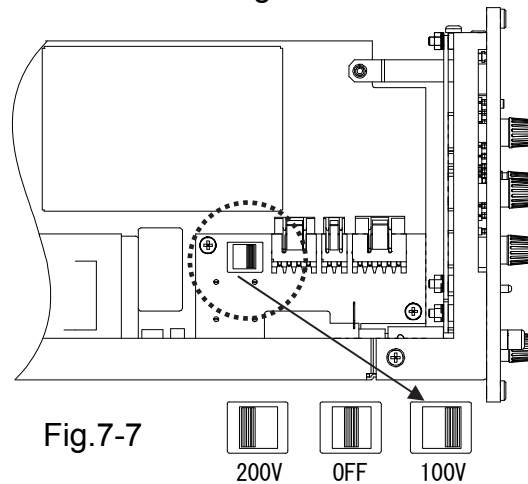

Fig.7-7

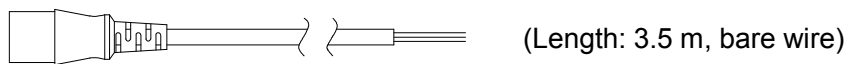

Fig.7-8 AC Power cord for 200V

⚠ WARNING

- Power cord and input/output cable should be disconnected.
- As the AC power cord 200 V (0311-5112) has bare wire at one end, processing is needed to connect to the power source.
- After switching the power supply voltage, change the power supply voltage rating indicated on the plate on the amplifier cover.

8 . SPECIFICATIONS

Item	Description
Number of Channels	1 channel/unit
Bridge resistance	60 - 1,000 Ω
Gage factor	2.00
Bridge power voltage supply	AS1603, AS1803R: AC0.5V, 2V 5kHz sine wave, Sync input/output signal 2.5 VAC AS1703: 0.5VAC, 2V 25kHz sine wave, Sync input/output signal 2.5 VAC
Disconnection check function	Detecting disconnection and short of input bridge circuit (bridge impedance of 120 Ω or larger) and displaying checked result by LED Function ON/OFF is available by using the bottom setting SW
Cable length adjusting function	Automatic adjusting of bridge power voltage drop according to a change of cable length up to bridge circuit (bridge impedance of 120 Ω or larger). Function ON/OFF is available by using the bottom setting SW
Balance adjusting range (Auto-balance)	Deviation of resistive value: $\pm 2\%$ ($\pm 10,000 \times 10^{-6}$ strain) Capacitive imbalance : Approx. 2,000 pF
Balance adjusting accuracy	AS1603, AS1803R: Within $\pm 0.4 \times 10^{-6}$ strain (RANGE = 200, Without FINE, BV = 2 V) AS1703: Within $\pm 1.0 \times 10^{-6}$ strain (RANGE = 500, Without FINE, BV = 2V)
Maximum input range	AS1603, AS1803R: $\pm 200,000 \times 10^{-6}$ strain (BV = 0.5V, RANGE = 20k, FINE = $\times 2.5$) AS1703: $\pm 500,000 \times 10^{-6}$ strain (BV = 0.5V, RANGE = 50k, FINE = $\times 2.5$)
Voltage sensitivity	AS1603, AS1803R: ± 10 V / $\pm 200 \times 10^{-6}$ strain input AS1703: ± 10 V / $\pm 500 \times 10^{-6}$ strain input
Measurement range change	AS1603, AS1803R: 200, 500, 1k, 2k, 5k, 10k, 20k ($\times 10^{-6}$ strain, $\times 2$ /BV in value), OFF AS1703: 500, 1k, 2k, 5k, 10k, 20k, 50k ($\times 10^{-6}$ strain, $\times 2$ /BV in value), OFF
Fine adjustment	Continuously changeable in FINE RANGE, 2 step changing amount can be selected
Internal calibrator	Set value: $\pm 1 - 9,999 \times 10^{-6}$ strain, Accuracy: $\pm (0.5\% \text{rdg} + 0.5 \times 10^{-6} \text{ strain})$
Nonlinearity	AS1603, AS1803R: $\pm 0.1\%$ /FS, AS1703: $\pm 0.2\%$ /FS
Frequency response	AS1603, AS1803R: DC – 2 kHz $\pm 10\%$, AS1703: DC – 10 kHz $\pm 10\%$
High-pass filter	0.5Hz: 2-pole Butterworth type (Filter descent response: – 12 dB/oct)
Low-pass filter	AS1603, AS1803R: 10, 30, 100, 300, 500 Hz 4-pole Butterworth type (Filter descent response: -24 dB/oct) AS1703: 10, 30, 100, 500, 3kHz 4-pole Butterworth type (Filter descent response: -24dB/oct)
Stability	Zero drift: Within $\pm 0.1 \times 10^{-6}$ strain/ $^{\circ}\text{C}$, Within $\pm 0.5 \times 10^{-6}$ strain/24h Sensitivity: Within $\pm 0.05\%$ / $^{\circ}\text{C}$, within $\pm 0.2\%$ /24h

Table 8-1. Specification List for AS1000

Item	Explanation
Noise level	AS1603, AS1803R: 2.0×10^{-6} strain p-p RTI (W/B, RANGE = 200, Without FINE, BV = 2V, 120 Ω in bridge) 0.6×10^{-6} strain p-p RTI (DC - 100Hz, RANGE = 200, Without FINE, BV = 2V, 120 Ω in bridge) AS1703: 6.0×10^{-6} strain p-p RTI (W/B, RANGE = 200, Without FINE, BV = 2V, 120 Ω in bridge) 2.0×10^{-6} strain p-p RTI (DC - 100Hz, RANGE = 500, Without FINE, BV = 2V, 120 Ω in bridge)
Output	OUTPUT1 ± 10 V ± 5 mA, OUTPUT2 ± 10 V ± 10 mA Output impedance: 0.5 Ω or less, Capacitive load: Operable up to 0.1 μ F (For output current of 4 - 20mA: Load impedance: 500 Ω or less, Output impedance: Approx. 5 M Ω , Voltage/current conversion accuracy: Within $\pm 0.1\%$)
Output adjustment	OUTPUT2 ADJ (Can be independently varied continuously from 1 to 1/10)
Output monitor display	17-dot LED display (OUTPUT1 monitor) Green LED at center blinks when voltage is within approximately ± 100 mV. LEDs at both ends blink when voltage is greater than approximately ± 10.5 V.
Digital display	4 1/2 digital display (OUTPUT2 monitor), Scaling display available with OUTPUT2 ADJ Accuracy: Within $\pm 0.05\%$ rdg ± 1 count, Displaying location of decimal point can be changed by using the bottom setting SW.
Key lock function	Turning the key lock ON/OFF by pressing the key lock button approximately for one second. (Except CAL switch and BV selection switch)
Setting value saving	Saving the value in flash memory. (Can be held without back-up battery)
Resistance to vibration	29.4m/s ² (50Hz, X,Y,Z, 10 minutes for each) and conforming to MIL-STD-810F 514.5C-1
Withstand Voltage (Insulation resistance)	AS1603, AS1803R: 1 kVAC, 1 minute, between each input terminal (A, B, C, D, E), output and housing case 1.5 kVAC, 1 minute, between AC power input and input, output or housing case (Includes surge resistor) 1 kVAC, 1 minute, between DC power input and input 500 VAC, 1 minute, between DC power input and output or housing case AS1703: 1 kVAC, 1 minute, between each input terminal (A, B, C, D, E), output and housing case 1.5 kVAC, 1 minute, between AC power input and input, output or housing case (Includes surge resistor) 1 kVAC, 1 minute, between DC power input and input 500 VAC, 1 minute, between DC power input and output or housing case
AC power supply	85 - 132 VAC/180 - 264 VAC (Internal switch must be changed) 9 VA or less
DC power supply	DC10 - 30V, 6 VA or less
Operating environmental conditions	- 10°C - + 50°C, Within 20 - 85% RH, without condensation
Storage temperature range	- 20°C to + 70°C, Within 10 - 90% RH
Outline dimension	H143 (± 1.0) \times W49.5 (± 0.5) \times D253 (± 2.0) mm *Excluding protrusion
Weight	Within 1.35 (± 0.1) kg

Table 8-1 Specification list for AS1000 Series (2)

9. REFERENCES

9.1. Frequency Characteristics and Phase Property

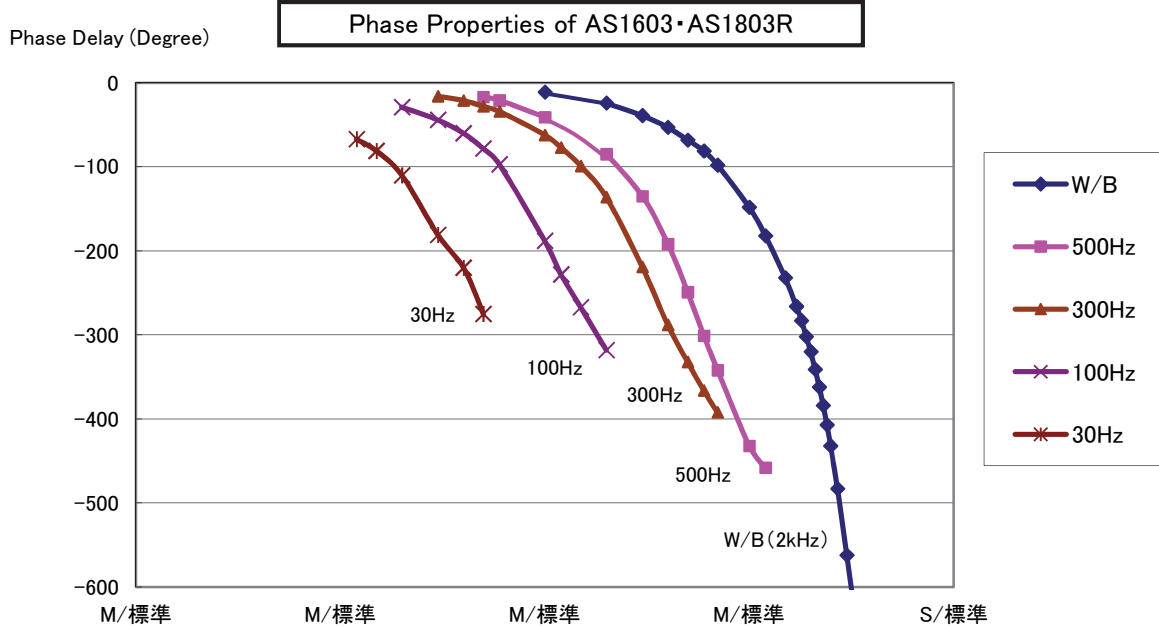
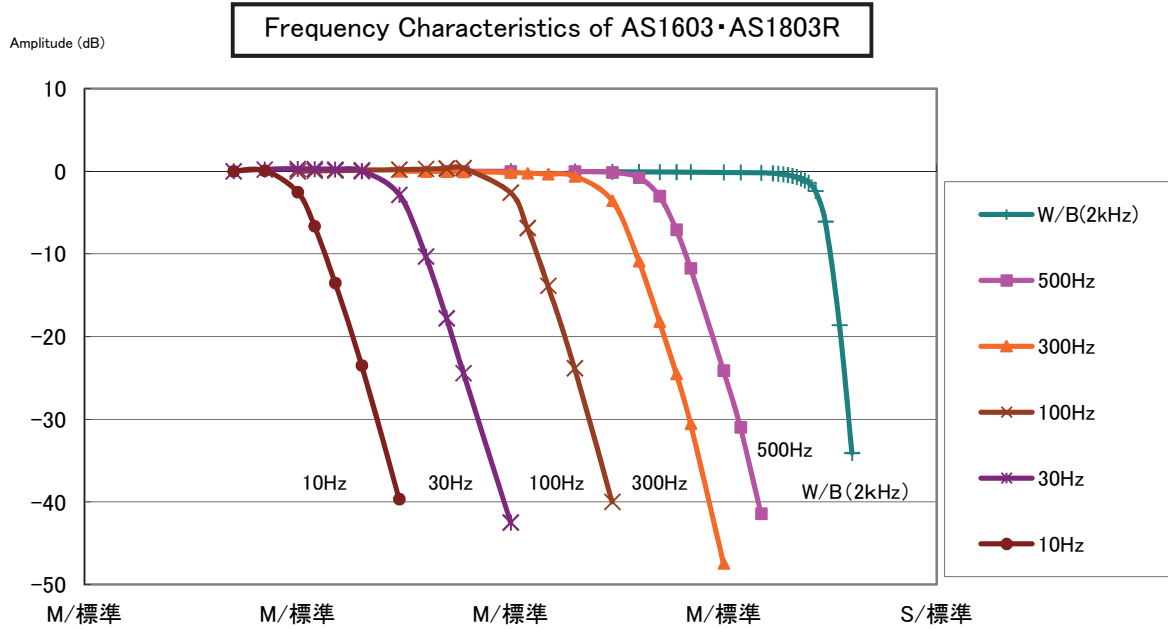

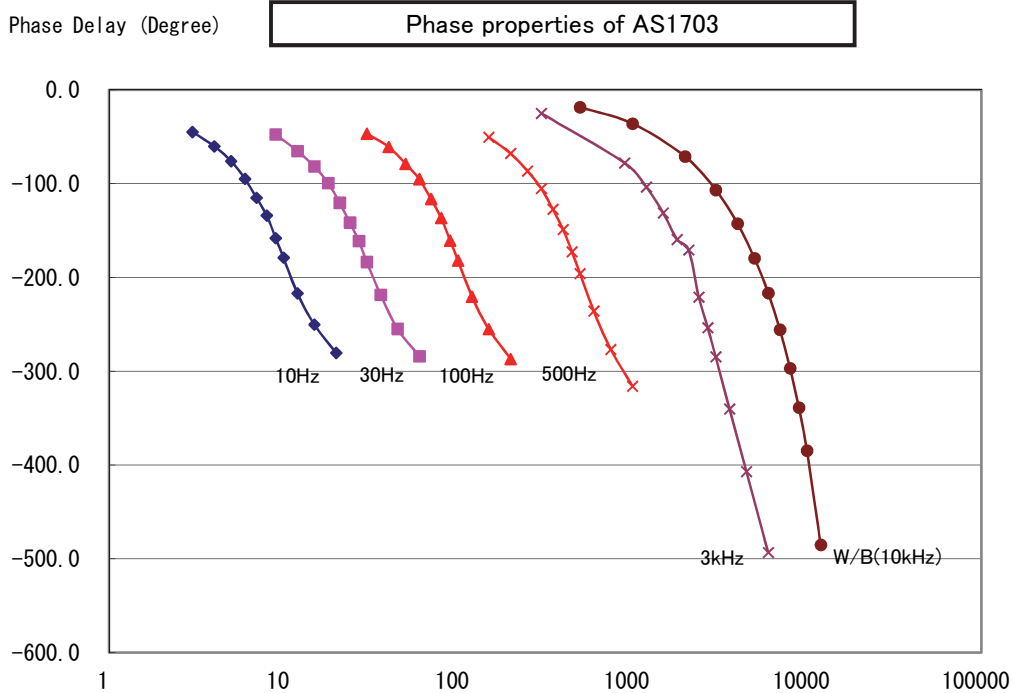
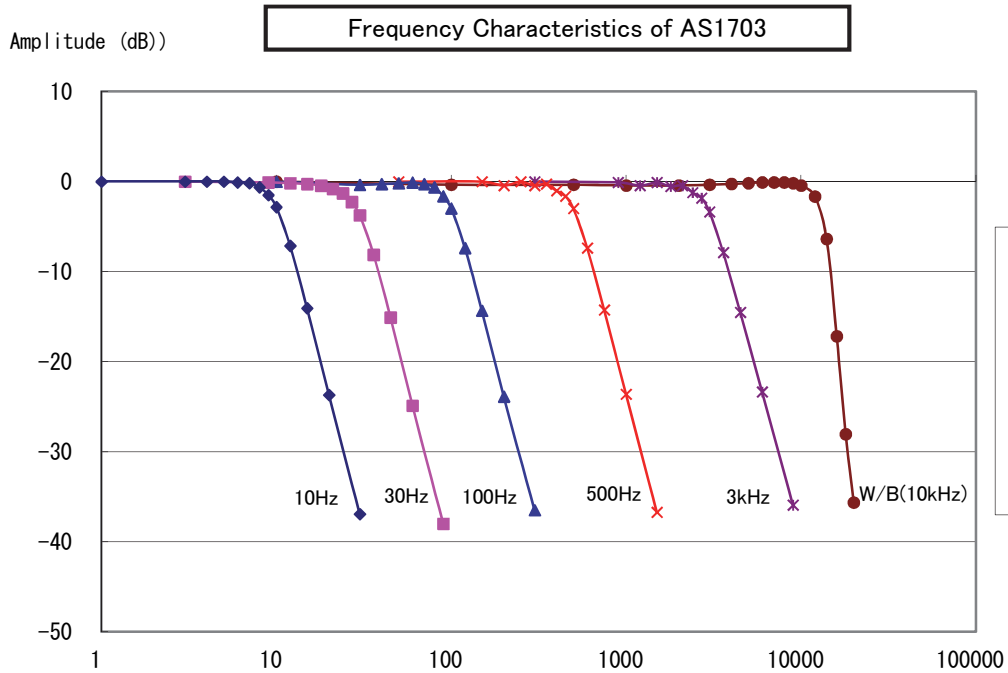

9.2 Cable List



Cables	Shapes	Pin Allocation	Remarks
Bridge Box TYPE 5370(120Ω)		A···+BV B···-Input C···-BV D···+Input E···Shield *	Length: 3m External diameter of cable Φ9.6 Core wire: 0.5mm ²
Output Cable TYPE 0311-2057 (BlackMold *) TYPE 0311-5084 (Red Mold)		Red···Output Black···Common	Length: 2m Metal BNC -alligator clip (+Red, - Black AS amplifier unit: Attached as standard (One piece)
Output Cable TYPE 47226			Length: 2m Metal BNC-Metal BNC
Output Cable TYPE 0311-5022			Length: 1m Metal BNC -Banana plug
Output Cable TYPE 0311-5174			Length: 2m Double banana plug--Metal BNC For RA connection
Output Cable TYPE 0311-5200			Length: 2m Insulated BNC —Metal BNC, For RA connection
AC Power cord (AC 100V) TYPE 0311-5044			Length: 2.5m AS amplifier unit and case: attached as standard (one)

Table 9-1 Cable List(1)

Cables	Shapes	Pin Allocation	Remarks
AC Power cord (AC 100V) TYPE 0311-5112			Length: 3.5m Bare wire
DC Power cord TYPE AS16-401		RED...DC(+) Black...DC(-) Green...Shield	Length: 2m D-sub9pin male - Bare wire
DC Power cord TYPE 47229		RED...DC(+) Black...DC(-) Green...Shield	Length: 2.5m External diameter of cable: Φ10 Core wire: 1.25mm²
Junction Cable TYPE 47230		A...+BV B...-Input C...-BV D...+Input E...Shield	Length: 10m External diameter of cable: Φ9.6 Core wire: 0.5mm²
Extension Cable TYPE 47231		A...+BV B...-Input C...-BV D...+Input E...Shield	Length: 25m External diameter of cable: Φ9.6 Core wire: 0.5mm²
Sync Cable TYPE AS16-402		①+CAL ②-CAL ③BAL ④OSC ⑤GND ⑥KEYLOCK ⑦GND ⑧(DC+) ⑨(DC-)	Length: 1.8m D-Sub9pin male ---D-Sub9pin male Straight cable ⑧,⑨: wiring is made for only amplifier unit
Sync Cable TYPE AS16-403		White...OSC Black...GND	Length: 2m D-sub9pin male - Bare wire

Table 9-1 Cable List(2)

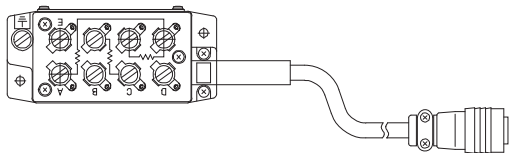
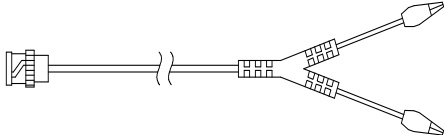
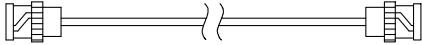
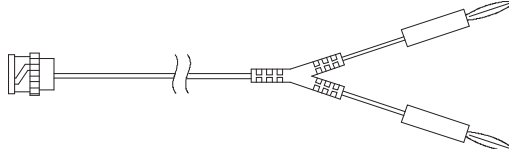
9.3 Dimensional Out line Drawing

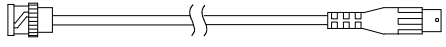
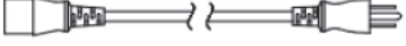
9.3.1 Unit

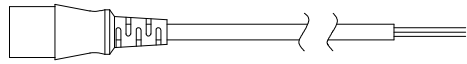
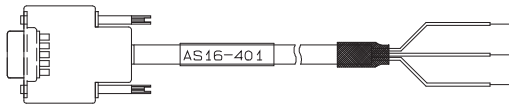
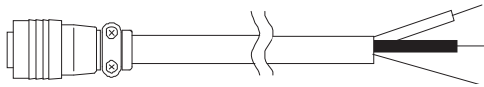
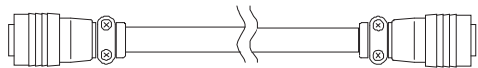
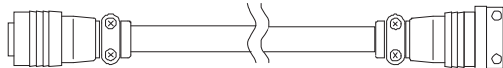
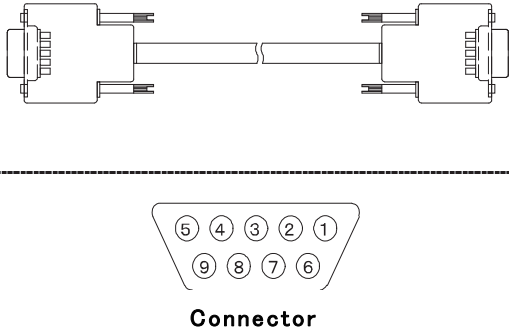
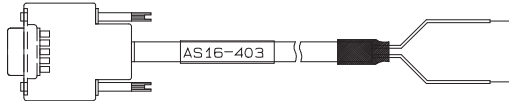
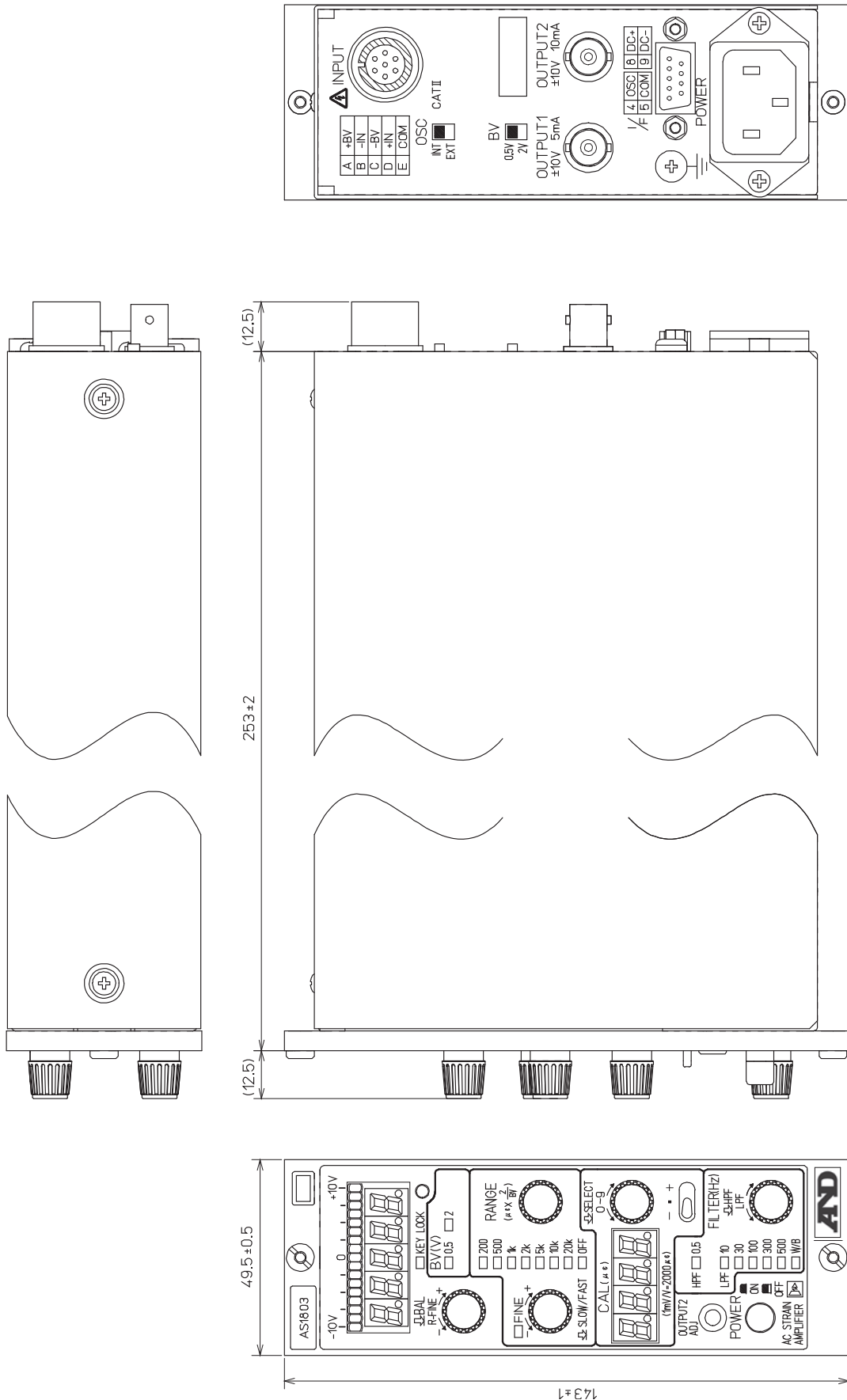

9.3.2 Panel Cut Sizes

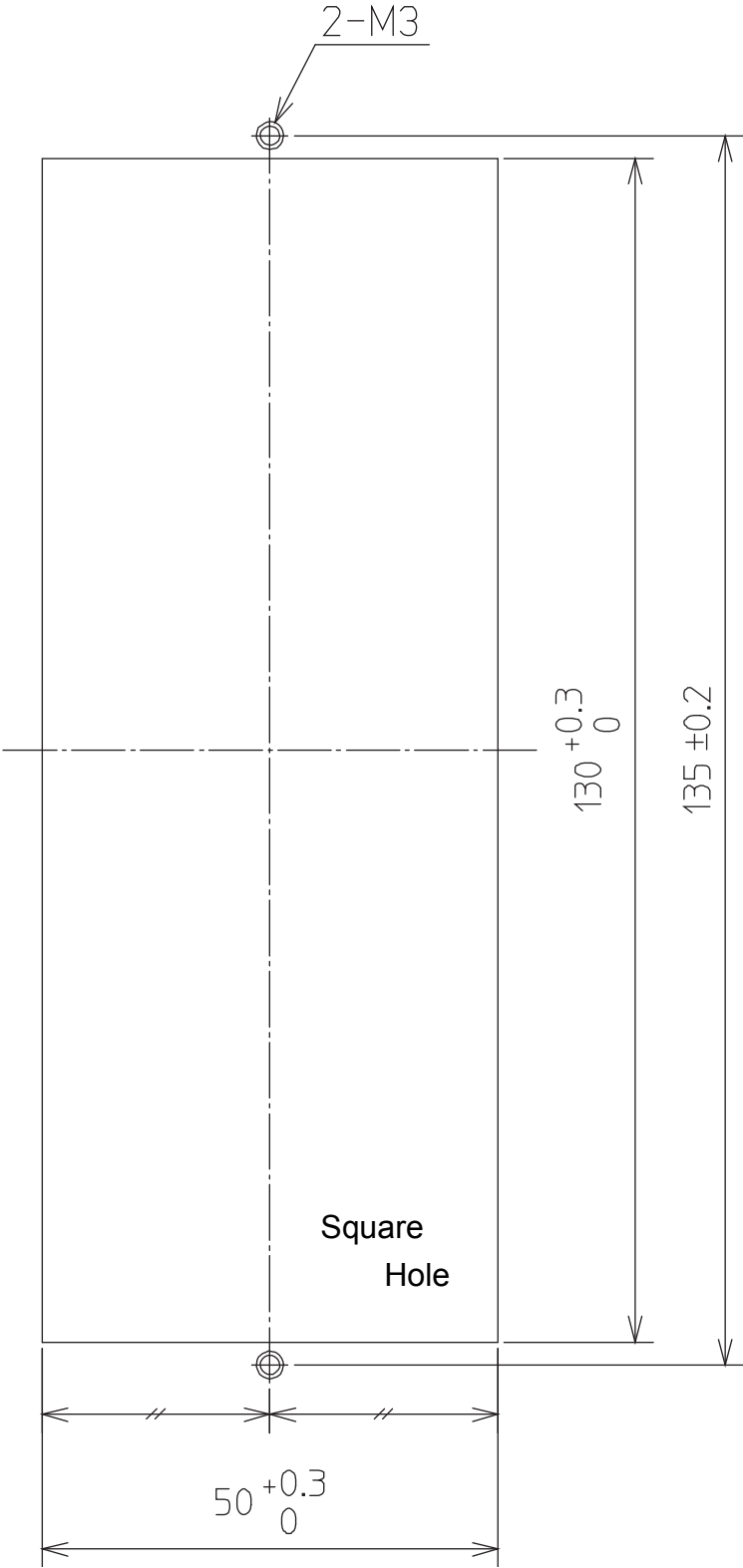

9.3.3 Bench Top Case

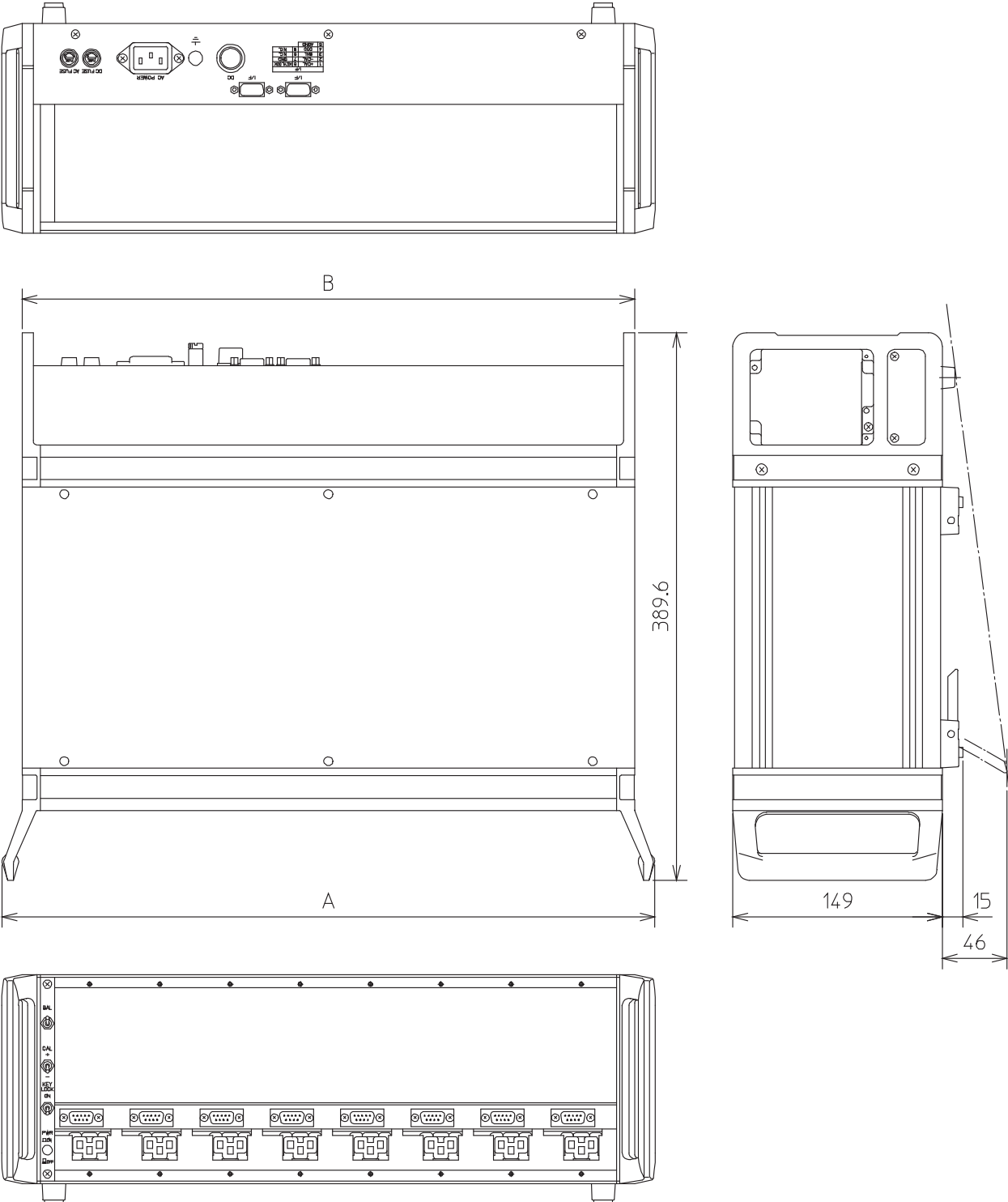

	TYPE	A	B
4CHBench Top Case	AS16-104	262.6	236
6CHBench Top Case	AS16-105	362.6	336
8CHBench Top Case	AS16-106	462.6	436

9.3.4 Rack-mounting Case

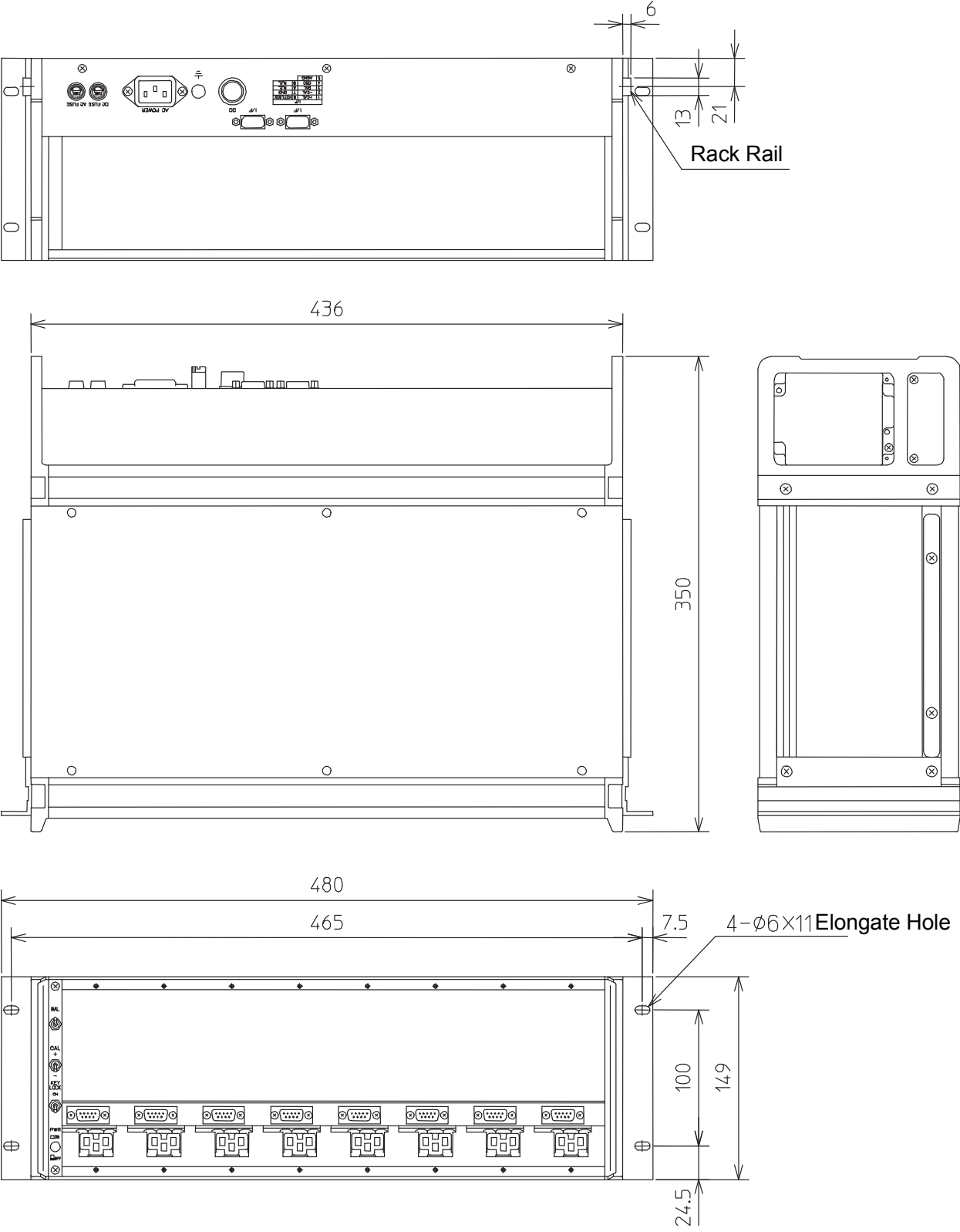

9.3.5 Fan Unit

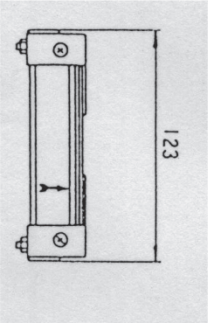
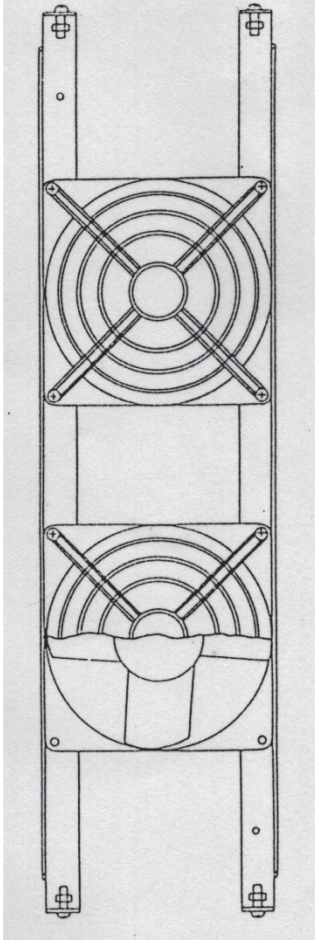
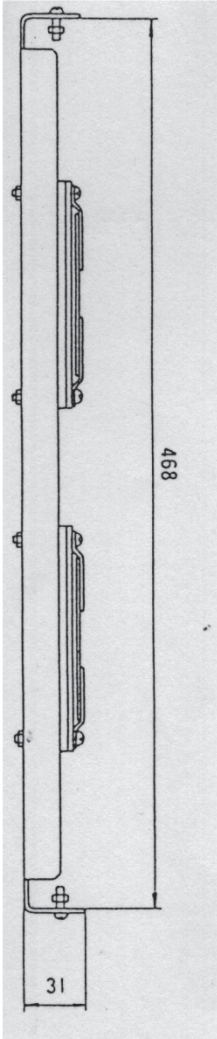

8CH Rack-mounting Case

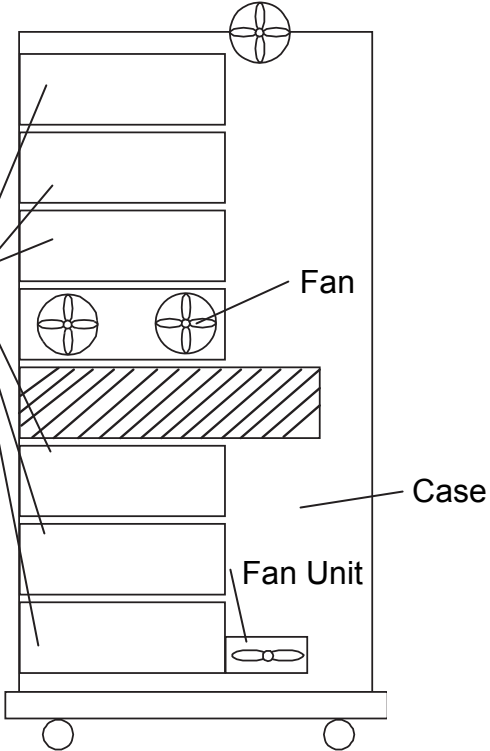

9.3.6 Bridge Box (Type 5370)

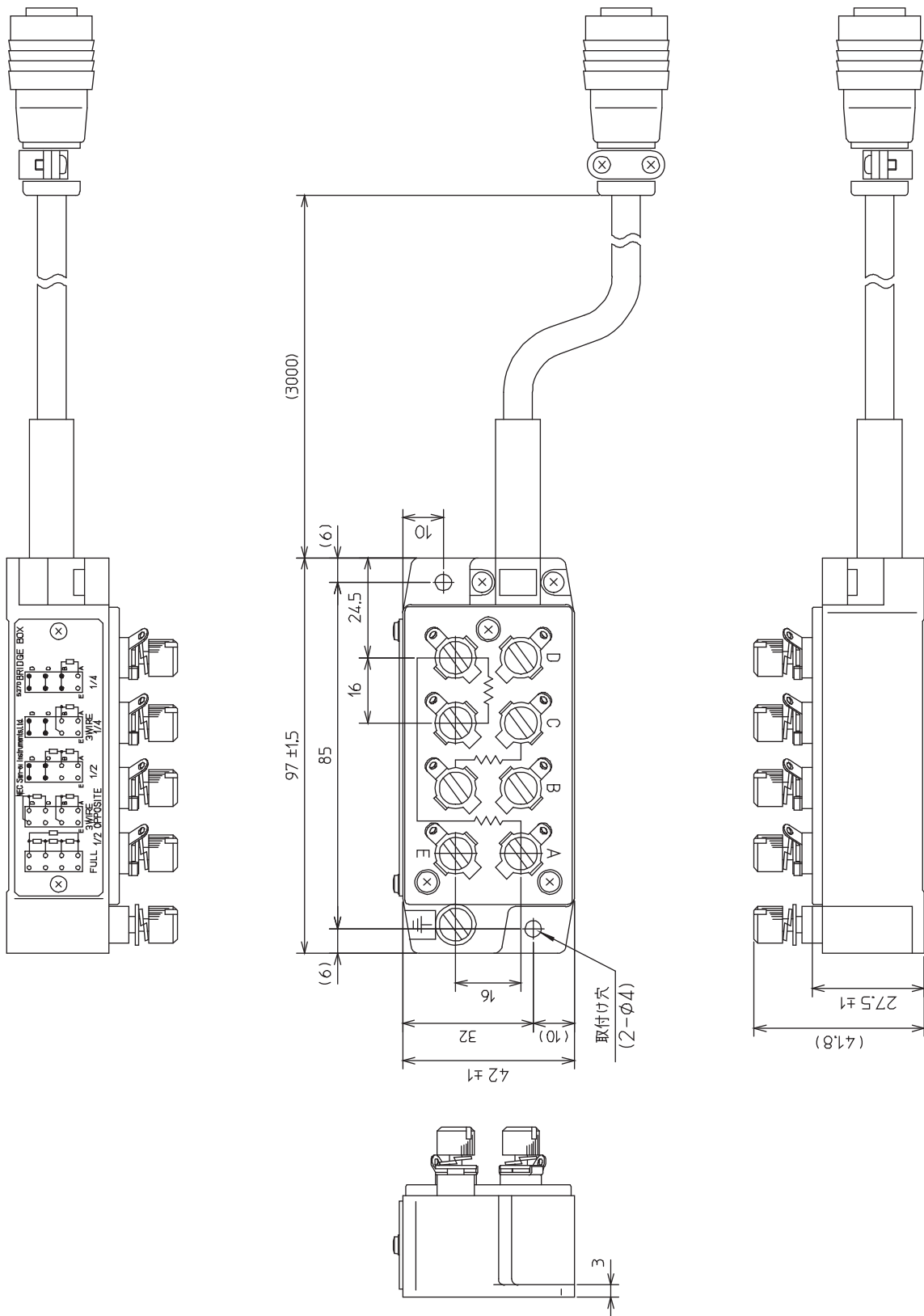

To Ensure Prolonged Use

A&D Company,Limited.

Thank you for purchasing an A&D Company,Limited. product.

To ensure prolonged use of the product that you have purchased, we offer the following lineup of maintenance services.

1. **Warranty Period**

The warranty period for this product is two years from the date of purchase. In case of a failure, the product will be repaired free of charge (only if the failure is ascribable to the responsibility of A&D).

2. **Disclaimers**

We take no responsibility for any damages caused by the following reasons;

- (1) Consequential damages and production compensation caused by any accidents of our product;
 - (2) Damages of our product generated by other companies' equipments and their construction;
 - (3) When operation, proper maintenance, and regular inspection are not done;
 - (4) Troubles which are apparently not attributable to our company or those that cannot be decided clearly whether our company is responsible for those troubles;
 - (5) Exhaustion of consumptions and repair parts;
 - (6) Troubles attributed to third party's conflicts;
 - (7) Troubles caused by a force majeure such as natural disasters
-
-

Address inquiries to:

- (1) This manual may not be reproduced to any form in whole or in part.
- (2) Then contents in this manual may be updated without prior notice.

AS1603/1703/1803R
Operation Manual (1WMPD4003384)

First Edition:	July 2005
Second Edition:	March 2008
Third Edition:	October 2012
Fourth Edition:	May 2014
Fifth Edition:	May 2015
Sixth Edition	June 2016

A&D Company, Limited



A&D Company, Limited

3-23-14 Higashi-Ikebukuro, Toshima-ku, Tokyo 170-0013, JAPAN
Telephone: [81] (3) 5391-6132 Fax: [81] (3) 5391-6148