

AL1301A

High Withstand Voltage
DC Amplifiers

INSTRUCTION MANUAL



1WMPD4003179

High Withstand Voltage DC Amplifier

AL1301A

Operation Manual



Forward

▼ Forward

Thank you very much for procuring the AL1301A High Withstand Voltage DC Amplifier. Before using this amplifier, be sure to read this manual carefully in order to use the amplifier correctly. This manual contains essential information for correctly and safely operating the amplifier. It is recommended to keep this manual near the equipment for ready reference when needed. If there are unclear points regarding the content of this manual, please feel free to contact our sales representative.

▼ Unpacking and inspecting the equipment

Especially during the winter, internal condensation can form if the equipment is brought suddenly into a warm room and unpacked. Allow ample time for the equipment to reach room temperature before unpacking.

When unpacking, visually inspect the exterior of the equipment for signs of damage. Also check the specifications, accessories and other items.

In event of damage or missing items, contact the supplier or the company business office.

▼ Keep safety in mind

Although this equipment has been designed and constructed with full attention accorded to safety, there is risk of serious injury or damage from incorrect handling or operation.

In order to avoid such hazards, be sure to read and understand the contents of this Operation Manual before using the equipment.

Do not use the equipment in a manner or for purposes not specifically covered in this manual.

▼ Notice

- The contents of this document are subject to change without prior notice.
- Transmission or copying of this document, in whole or in part, is prohibited.
- *Although every effort has been made to render this document as complete as possible, in event errors or omissions are noticed, please contact our business office.
- Regardless of the above (*), no liability is assumed for any consequences resulting from the operation of this equipment.

Safety notices

The safety notices defined below are used in various parts of this document. No liability can be assumed for injury or damage as a result of handling in a manner contrary to these notices.

WARNING

Risk of serious and possibly fatal physical injury from electric shock or other cause. This notice is provided in order to avoid such hazards.

CAUTION

Risk of damage to the equipment or the need to exercise ordinary caution.

WARNING

- **Power supply**

Be sure to first confirm the power source is within the specifications of this equipment before supplying power.

Also, in order to avoid risks of electric shock, fire or other serious hazards, use only the power cable, connecting cables supplied for this equipment.

- **Protective ground connection and protective functions**

This equipment needs to be grounded for protecting both personnel and other equipment. Carefully observe the following points.

- 1) **Grounding**

The power supply cable provided with the equipment has 3 conductors, including a ground conductor for the purpose of preventing electric shock. Be sure to connect the cable to an outlet having a ground contact.

- 2) **When supplying power to this equipment, use care the grounding conductor is not severed or the connecting wire is not disengaged from the grounding prong. Equipment safety cannot be guaranteed in these type situations.**

- 3) **Protective function defect**

In event loss of the grounding protective function is suspected, do not use the equipment. Also, before using the equipment, confirm the protective function is not defective.

- **Use in presence of gas**

Do not use the equipment in the presence of flammable or explosive gases, or in atmospheres having high water vapor content. These conditions pose hazards to both personnel and equipment.

- **Cover removal**

Operating the equipment without the provided external covers is extremely dangerous.

- **Lithium battery (disposal)**

This equipment uses a lithium secondary battery. Do not incinerate or disassemble the battery. There is danger of explosion and chemical injury from the organic electrolyte. Consult local sanitation and environmental codes regarding proper disposal of the battery.

- **Input signal connection**

Confirm the equipment is correctly and securely grounded before connecting the input. In order to avoid hazards of electric shock and damage to the equipment, confirm that a signal or common mode voltage are absent when connecting the input.

- **Warning during operation**

During operation, be aware that high voltages can appear in locations such as between the input (input signal line) and chassis (ground), and between the input and output (output signal line). Use ample care during operation to avoid electric shock accidents.

- **Installation category**

This equipment is used as Category II. Be sure to use the equipment within this range.

CAUTION

● Handling cautions

Use ample care regarding the following items when handling this equipment.

1) Restrict users

Avoid allowing persons other than those who know the correct operating procedures to use this equipment.

2) Storage and operating environments

The storage ambient temperature of this equipment is -20 to 70 °C.

Especially in the summer, do not store the equipment in locations subject to direct sunlight or high temperature (e.g., in an enclosed vehicle). Do not store or use the equipment in the following types of locations.

- ① Direct sunlight, where subject to high temperatures, such as near heating fixtures, or where subject to high humidity.

(Operating ambient temperature: -10 to 50 °C, humidity: 20 to 80 %)

- ② Wet locations
- ③ Where subject to salt, oil or corrosive gas
- ④ Humid or dusty locations
- ⑤ Where subject to strong vibration

3) Power source quality

- ① Check for power line voltage fluctuations. Do not use the equipment where these exceed the specifications.
- ② In cases such as a noisy power source or noise is induced from high voltage power lines, use a noise filter or other measures.

4) Calibration

Regular calibration is recommended for maintaining equipment accuracy. High reliability measurements are enabled by calibrating once a year (chargeable service).

Warranty conditions

Strict quality control governs every stage of our company's products from design to manufacture. In event failure is suspected during operation, check the operating procedures, power source voltage and cable connections.

Consult our nearest representative regarding service and calibration. Please provide the model name, serial number and a detailed description of the difficulty.

Our standard warranty is indicated below.

Standard Warranty

1. **Warranty period:** One year from date of purchase

2. **Warranty content:** Failures occurring during the warranty period due to manufacturing or component defects will be repaired without charge.
 - ① Damage or failure due to improper handling.
 - ② Damage or failure resulting from fire, earthquake, traffic accident or other events beyond our control.
 - ③ Damage or failure resulting from repair or modification by unauthorized personnel.
 - ④ Failure due to operation or storage under environmental conditions exceeding the specifications.
 - ⑤ Regular calibration.
 - ⑥ Damage or failure resulting from subsequent shipping or transporting after receiving.

3. **Not covered by warranty:** Charges will be assessed for repairs conducted in the following situations.

4. **Warranty scope:** This warranty does not extend to equipment and products other than those manufactured by our company.

Contents

Forward

Forward	1
Unpacking and inspecting the equipment	1
Keep safety in mind	1
Notice	1

Safety notices

Safety notices	2
WARNING	3
CAUTION	4

Warranty conditions

Warranty conditions	5
---------------------------	---

Standard Warranty

Standard Warranty	5
-------------------------	---

Contents

1. Introduction

1.1 Features	1-1
1.2 Composition	1-1
1.3 Standard accessories	1-1
1.4 Measurement block diagram	1-1

2. Part names and functions

2.1 Front panel part names and functions	2-1
2.2 Rear panel names and functions	2-2

3. Preparation

3.1	Protective ground connection	3-1
3.2	Power cable connection	3-1
3.3	Input connection	3-1
3.4	Output and load connection	3-2

4. Measurement procedure

4.1	Prior to measurement	4-1
4.2	Reading measurement	4-2

5. Operating principle

5.1	Measuring signal flow	5-1
5.2	Key and I/F signal settings	5-1

6. Installation cases

6.1	Installation case types	6-1
6.2	Amplifier unit installation	6-1
6.3	Blank panels	6-1
6.4	Protective ground connection	6-1
6.5	Rear panel terminal connections	6-2
6.6	Note when using rack mount case	6-2

7. Maintenance

7.1	Check items	7-1
-----	-------------------	-----

8. Specifications

8.	Specifications	8-1
----	----------------------	-----

9. Reference data

9.1	Frequency and phase response	9-1
9.2	Cable types	9-1
9.3	AL1301A external configuration	9-2

1. Introduction

1.1 Features

The AL1301A is a high withstand voltage DC amplifier utilizing optical fiber for input/output isolation. Compared with previous models, the amplifier is 1/4 the area and 1/2.5 times the weight.

The withstand voltage is 8 kV (1 minute) and the maximum input voltage is 2 kV.

Operation is from a flat panel, while a key lock switch can protect settings from erroneous operation.

By utilizing a benchtop or rack mount case, power can be switched on, calibrated values can be applied and key lock set for all channels simultaneously.

1.2 Composition

- High withstand voltage DC amplifier unit AL1301A
- 8 channel benchtop case
- 8 channel rack mount case
- Blank panel

1.3 Standard accessories

- AC power supply cable
- Adjustment driver
- BNC - test clip output cable
- Operation Manual (1WMPD4003179)

1.4 Measurement block diagram

Although the measuring system depends on the measured object (signal) size, frequency and measurement time, the block diagram indicates a typical system.

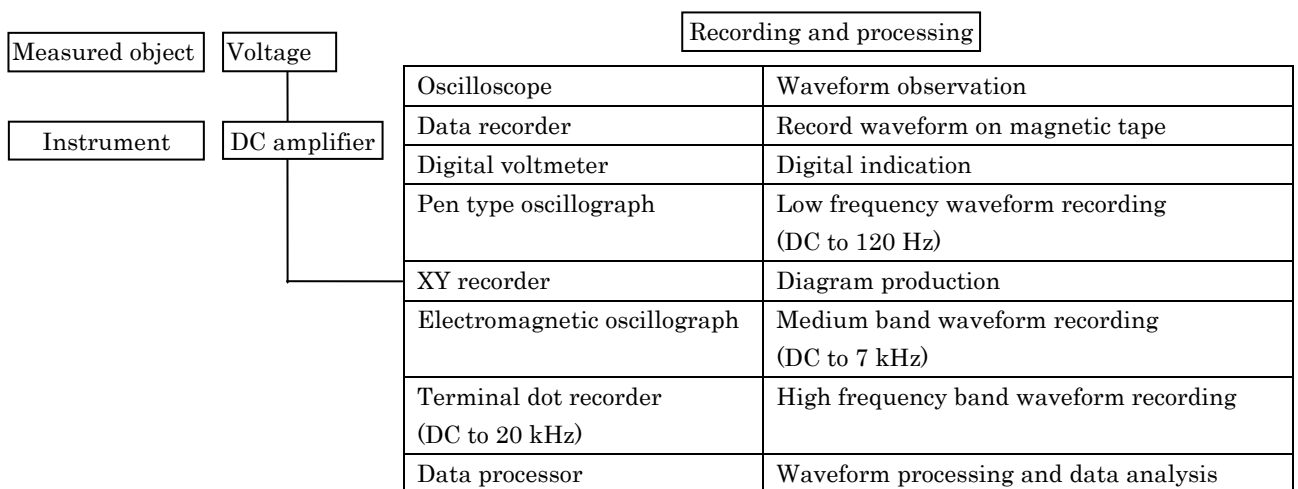

Fig. 1 Measurement block diagram

2. Part names and functions

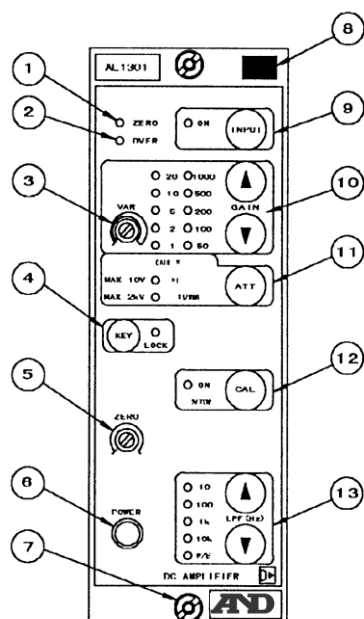

Fig. 2 Front panel

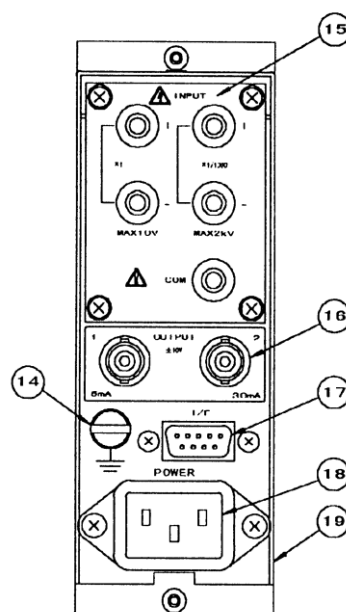

Fig. 3 Rear panel

2.1 Front panel part names and functions (see Fig. 2)

Table 1 Front panel part names and functions (1/2)

No.	Name	Functions
①	ZERO LED	Lights green when amplifier output is in the range of approximately ± 100 mV.
②	OVER LED	Lights green when amplifier output exceeds approximately ± 10.5 V.
③	VAR (Gain fine adjustment)	Gain fine adjustment control. Adjusts gain selected by the GAIN up/down buttons from $\times 1$ (fully counter-clockwise) to $\times 2.5$ (fully clockwise).
④	KEY LOCK (button and LED)	Press the button for more than 3 seconds to engage the key lock function. The LED lights and key inputs are inhibited. To release the key lock, again press the button for more than 3 seconds. The LED extinguishes and key inputs are enabled.
⑤	ZERO (Zero point adjust)	Control can adjust the output in the range of ± 1 V.
⑥	POWER (Power on/off button)	Press the button to switch power on. Again press the button to switch power off. A yellow ring at the base of the button is visible when power is off.
⑦	Mounting screw receptacle	Use when installing the unit into a case.

Table 1 Front panel part names and functions (2/2)

⑧	Channel number area	Use for indicating channel number, etc.
⑨	INPUT (Input on/off button and LED)	Press the button to connect the amplifier input to the signal line (on). The LED lights. Again press the button to disconnect the amplifier input from the signal line (off). The LED extinguishes and the input circuit is connected to common.
⑩	GAIN (Gain select buttons and LEDs)	Up/down buttons for setting the amplifier gain. Press the up button to increase the gain and the down button to decrease the gain. The selected gain multiple is indicated by the adjacent LED.
⑪	ATT (Attenuator select button and LED)	The maximum input (DC or AC peak) range is respectively ± 10 V at the $\times 1$ setting and ± 2 kV at the $\times 1/1000$ setting.
⑫	CAL (Calibration button and LED)	Press the button to apply the calibration voltage (LED lights). Again press the button to remove the calibration voltage (LED extinguishes). The output becomes +2 V multiplied by the gain set by the VAR control (2 V when VAR is fully counter-clockwise). Since the calibration voltage is overlapped on the signal, be sure to set the function off (LED extinguished) during measurement.
⑬	LPF (Lowpass filter up/down buttons and LEDs)	Buttons select the output filter. The filter is a 3-pole Bessel type (rolloff response -18 dB/octave). Cutoff frequencies are 10, 100, 1 k and 10 kHz. W/B: 100 kHz +1, -3 dB

2.2 Rear panel names and functions (see Fig. 3)

Table 2 Rear panel names and functions (1/2)

No.	Name	Functions
⑭	Protective ground terminal	Be sure to connect to ground when using the equipment.
⑮	INPUT (Input terminals)	Two sets of input terminals are provided according to the measuring range. Use the terminals selected with the ATT button. Only the COM (black) terminal is common. The measuring range is respectively ± 10 mV to ± 10 V at the $\times 1$ setting and ± 10 V to 2 kV at the $\times 1/1000$ setting. However, when VAR is fully counter-clockwise, the measuring range is 1/2.5.

Table 2 Rear panel names and functions (2/2)

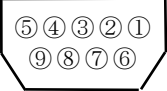
No.	Name	Functions									
⑩	OUTPUT (Output connectors)	Output 1 is ± 10 V, ± 5 mA and Output 2 is ± 10 V, ± 30 mA. Connect to a voltage input recorder (e.g., data recorder, oscillograph with DC amplifier, etc.), A/D converter or other device.									
⑪	I/F (Interface connector)	<p>Connector for electrical interfacing when the amplifier is contained in a case. Calibration voltage is applied when +CAL (pin 1) is connected to common (pin 5). Calibration can be operated by either these pins or the front panel CAL button. Similarly, the key lock function can be operated by either connecting pin 6 to pin 5, or pressing the front panel Key Lock button.</p> <p>(I/F connector pin arrangement)</p> <div style="display: flex; justify-content: space-around; align-items: center;"> <table border="1" style="border-collapse: collapse; text-align: center;"> <tr> <td>① +CAL</td> <td>② RESERVE</td> <td>③ RESERVE</td> </tr> <tr> <td>④ RESERVE</td> <td>⑤ Output common</td> <td>⑥ KEY LOCK</td> </tr> <tr> <td>⑦ RESERVE</td> <td>⑧ RESERVE</td> <td>⑨ RESERVE</td> </tr> </table> <div style="text-align: center;"> <p>I/F connector</p>  </div> </div> <p style="text-align: right;">(viewed from rear)</p>	① +CAL	② RESERVE	③ RESERVE	④ RESERVE	⑤ Output common	⑥ KEY LOCK	⑦ RESERVE	⑧ RESERVE	⑨ RESERVE
① +CAL	② RESERVE	③ RESERVE									
④ RESERVE	⑤ Output common	⑥ KEY LOCK									
⑦ RESERVE	⑧ RESERVE	⑨ RESERVE									
⑫	AC power input connector	Connector for AC power cable. The 1 minute withstand voltage rating of this unit is 8 kV between the AC power input and signal input, and 2 kV AC between the AC power input and output and case.									
⑬	Model label	A label showing serial number and other data is affixed to the left side of the cover.									

3. Preparation

CAUTION

Install this equipment in a location where the ambient temperature and humidity do not exceed -10 to $+50$ °C and 20 to 80 % RH, and where it is not subjected to strong magnetic or electromagnetic fields. The installation category of this equipment is II.

3.1 Protective ground connection

In event high voltage is produced in the input line due to ground potential difference or other reason and the insulation is breached, electrical shock accidents can be prevented by connecting the protective ground terminal to the ground. Use AWG16 or thicker wire to connect the protective ground.

WARNING

Be sure to ground this equipment when using it.

3.2 Power cable connection

Confirm the front panel power switch is off and use the accessory AC power cable to connect the unit to AC power.

The ground conductor of the power cable can be used in place of the protective ground terminal. However, be sure to ground the equipment by either of these methods.

WARNING

Confirm the power switches of this unit and other equipment are off when connecting the power, input and output cables.

3.3 Input connection

Connect the input cable properly and securely to the input terminals. Since the terminals have exposed metallic parts, use ample care during operation to avoid electrical shock accidents.

When the measured voltage is less than ± 10 V, set ATT to $\times 1$ and connect the signal to the $\times 1$ input terminals. If greater than ± 10 V, set ATT to $\times 1/1000$ and use the $\times 1/1000$ input terminals.

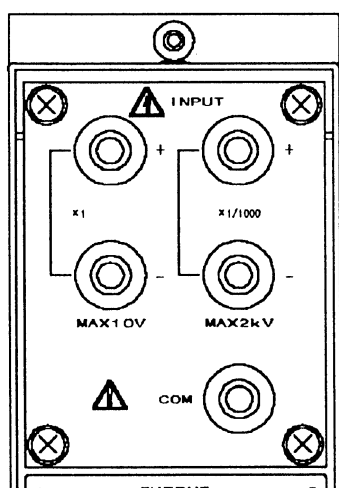

WARNING

Confirm absence of signal and common mode voltage when connecting the input cable. Also check the insulation and withstand voltage capabilities of the input cable itself.

Fig. 4 Input terminals
(1) NOISE AVOIDANCE

Keep the cable from the signal source as short as possible to minimize induced noise and suppress amplifying the noise.

In some cases, connecting either the + or - signal source to the common terminal can reduce noise.

(2) Preserving insulation

Use care to avoid dust, oil, moisture, etc. adhering to the input terminals or cover. Contamination can reduce insulation resistance and impair performance.

3.4 Output and load connection

Use appropriate cable for connecting (voltage input type) recording equipment.

The outputs of this unit are ± 10 V, 5 mA (Output 1) and 30 mA (Output 2). Connect these respectively to loads exceeding 2 k Ω and 333 Ω .

Withstand voltage between the output connectors and chassis (ground terminal) is 500 VAC 1 minute.

(1) Output cable

The accessory output cable is 3C-3V equivalent shielded cable with a BNC connector. Since the cable is not intended for particularly high withstand voltage, avoid routing the output cable in proximity to the input terminals or input cable.

(2) Recorder connection

Carefully observe the input level when connecting a data recorder. In particular, excess input can cause overmodulation with an FM type data recorder and prevent recording.

When connecting a data recorder or a recorder having a built-in DC amplifier, check that the recorder can accommodate an input level exceeding 20 V_{p-p} (± 10 V).

Also note that reducing the sensitivity of this amplifier and raising the sensitivity of the recorder impairs the signal to noise ratio (S/N).

4. Measurement procedure

4.1 Prior to measurement

The settings and basic operation are described below.

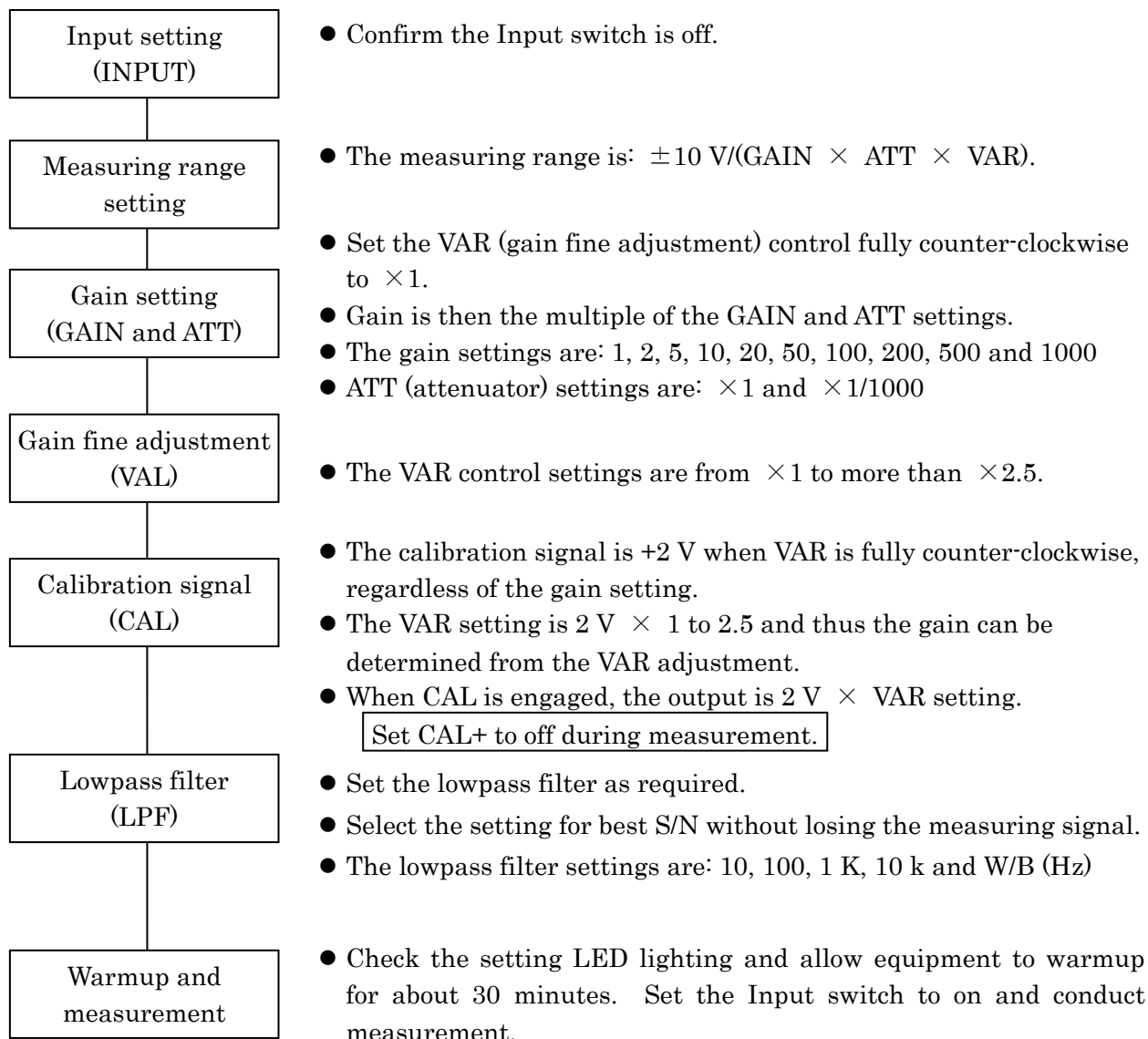

Table 3 indicates the measuring range of this equipment.

WARNING

The maximum input voltage is $\pm 10 \text{ V}$ at $\text{ATT} = \pm 10 \text{ V}$, and $\pm 2 \text{ kV}$ at $\text{ATT} = \times 1/1000$. These are the maximum input voltages that can be measured.

WARNING

The maximum permissible voltage is $\pm 30 \text{ V}$ at $\text{ATT} = \pm 10 \text{ V}$, and $\pm 2.2 \text{ kV}$ at $\text{ATT} = \times 1/1000$. There is risk of burn damage if these voltages are exceeded.

Table 3 Measuring range

Gain	ATT: ×1		ATT: ×1/1000	
	VAR fully counter-clock wise	VAR fully clockwise	VAR fully counter-clockwise	VAR fully clockwise
1000	±10mV	Approx. ±4mV	±10V	Approx. ±4V
500	±20mV	Approx. ±8mV	±20V	Approx. ±8V
200	±50mV	Approx. ±20mV	±50V	Approx. ±20V
100	±100mV	Approx. ±40mV	±100V	Approx. ±40V
50	±200mV	Approx. ±80mV	±200V	Approx. ±80V
20	±100mV	Approx. ±200mV	±500V	Approx. ±200V
10	±1V	Approx. ±400mV	±1kV	Approx. ±400V
5	±2V	Approx. ±800mV	±2kV	Approx. ±800V
2	±5V	Approx. ±2V	±2kV	±2kV
1	±10V	Approx. ±4V	±2kV	±2kV

4.2 Reading measurement

CAUTION

Supply measuring system power from the load (output) side.

WARNING

High voltage can occur during measurement between the input terminals and case, and between the input and output terminals. Use ample care to prevent electrical shock accidents during operation.

During ordinary measurements with VAR fully counter-clockwise, the measured value can be determined simply from the setting multiple. However, when gain is adjusted with VAR (or the output amplitude is adjusted), compensation is required using the CAL output.

Refer to the following formulas.

(1) VAR fully counter-clockwise

$$\text{Measured value} = \frac{\text{Output value}}{(\text{ATT value} \times \text{GAIN value})}$$

(2) Measurement using VAR

$$\text{Measured value} = \frac{\text{Output value} \times \text{CAL output (+ 2V) with VAR fully counter-clockwise}}{(\text{ATT value} \times \text{GAIN value}) \times \text{CAL output at measurement gain}}$$

5. Operating principle

5.1 Measuring signal flow

The measuring signal flow is described below.

The respective input terminals are connected to subsequent amplifier stages according to the ATT $\times 1$ or $\times 1/1000$ setting. The signal from the input terminals is sent via the input attenuator (1/1000) and fuse to the Input selector switch. The amplifier increases the gain 1 to 1000 times according to the GAIN setting. A voltage to frequency (V/F) converter produces a frequency signal from the voltage signal. The frequency signal is transferred as an optical pulse by optical fiber to the output stage.

The frequency signal is obtained as an optical pulse at the output stage. A frequency to voltage (F/V) converter produces a voltage signal and a carrier filter removes unnecessary frequency components. The resulting signal is sent via gain fine adjust (VAR), lowpass filter (LPF) and zero adjust circuits to the output circuit.

Zero and Over detectors monitor the output circuit voltage. The green Zero LED lights when the voltage is within ± 100 mV, while the red (Over) LED lights if it exceeds ± 10.5 V.

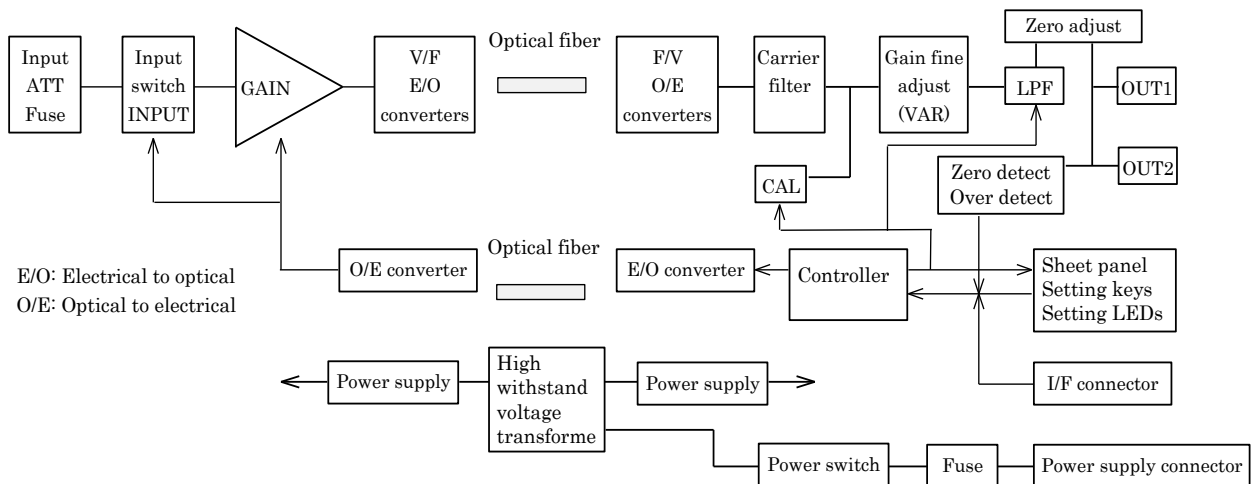

Fig. 5 AL1301A block diagram

5.2 Key and I/F signal settings

Settings with the front panel keys and rear panel I/F signals are described below.

Key and I/F signal settings are detected by the controller for setting the input and output stages. Although key lock and calibration can be operated from the I/F connector, these functions are operated via either the connector or the front panel keys.

The key lock button needs to be held depressed for longer than 3.5 seconds in order to switch the key lock function on or off. The I/F signal High level is +5 V and Low level is 0 V.

If controlling by contact signal, set the function by connecting the setting terminal to common. If controlling by TTL signal, set the function on by connecting the common circuits together and applying Low level to the setting terminal.

The settings are backed up by a Flash memory. The Flash memory life is about 20years.

6. Installation cases

6.1 Installation case types

Table 4 indicates the available types of installation cases. Select the appropriate case according to the measuring channels. Installation cases are provided with power supply and I/F connectors for the number of amplifier unit channels, together with front panel CAL and Key Lock switches, and rear panel power connector for connecting all units at once, I/F terminal strip (CAL, Key Lock, output common, etc.) and protective ground terminal.

Table 4 Installation case types

Case name	Model
8 channel benchtop case	AL13-104
8 channel rack mount case	AL13-105

6.2 Amplifier unit installation

Engage the groove at the bottom of the unit with the guide of the case. insert the unit slowly to properly connect the power and I/F connectors at the rear. After installing all channels, secure each unit from the front with two knurled screws at the top and bottom.

6.3 Blank panels

Use blank panels to cover vacant channels of the case. Secure the panels with binding head screws at the top and bottom holes used for installing units.

6.4 Protective ground connection

By installing the amplifier units in the case, the ground terminals of the units and case, and ground pins of the power connectors are connected together and are at the same potential. Use AWG16 wire for the protective ground lead and secure it with the screw.

WARNING

In the interest of safety, be sure to ground the protective ground terminal.

6.5 Rear panel terminal connections

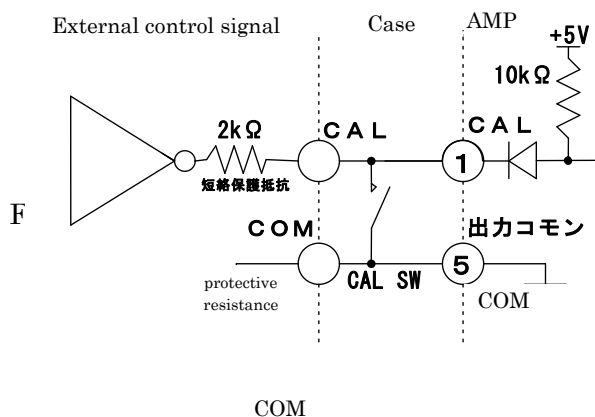

All channels can function at once by setting the rear panel CAL and Key Lock terminals to Low level.

Set to Low level by a method such as indicated in

When multiple cases are used, by connecting the corresponding terminals of the cases together, the units of all cases can function at once by setting the terminal of one case to Low level.

a) TTL and MOS signal connection

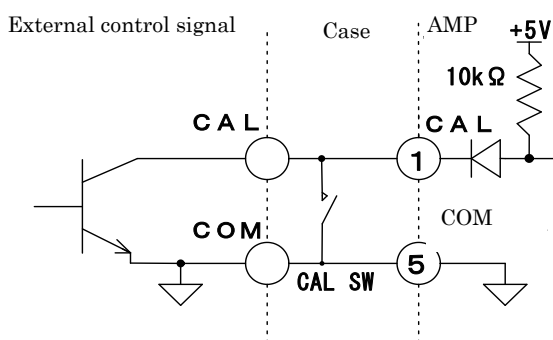

b) Open collector connection

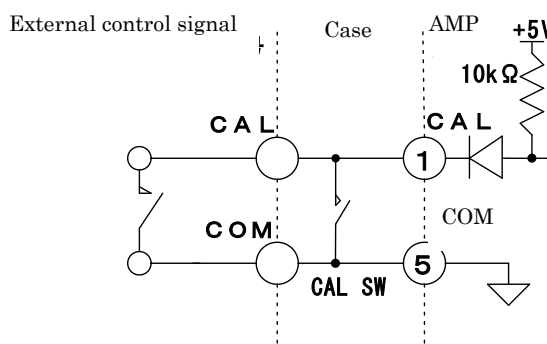

c) Contact signal connection

Fig. 6 Control from rear panel terminals

6.6 Note when using rack mount case

The rack mount case is used for installing the units in a 19-inch rack. Engage the left and right rails of the case with those of the rack and secure by using the 4 front panel holes. When installing multiple cases, a cooling fan unit is recommended between each case for maintaining measuring accuracy.

CAUTION

The rack mount case does not include feet. Avoid placing it directly on a desk, floor, etc., since there is risk of failure due to overheating.

7. Maintenance

7.1 Check items

The equipment is manufactured with strict quality control, but over the course of time, parts can deteriorate and impair performance. Abnormal operation can also result from breakdown or defective connection.

In event of abnormal operation, the cause of the problem needs to be corrected. When full performance cannot be obtained, check the items indicated in Table 5.

If the cause cannot be determined or failure is suspected, contact our service agency. Please describe the difficulty in as much detail as possible.

WARNING

- Confirm the power source voltage range.
Power source voltage range: 90 to 110 VAC
(or 220 VAC $\pm 10\%$)
- Confirm the input voltage range.
Input voltage range: ± 10 V with ATT = $\times 1$
 ± 2 kV with ATT = $\times 1/1000$
- Confirm common mode voltage range.
Input-output withstand voltage: 8 kVAC, 1 minute
3 kV
(AC peak or DC), continuous
- Be sure to correctly and securely connect the protective ground.

Table 5 Causes and corrections

Symptoms	Causes	Corrections
No power on (LED does not light)	1. Abnormal power supply 2. Power cable open or connection faulty 3. *1Power supply fuse open	<ul style="list-style-type: none"> ● Check power supply. ● Replace cable and reconnect. ● *1Replace fuse.
No output	1. Input switch off 2. Input terminal connection error 3. *1Input fuse open 4. Output cable open or connection faulty 5. Output shorted	<ul style="list-style-type: none"> ● Set Input switch to on. ● Check ATT setting. ● *1Replace input fuse. ● Replace cable. ● Check connection status.
Output small	1. Output load exceeds specification 2. Lowpass filter selection inappropriate	<ul style="list-style-type: none"> ● Check output load and current. ● Try W/B.
Output favors one side	1. Input lead open or connection faulty 2. Input terminal connection error	<ul style="list-style-type: none"> ● Replace cable. ● Check connection status.
Excess noise	1. Input connection faulty 2. Installed in strong electromagnetic field	<ul style="list-style-type: none"> ● Check shield connection. ● Change installation site.

※1. Do not replace fuse, if need be, please let us or our distributor know.

8. Specifications

1. Number of channels	1 channel/unit
2. Isolation method	Optical
3. Input format	Differential isolation input
4. Input impedance	10 M Ω + 10 M Ω (with ATT at $\times 1$, excess input, except power off), power off leak current max. 2 μ A (excess input refers to greater than max. voltage, but less than permissible voltage.)
5. Input connection	Terminals
6. Input fuses	Internal fuses (125 V, 125 mA) for protecting each input circuit
7. Input gain selection	1, 2, 5, 10, 20, 50, 100, 200, 500, 1000, $\times 1$ and $\times 1/1000$ (19 steps)
8. Gain accuracy	ATT $\times 1$: ± 0.2 %, ATT $\times 1/1000$: ± 2 %
9. Gain stability	± 0.03 %/FS/ $^{\circ}$ C
10. Gain fine adjust (VAR)	$\times 1$ to $\times 2.5$
11. Linearity	± 0.05 %/FS
12. Frequency response (W/B)	DC to 100 kHz +1, -3 dB
13. Lowpass filter	10, 100, 1 k, 10 kHz 3-pole Bessel type (rolloff response -18 dB/octave)
14. Common mode voltage (CMV)	8 kVAC/minute
15. Common mode rejection ratio (CMRR)	1 k Ω balanced input, gain $\times 1000$, VAR minimum
16. Maximum input voltage	ATT $\times 1$: ± 10 V (DC or AC peak) ATT $\times 1/1000$: ± 2 kV (DC or AC peak)
17. Permissible input voltage	ATT $\times 1$: ± 30 V (DC or AC peak) ATT $\times 1/1000$: ± 2.2 kV (DC or AC peak)
18. Stability	± 3 μ V/ $^{\circ}$ C (RTI, gain $\times 1000$, VAR minimum)
19. Noise	100 μ Vp-p (RTI, gain $\times 1000$, VAR minimum)
20. Zero adjustment range	Approx. ± 1 V
21. Calibration voltage	2 V \times VAR, accuracy ± 0.5 %
22. Output	Max. output ± 10
Voltage and current	
Output 1:	± 10 V, ± 5 mA
Output 2:	± 10 V, ± 30 mA
Output resistance	0.5 Ω
Capacitive load	Up to 0.1 μ F
23. Insulation resistance	More than 100 M Ω with 500 VDC megger (between input terminals and output, case and AC power)

24. Withstand voltage		
	Between input terminals and output, case and AC power:	8 kVAC, 1 minute
	Between AC power, and output and case:	1.5 kVAC, 1 minute
25. Power supply	100, 220VAC $\pm 10\%$	
26. Power consumption	Approx. 8 VA	
27. Operating ambient	-10 to +50 °C, 20 to 80 % RH (provided no moisture condensation)	
28. Storage ambient	-20 to +70 °C, 10 to 90 % RH (provided no moisture condensation)	
29. Net weight	Approx. 1.8 kg	
30. Dimensions	Approx. 49.5 (W) \times 143 (H) \times 254 (D) mm	
31. Supplied accessories	AC power supply cable	1
	Adjustment driver	1
	BNC - test clip output cable	1
	Operation Manual	1

9. Reference data

9.1 Frequency and phase response

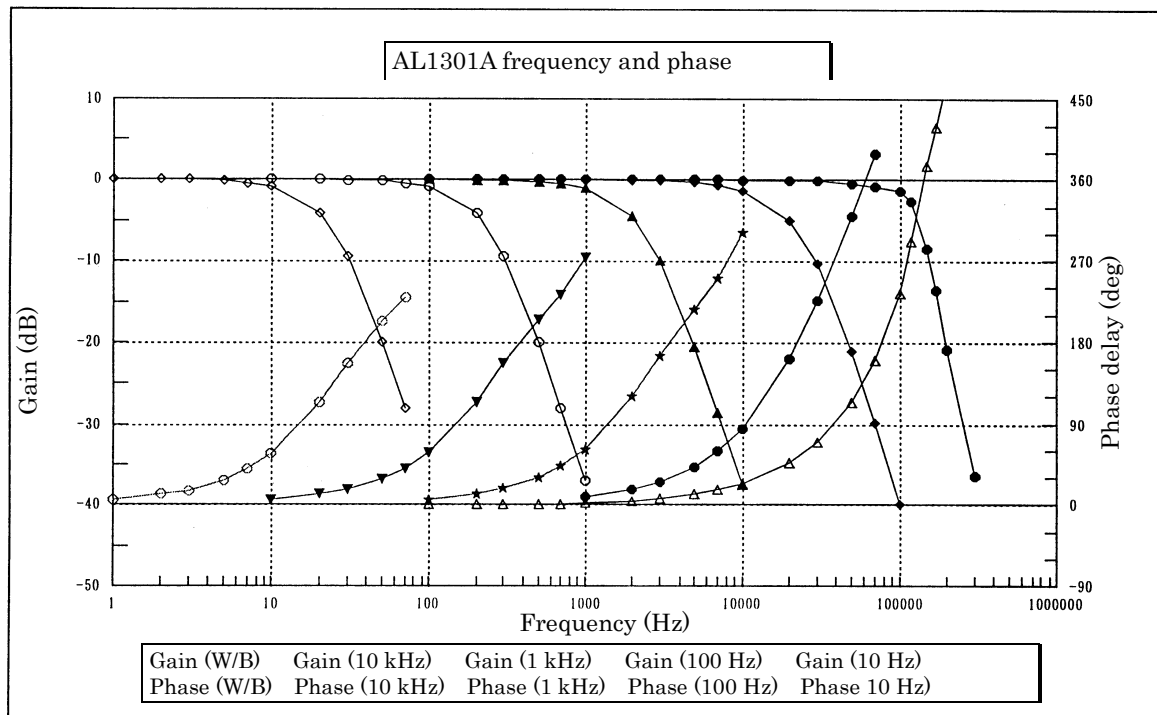

9.2 Cable types

Cable types

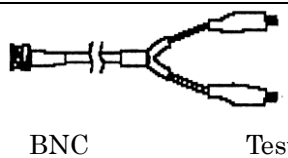
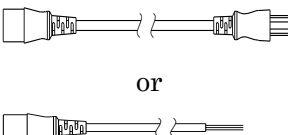
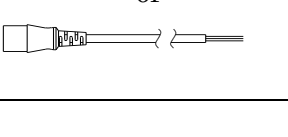
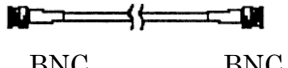
Cable name	Shape	Pin arrangement	Connector	Remarks
Output cable Type 0311-2057 (Black molded)	 BNC Test clips Length 2 m	Red: +output (BNC conductor) Black: common	DDK BNC-P58U-CR10	Standard accessory
AC power cable	 or 			Standard accessory
Output cable Type 47226	 BNC BNC Length 2 m		DDK BNC-P58U-CR10	Option

9.3 AL1301A external configuration

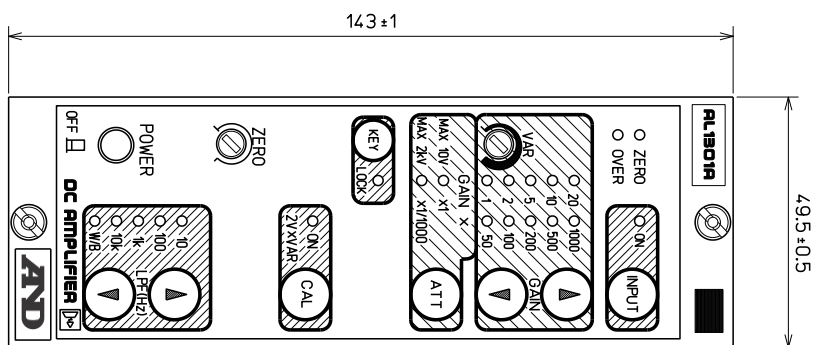
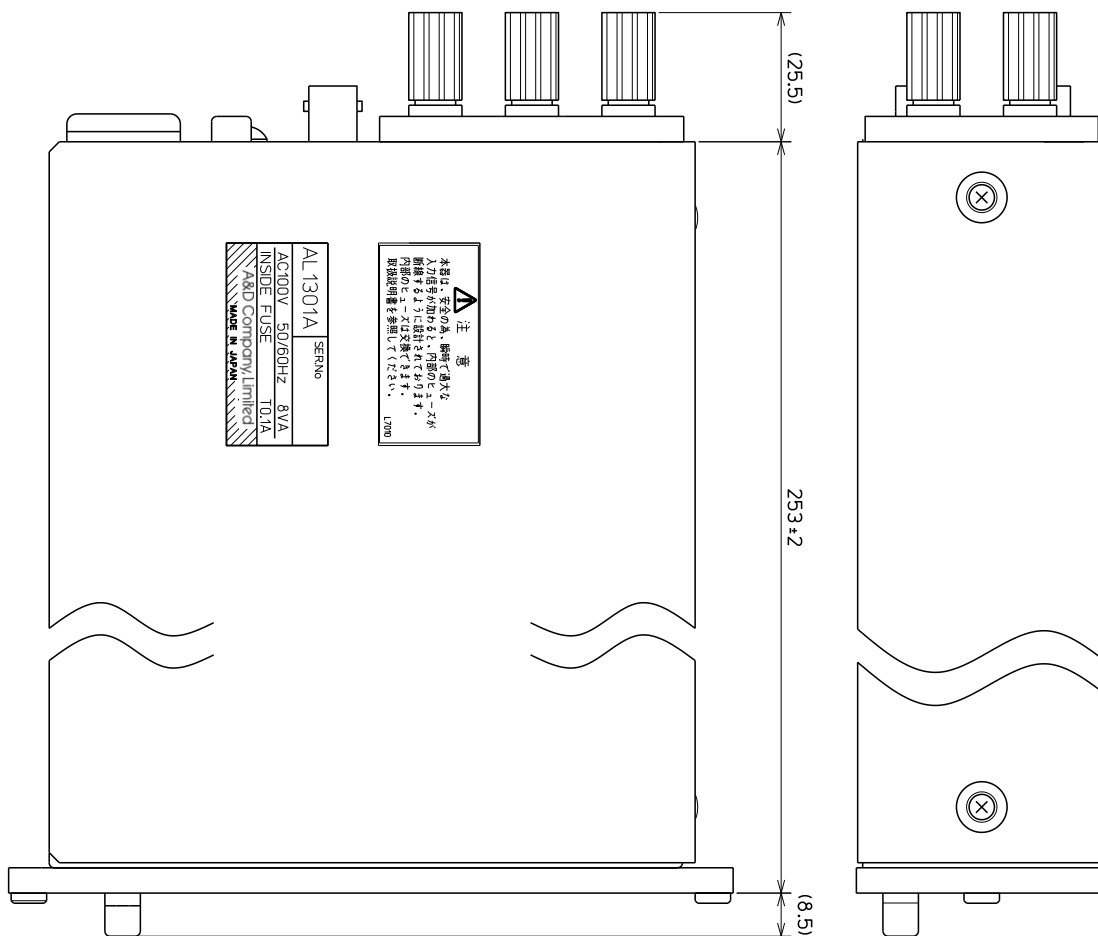
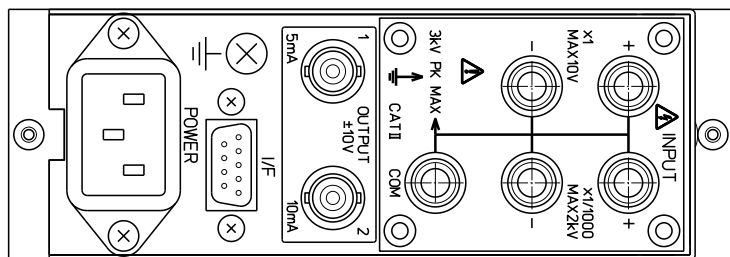

To Ensure Prolonged Use

A&D Company,Limited.

Thank you for purchasing an A&D Company,Limited. product.

To ensure prolonged use of the product that you have purchased, we offer the following lineup of maintenance services.

1. **Warranty Period**

The warranty period for this product is one year from the date of purchase. In case of a failure, the product will be repaired free of charge (only if the failure is ascribable to the responsibility of A&D).

2. **Disclaimers**

We take no responsibility for any damages caused by the following reasons;

- (1) Consequential damages and production compensation caused by any accidents of our product;
 - (2) Damages of our product generated by other companies' equipments and their construction;
 - (3) When operation, proper maintenance, and regular inspection are not done;
 - (4) Troubles which are apparently not attributable to our company or those that cannot be decided clearly whether our company is responsible for those troubles;
 - (5) Exhaustion of consumptions and repair parts;
 - (6) Troubles attributed to third party's conflicts;
 - (7) Troubles caused by a force majeure such as natural disasters
-
-

Address inquiries to:

- (1) This manual may not be reproduced to any form in whole or in part.
- (2) Then contents in this manual may be updated without prior notice.

AL1301A
Operation Manual (1WMPD4003179)

First Edition: July 2015

A&D Company, Limited