

LC-4204 Series

SINGLE POINT BEAM LOAD CELL

SET-UP MANUAL

set-up-LC-4204-v.1.a 89.09.20 OYM

SINGLE POINT BEAM LOAD CELL

MODEL: LC-4204-K300
LC-4204-K600

1. INTRODUCTION

- (1) The LC4204 series is a high precision load cell designed for use with platform scales, and hopper scales.
- (2) Because the LC4204 series features output with minimum deviations between each product, it can be used for single-point or multi-point applications.
- (3) Optimum performance of the LC4204 series is achieved through appropriate installation and operation.

2. INSTALLING ON THE BASE BOARD

- (1) Base board

The base board should be rigid to prevent it from slanting or curving under normal operations. Note that a slanted or curved base board will adversely affect the load cell and inhibit correct measurements.

- (2) Mounting surface

The load cell's mounting surface should have surface finish of 100S (JIS*) or more.

JIS = Japan Industrial Standard

- (3) Fixing Bolts

Use four M12 hexagon socket head bolts (tensile strength Class 12.9 - JIS or equivalent) or four high-tension hexagon head bolts to mount the load cell on the base board. Tighten bolts with a clamping torque of 800 kgf-cm.

- (4) Attaching method

Tighten the bolts in the diagonal order while holding the cable side of the load cell. Adjust the spacer so that the load cell clears the base board by 5mm or more. (See Figures 1 and 2.) Be sure to remove all dirt and dust from the mounting surface at this time.

Note: Be careful not to confuse the top and bottom sides of the load cell when installing it.

Single-Point Load Cell Applicaton

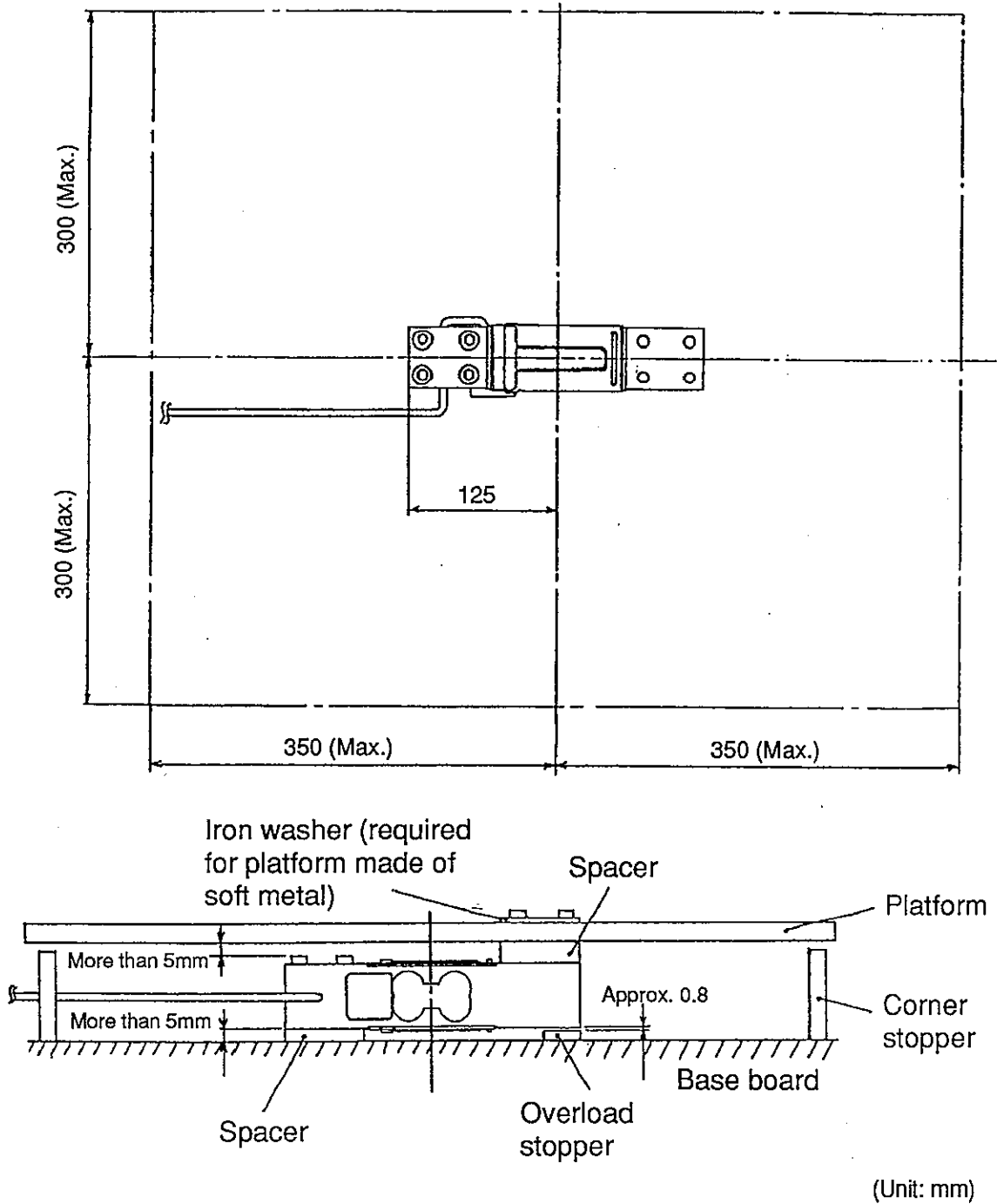

Bolt diameter	Strength class	Clamping torque
M12	12.9 or more	800 kgf-cm

The surface finish of the load cell mounting surface should be 100S (JIS) or more.

Figure 1

3. ATTACHING THE PLATFORM

(1) Tare weight

When the overall tare weight of the LC4204 is within 20% of the rated capacity, no problems will occur. The tare weight should be as small as possible to prolong the service life and excellent performance of the load cell. However, it is not necessary to be too strict about the total load.

Note: The tare weight mentioned above includes the platform or equivalent (i.e., hopper) and related parts. but not the container of the object to be measured.

(2) Mounting surface

The load cell's mounting surface should have a surface finish of 100S (JIS) or more.

(3) Fixing bolts

Use four M12 hexagon socket head bolts with a tensile strength of Class 12.9 or equivalent or high-tensile hexagon head bolts to mount the load cell on the base board. Tighten the bolts with a clamping torque of 800 kgf-cm.

For a platform made of aluminum or soft metal, use iron washers to distribute the compressive load of the bolts.

(4) Attaching method

When tightening the bolts, be careful not to apply excessive force (torsion or lateral load) to the load cell. Tighten them in the diagonal order and adjust the spacer so that load cell clears the base board by 5mm or more.

(5) Precautions on multiple-point use

When using two or more load cells in combination, mounting the platform directly to the load cell will cause mutual interference between each load cell. Therefore, use a device to avoid such interference. For example, use a device to insert rubber pads or steel ball bearing between the load cells and the platform. (See Figure 2.)

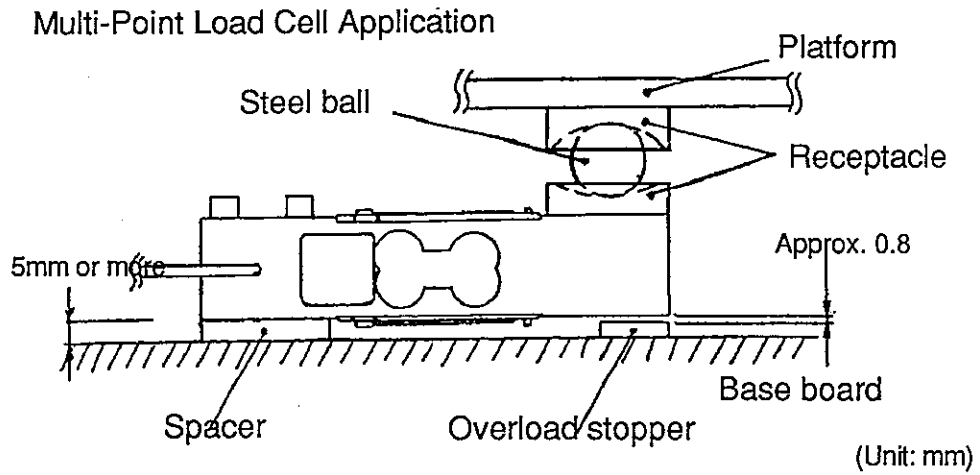

Bolt diameter	Strength class	Clamping torque
M12	12.9 or more	800 kgf-cm

The surface finish of the load cell mounting surface should be 100S (JIS) or more.

Cable color

Red	Excitation +
White	Excitation -
Green	Signal +
Blue	Signal -
Yellow	Shield

Figure 2

(6) Precautions on designing a platform

The allowable dimensions of the platform for a single-point load cell are shown in the Figure 1. Use a platform made of a very rigid material.

4. PRECAUTIONS ON OVERLOAD

(1) Mechanical strength of load cell.

When a load is applied to the center of the load cell, the allowable limit of the load is 200% of the rated capacity. however, the allowable load at the corner should be 100% of the rated capacity.

Repeated overloading exceeding the allowable limit may shortens the service life of the load cell, and even destroy it in extreme cases. This also applies to the lateral load.

The actual load at the corner should be less than 50% of the rated capacity.

(2) Overload stopper

If excessive shock force is applied by accidentally dropping the object to be weighed, the load will exceed the allowable limit. Therefore, be sure to attach the overload stopper to the load cell. (See Figure 3.)

Attaching the Stopper

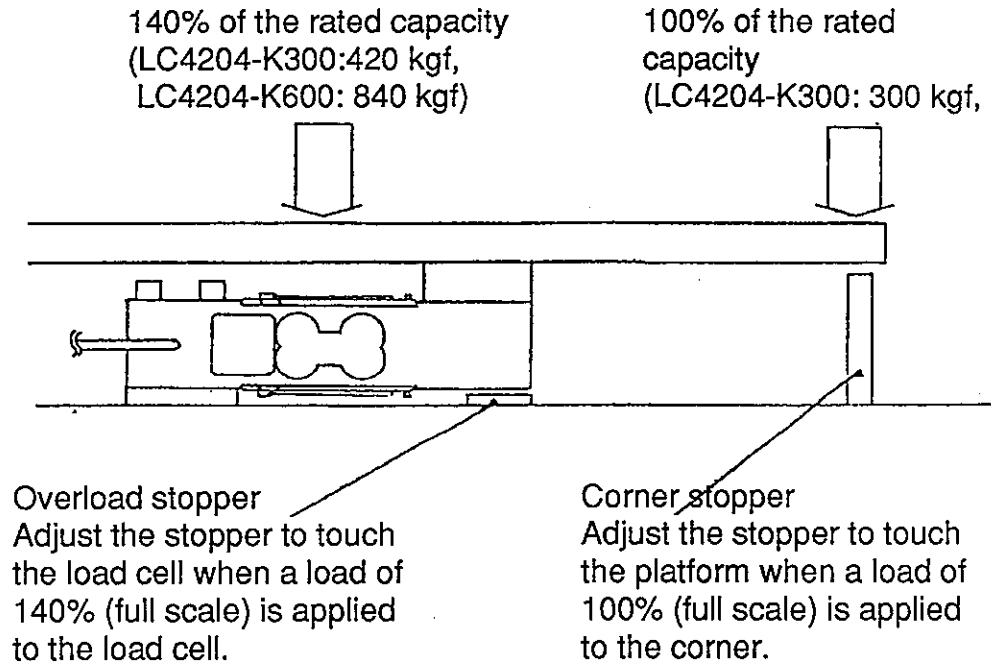

Figure 3

Adjust the overload stopper to touch the platform when applying a tare weight (less than 20% of the rated capacity) plus 140% of the rated capacity. Although there may be some differences due to base board rigidity, the clearance between the load cell and the stopper under no load is approximately 0.8mm when a load of 140% of the rated capacity is applied to the center of the platform and the load cell touches the stopper.

(3) Corner stoppers

Even when the overload stopper is properly adjusted, if excessive shock or an overload is applied to the corners, it may exceed the allowable limit due to the flexibility of the base board. Therefore, attach corner stoppers at the corners of the platform at approximately 100% of the rated capacity. (See Figure 3.)

The clearance between the load cell and corner stoppers varies depending on the platform form or material. Therefore, adjust the corner stoppers according to the actual setup conditions.

(4) In case shock is likely to occur

If excessive shock force is likely to occur, overlay the platform with a shock absorber to reduce the shock applied to the load cell.

5. OVERALL FUNCTION TEST

- (1) To make full use of load cell performance, pay attention to the following points.
 - ①A stable power supply for the load cell
 - ②A stable weighing indicator (No. of digits matching the specified accuracy is needed).
 - ③Installation site subject to minimum changes in temperature
 - ④Installation site where the load cell platform remains horizontal
 - ⑤Installation site free of external vibration or noise

- (2) After installing the load cell,execute the initial test as follows.
 - ①Warm up the machine for approximately 10 minutes.
 - ②Apply a load 100 to 150% of the rated capacity 3 to 5 times. Then monitor the loading time and zero point to ensure proper operation.
 - ③After applying a load three times to ensure proper operation, the specified accuracy can be obtained.

6. MAINTENANCE

- (1) Remove all dirt and dust from the load cell, and always it in a clean environment.

- (2) Clean the section covered with rubber without pressing hard.

- (3) Periodically inspect the overload stopper and corner stoppers.