

Simplified Instruction Manual

- All rights reserved. No part of this manual may be reprinted or copied without the prior written permission of A&D.
- The specifications and other information contained in this manual are subject to change without notice in order to make improvements.
- Every precaution has been taken in the preparation of this manual. Nevertheless, A&D assumes no responsibility for errors or omissions. If you discover any problems with this manual, please notify A&D.
- A&D Company, Limited shall not be liable for special, indirect, incidental, or consequential damages, loss of profits or production or commercial loss in any way connected with the products, whether such claim is based in contract, warranty, negligence, or strict liability.

© 2023 A&D Company, Limited



1WMPD4004632C

Telephone: [81] (3) 5391-6132 Fax: [81] (3) 5391-1566

Detailed instruction manual

This manual provides simplified precautions and operating instructions for AD-4411. For further information about the AD-4411, please refer to the "AD-4411 Instruction Manual" which is available for download from the A&D website (<https://www.aandd.jp>).

Introduction

The AD-4411 is a weighing indicator that can convert signals from strain gauge load cells and connect them to an Ethernet-based field network. It contributes to an efficient system by connecting weighing instruments to industrial control systems in plants and factories.

- Daisy-chain connection is possible without a switching hub, thanks to two communication ports.
- 7-segment green LED display with a character height of 10mm and display resolution of ±999999.
- High-speed AD conversion of 1200 times/second and digital filter enable high speed and accuracy weighing.
- DIN96x48 panel mount type with IP65 protection on the front panel.
- PC can update the settings via USB port.

Safety precaution

If the equipment is used in a manner not specified by the manufacturer, the protection provided by the equipment may be impaired.

Read the following precautions carefully before using the indicator for safe and correct usage.

WARNING

- Provide an external safety circuit to the indicator so that the safety of the whole system can be secured even if errors occur in the external power supply or the indicator.
- This indicator must be used indoors. Do not use the indicator in the following environment:
 - where the temperature and the humidity exceed the specifications
 - where corrosive gases or flammable gases exist
 - where the indicator gets wet with oil, chemicals, or water
 - where the indicator is exposed to direct sunlight
- Turn off all the external power supplies used in the system before installing or removing the indicator.
- Turn off all the external power supplies used in the system before wiring.
- Be sure to ground the indicator.

CAUTION

- Do not clamp control wires or communication cables with power lines, or do not place them close to power lines.
- Place the load cell cable sufficiently away from high frequency circuits such as high voltage power lines and inverter load circuit.
- When the front cover have dirt, wipe them with wet soft cloth. Do not use organic solvent such like benzene, thinner and alcohol. Doing so may result in deformation or discoloration of the unit.
- Suitable for use at pollution degree of 2 or less.
- Use within an altitude of 0 to 2000m
- To an external connection port connect the circuit separated from a dangerous voltage by a double/reinforced insulation.

Part names

Front panel

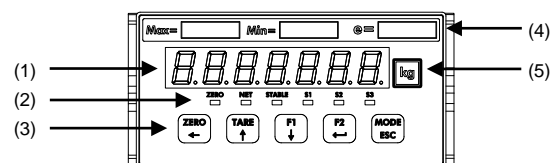

No.	Name	Description
(1)	Main display	Displays measured value or various settings.
(2)	ZERO status	The LED is ON when the measured value is within 1/4 the minimum division.
	NET status	The LED is ON when the net value is displayed.
	STABLE status	The LED is ON when the measured value is stable.
	S1 / S2 / S3 status	The LED is ON when the S1 / S2 / S3 status ON condition status (FncF07 / 08 / 09) is met.
(3)	[ZERO/←] key	Zeros the gross value. Moves the flashing digit to the left when not in measurement mode.
	[TARE/↑] key	Performs tare. Increases the flashing digit by one when not in measurement mode.
	[F1/↓] key	Performs the function set for the F1 key function (FncF05). Decreases the flashing digit by one when not in measurement mode.
	[F2/↔] key	Performs the function set for the F2 key function (FncF06). Updates the setting value entered when not in measurement mode.
(4)	[MODE/ESC] key	Changes the operation mode. Cancels the setting value entered when not in measurement mode.
	Capacity label	Attach the included capacity label, if necessary.
(5)	Unit label	Attach the included unit label, if necessary.

Rear panel

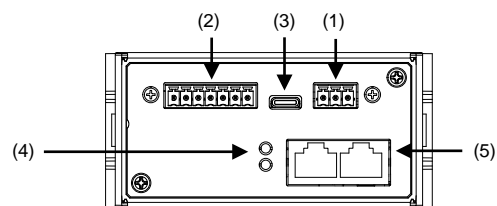

No.	Name	Description
(1)	DC power input terminals	Terminals for connection of a DC24V power supply.
(2)	Load cell input terminals	Terminals for connection of load cells.
(3)	USB connector	Connector for connection with setting PC. (Type-C)
(4)	Field network status LEDs	Notifies field network status.
(5)	Field network connector	Connector for connection of PLC via field network. Dual ports can be used for daisy chain wiring (RJ-45).

Accessories

Waterproof packing, Panel mount bracket x2, Capacity label, Unit label, Power connector, Load cell connector.

Mounting to control panel

Insert the waterproof packing around the Unit, and insert the Unit through the front of the panel.

Insert the left and right mounting brackets into the case grooves and push until they reach the panel.

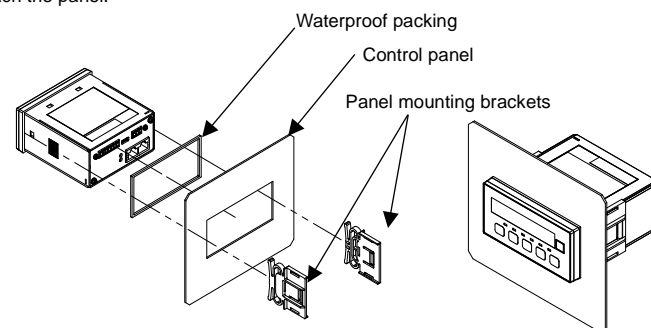

Connection to power supply and connection to load cell

Attach the accessory power connector and wire as shown in the figure below.

Applicable wire

Item	Specifications
Wire size	0.14 to 1.5 mm ² (AWG 26 to 16)
Wire strip length	7 mm
Tightening torque	0.22 to 0.25 Nm

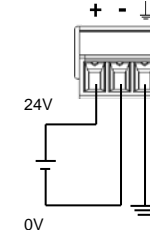

In the case of the 4-wire connection type, attach the accessory load cell connector and wire as shown below. Change the load cell connection type (CALF17) in the calibration function to 0: 4-wire type (default value = 1: 6-wire type).

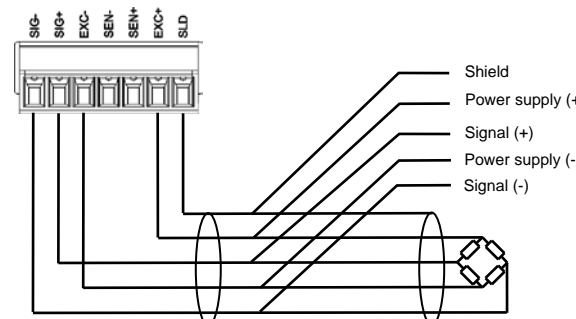

6-wire connection

Set load cell connection type (CALF17) to 1: 6 wire type (Default).

When you connect the load cells in parallel, use a summing box. Attach the accessory load cell connector and wire as shown below.

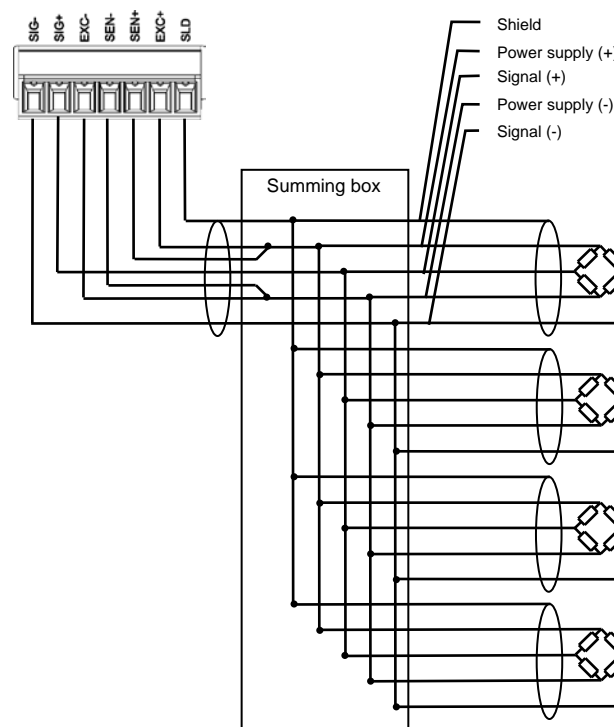

Calibration

Calibrate the AD-4411 to properly convert the signal from the load cell to a load value. Please prepare a calibration weight.

After Power-On, press the [MODE/ESC] key more than 3s.

Press the [F1/↓] key twice.

Press the [F2/↔] key.

Press the [F1/↓] key.

Actual load calibration
Press the [F2/↔] key.

Press the [F2/↔] key.

The current load cell input signal (mV/V) will be displayed. Press the [F2/↔] key to execute Zero calibration.

If Zero calibration is successful, "PASS" will be displayed, and zero calibration will be completed. Press the [F2/↔] key.

Press the [F2/↔] key.

Set a calibration weight value by the following key operations.

[ZERO/←] key: Moves the flashing digit to the left.
[TARE/↑] key: Increases the flashing digit by one.
[F1/↓] key: Decreases the flashing digit by one.
[F2/↔] key: Confirm the setting value.

The current load cell input signal (mV/V) will be displayed. Place the calibration weight or apply a load on the load cell. Press the [F2/↔] to execute Span calibration.

If span calibration is successful, "PASS" will be displayed, and span calibration will be completed. Press the [MODE/ESC] key four times to return to the measurement mode.

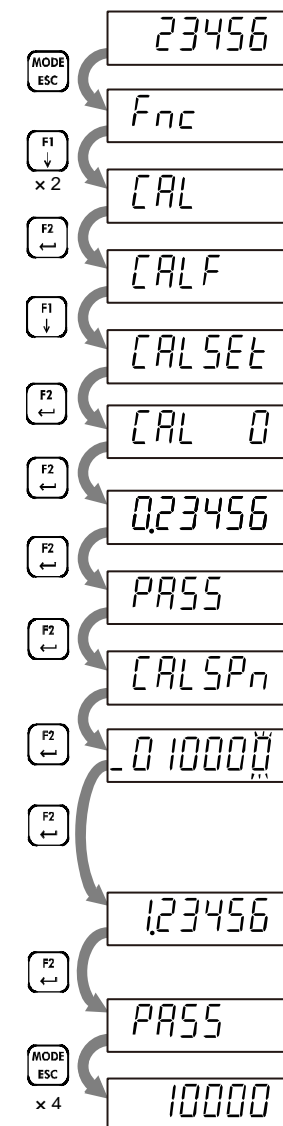

Operation mode

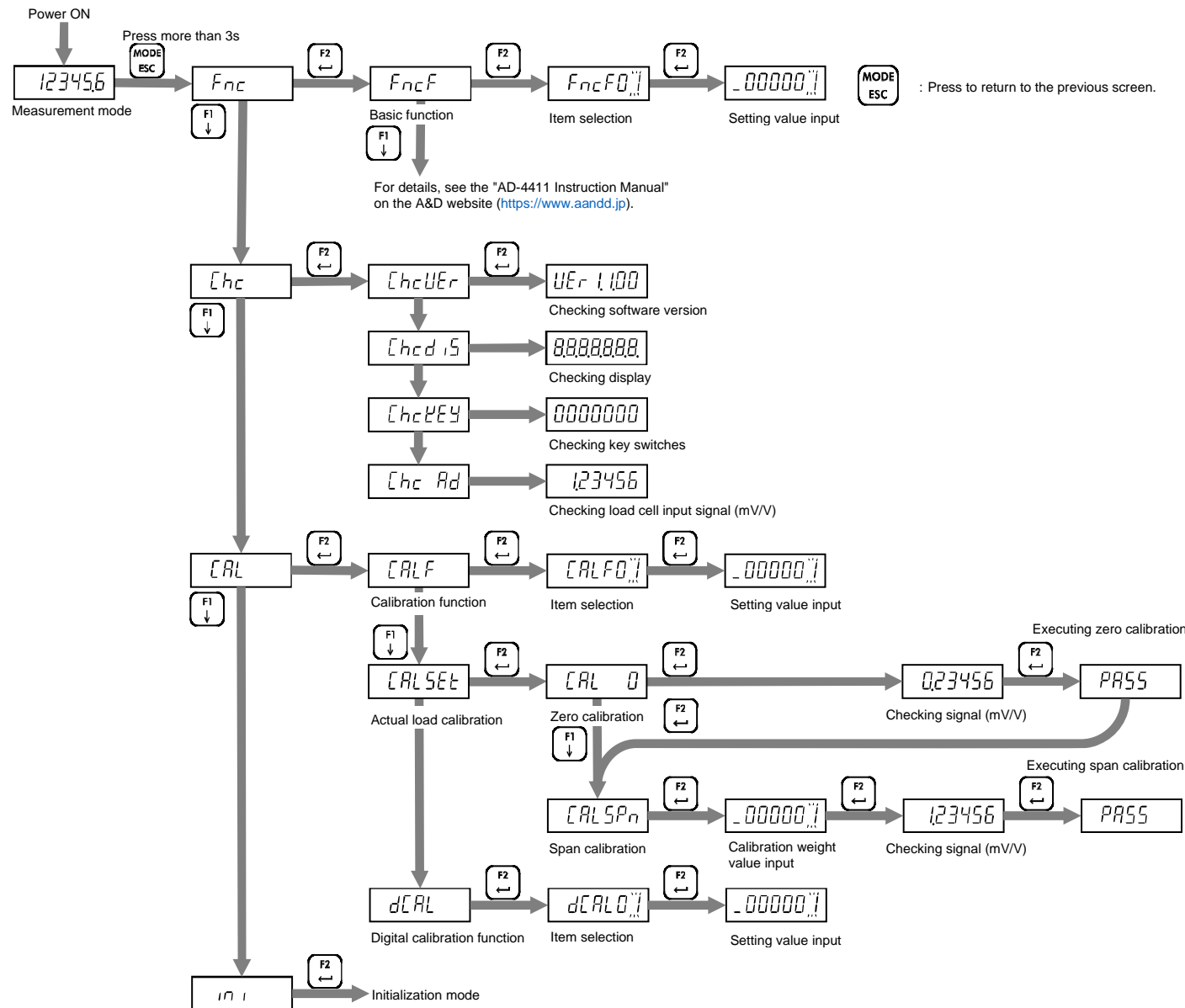

Function list

Calibration function list

CALF	Setting item	Setting value	Default
01	Unit	0: None / 1: g / 2: kg / 3: t	2
02	Decimal point position	0: 0 (No decimal point) / 1: 0.0 / 2: 0.00 / 3: 0.000 / 4: 0.0000 / 5: 0.00000	0
03	Minimum division d	1: 1 d / 2: 2 d / 3: 5 d / 4: 10 d / 5: 20 d / 6: 50 d	1
04	Maximum capacity	1 to 999999	999999
05	Zero setting range	0 to 100 %	100
06	Zero tracking time	0.0 to 5.0 s	0.0
07	Zero tracking width	0: Disable / 1: 0.5 d / 2: 1.0 d / 3: 1.5 d / 4: 2.0 d / 5: 2.5 d / 6: 3.0 d / 7: 3.5 d / 8: 4.0 d / 9: 4.5 d	0
08	Stability detection time	0.0 to 9.9 s	1.0
09	Stability detection width	0 to 100 d	2
10	Zero-setting when unstable	0: Disable / 1: Enable	1
11	Taring when unstable	0: Disable / 1: Enable	1
12	Taring when the gross is negative	0: Disable / 1: Enable	1
13	Zero clear	0: Disable / 1: Enable	1
14	Power-on zero	0: Disable / 1: Enable	0
15	Condition of negative overload	0: Gross < -(Maximum capacity + 8d) / 1: Gross < -19d	0
16	NTEP	0: Disable / 1: Enable	0
17	Load cell connection type	0: 4-wire type / 1: 6-wire type	1

Digital calibration function list

dCAL	Setting item	Setting value	Default
01	Load cell input signal at Zero Calibration	-7.00000 to 7.00000 mV/V	0.00000
02	Load cell input signal (at Span Calibration - at Zero Calibration)	0.00001 to 7.00000 mV/V	2.00000
03	Weight value at Span Calibration	1 to 999999	20000

Basic function list

FncF	Setting item	Setting value	Default
01	Locking [ZERO/←] key	0: Disable / 1: Enable	0
02	Locking [TARE/↑] key	0: Disable / 1: Enable	0
03	Locking [F1/↓] key	0: Disable / 1: Enable	0
04	Locking [F2/←] key	0: Disable / 1: Enable	0
05	Function of [F1/↓] key	0: None / 1: Tare clear / 2: Zero clear / 3: Gross / net display selection / 4: High-resolution display selection	0
06	Function of [F2/←] key	0: None / 1: Hi / 2: OK / 3: Lo /	0
07	Condition to turn S1 status ON	0: None / 1: Hi / 2: OK / 3: Lo /	0
08	Condition to turn S2 status ON	4: Zero setting error / 5: Taring error /	0
09	Condition to turn S3 status ON	6: High resolution display	0
10	Digital filter cut-off frequency [Hz]	0: 273.0 12: 20.0 24: 2.8 36: 0.40 1: 120.0 13: 17.0 25: 2.4 37: 0.34 2: 100.0 14: 14.0 26: 2.0 38: 0.28 3: 84.0 15: 12.0 27: 1.7 39: 0.24 4: 70.0 16: 10.0 28: 1.4 40: 0.20 5: 68.0 17: 8.4 29: 1.2 41: 0.17 6: 56.0 18: 7.0 30: 1.0 42: 0.14 7: 48.0 19: 6.8 31: 0.84 43: 0.12 8: 40.0 20: 5.6 32: 0.70 44: 0.10 9: 34.0 21: 4.8 33: 0.68 45: 0.08 10: 28.0 22: 4.0 34: 0.56 46: 0.07 11: 24.0 23: 3.4 35: 0.48	30
11	Upper limit value	-999999 to 999999	10
12	Lower limit value	-999999 to 999999	-10
13	Comparison target for Upper limit value / Lower limit value	1: Gross / 2: Net	1

For functions other than those listed above, see the "AD-4411 Instruction Manual" on the A&D website (<https://www.aandd.jp>).

Specifications

Dimension	96(W) x 48(H) x 98.5(D) mm
Installation method	Panel mount
Operating temperature and humidity range	-10°C to +40°C Less than 85%RH, non-condensing
IP rating	(When the indicator is installed to the control panel) Front panel: IP65. Inside the panel: IP2X
Power supply	DC24V -15% to +10%, 4.5W max.
Load cell input	DC5V ±5% 90 mA
Excitation voltage	Up to six 350 Ω load cells can be connected in parallel. 6-wire type with remote sensing
Signal input range	-7.0 mV/V to +7.0 mV/V
minimum input sensitivity	0.15 μV/d or more (d=minimum division)
Nonlinearity	0.005% of F.S. max.
Temperature coefficient	Zero drift: ±0.02 μV/°C typ. ±0.1 μV/°C max. Span drift: ±3 ppm/°C typ. ±15 ppm/°C max.
Sampling rate	1200 times / second
Display	7-digit LED (green) with a character height of 10 mm LED (red) x 6
Main display	7-digit LED (green) with a character height of 10 mm
Status display	LED (red) x 6
Unit	Attach a label of g / kg / t
Key switches	x 5
External interface	
AD-4411-EIP	EtherNet/IP
AD-4411-PRT	PROFINET
AD-4411-ECT	EtherCAT
USB	Type-C connector, USB 2.0 (Full-speed)

External dimension

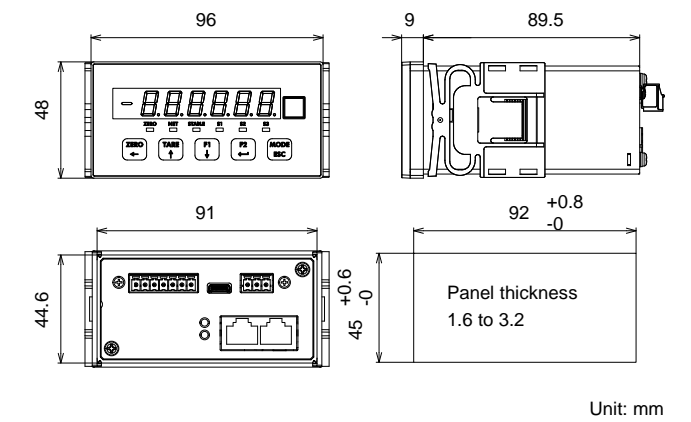

FCC - Supplier's Declaration of Conformity
47 CFR § 2.1077 Compliance Information
Model: AD-4411
Responsible Party: A&D ENGINEERING, INC.
Address: 4622 Runway Boulevard Ann Arbor, MI 48108, U.S.A.
Tel: [1] (888) 726-5931
This device complies with part 15 of the FCC Rules. Operation is subject to the following two conditions: (1) This device may not cause harmful interference, and (2) this device must accept any interference received, including interference that may cause undesired operation.