

HV-CWP series

HW-CWP series

INSTRUCTION MANUAL

Waterproof Digital Platform Scale

**HV-15KCWP
HV-60KCWP
HV-200KCWP**



**HW-10KCWP
HW-60KCWP
HW-100KCWP
HW-200KCWP**

AND

A&D Company, Limited

This Manual and Marks

All safety messages are identified by the following, "WARNING" or "CAUTION", of ANSI Z535.4 (American National Standard Institute: Product Safety Signs and Labels). The meanings are as follows:

 WARNING	A potentially hazardous situation which, if not avoided, could result in death or serious injury.
 CAUTION	A potentially hazardous situation which, if not avoided, may result in minor or moderate injury.



This is a hazard alert mark.

© 2019 A&D Company Ltd. All rights reserved.

No part of this publication may be reproduced, transmitted, transcribed, or translated into any language in any form by any means without the written permission of A&D Company Ltd.

The contents of this manual and the specifications of the instrument covered by this manual are subject to change for improvement without notice.

Windows, Word and Excel are registered trademarks of the Microsoft Corporation.



Contents

Contents	1
1. Compliance	3
1.1. Compliance with FCC rules	3
1.2. Classification of Protection Provided by Enclosures	3
2. Outline and Features	4
3. Unpacking	5
4. Cautions	6
4.1. Precautions for Installing the Scale	6
4.2. Precautions for Operating the Scale	6
4.3. Precautions for Storing the Scale	6
5. Installing the Scale	7
5.1. Setting up the Scale	7
5.2. Removing the Pole	8
5.3. Grounding the Scale	9
6. Part Names and Functions	10
6.1. Display and Symbols	11
6.2. Keys	14
7. Basic Operation	15
7.1. Turning the Scale ON/OFF and Weighing	15
7.2. Power on Zero Function and Power on Tare Function	15
7.3. Tare Function	16
7.3.1. How to Weigh a Tare Weight	16
7.3.2. How to Input Value of a Tare Weight with Numerical Keys (Preset Tare)	16
7.4. Switching the Mode	17
8. Counting Mode	18
8.1. Storing a Unit Mass	18
8.2. Counting the Number of Articles	19
9. Accumulation Function	20
10. Comparator	22
10.1. Setting a Mode and Method	23
10.2. Comparison and Formula	24
10.3. Setting Threshold Values (of Limits and Ranks)	26
10.4. Buzzer Setting	27
11. Auto-tare Function	28
12. Calibration	29
12.1. Calibration Procedure	29
12.2. Calibration Using the Weight	29

- 12.3. Setting the Gravity Acceleration..... 31
- 13. Function 32
 - 13.1. Parameter Setting Procedure 32
 - 13.2. Parameter List 33
 - 13.3. Initializing Function Settings 36
- 14. Options 37
 - 14.1. Options List..... 37
 - 14.2. Installing the Communication Option 37
 - 14.3. HVW-02BCWP USB Interface..... 38
 - 14.3.1. Procedure for Using the USB Interface 39
 - 14.3.2. Example of Using the USB Interface 39
 - 14.4. HVW-03CWP RS-232C Interface 41
 - 14.5. HVW-04CWP Comparator Relay Output / Buzzer..... 42
 - 14.6. Communication Format..... 43
 - 14.7. Using UFC (Universal Flex Coms) Function 51
- 15. ID Number and GMP, GLP 55
 - 15.1. Setting the ID Number 55
 - 15.2. GMP, GLP Report 56
- 16. Maintenance..... 61
 - 16.1. Repair 61
 - 16.2. Check Points Before Calling Maintenance Service 61
- 17. Specifications 62



1. Compliance

1.1. Compliance with FCC rules

- Please note that this equipment generates, uses and can radiate radio frequency energy. This equipment has been tested and has been found to comply with the limits of a Class A computing device pursuant to Subpart J of Part 15 of FCC rules. These rules are designed to provide reasonable protection against interference when this equipment is operated in a commercial environment. If this unit is operated in a residential area, it might cause some interference and under these circumstances the user would be required to take, at his own expense, whatever measures are necessary to eliminate the interference.

(FCC = Federal Communications Commission in the U.S.A.)

1.2. Classification of Protection Provided by Enclosures

- This equipment is designed to comply with the IP Code of IEC 529.

The "IP-65" code is explained as follows:

"IP" International Protection.

"6" Against ingress of solid foreign objects.

Dust-tight. No ingress of dust.

"5" Against ingress of water

Protected against water jets (no powerful jets).

Water projected in jets against the enclosure from any direction shall have no harmful effects.



2. Outline and Features

- These scales are designed to comply with IP-65 of IEC 529.
- These scales are equipped with a weighing pan made of stainless steel (SUS304).
- The HV-CWP series are platform scales with 1/3000 resolution, and have a triple weighing range function to select the weighing range. The readability automatically switches to smaller interval when a light object is weighed or larger interval when a heavy object is weighed, depending on the weight of the object (multi-interval).
- The HW-CWP series is made up of platform scales with 1/10000 resolution.
- The scales use a backlit liquid crystal display to enable viewing in dim light.
- Using the optional RS-232C serial interface or USB interface, data can be output to a printer. Also, the weighing value can be output, the scale can be controlled or the setting value can be set by a command from a personal computer.
- The counting mode converts the total mass value (total weight) of articles to a count when each article has the same mass value.
- The scales have an accumulation function with a maximum of 6 digits, which can accumulate up to 999 times (The number of times weighed and the total mass value of that can be stored in the scale).
- The comparator function compares the displayed weighing value against preset limit values and displays the result. The comparison result can be output if the optional HVW-04CWP is installed on the scale.
- The following parameters are stored in the scale even if the power is turned off.

Unit mass of counting mode
Total count and total mass of accumulation function
Preset limit values of comparator function
Calibration data
Parameters of the function table

- Multi-interval :
The readability (scale interval or "individual or "division") is automatically switched depending on the weight of an object to be measured.

Example : The HV-60KCWP with 60kg weighing capacity and 0.005kg, 0.01kg or 0.02kg readability. The readability is automatically switched when the small, medium or large range is exceeded.

Point : When a lighter object is weighed, the readability becomes finer. When a heavier object is weighed, the readability becomes coarser.

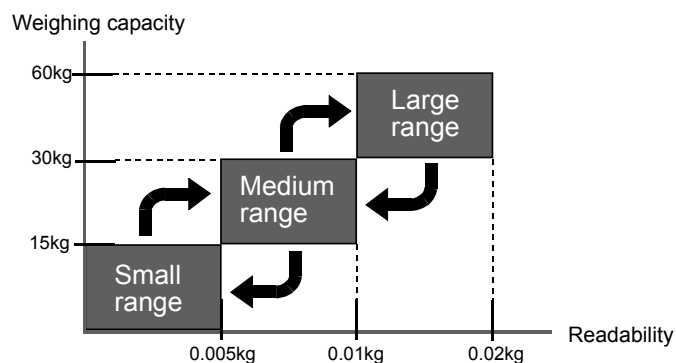



3. Unpacking

HV-15KCWP
HW-10KCWP

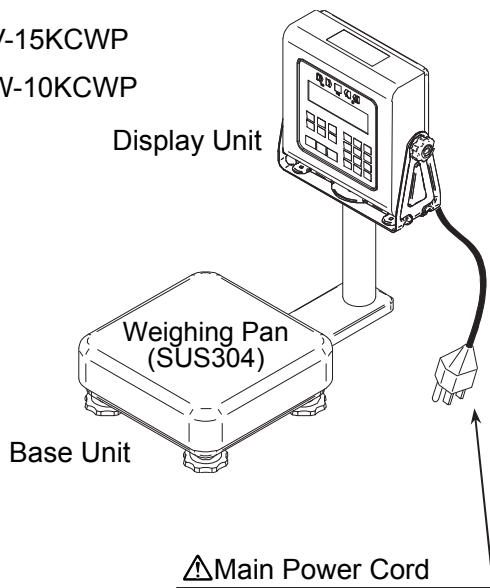

HV-60KCWP
HW-60KCWP

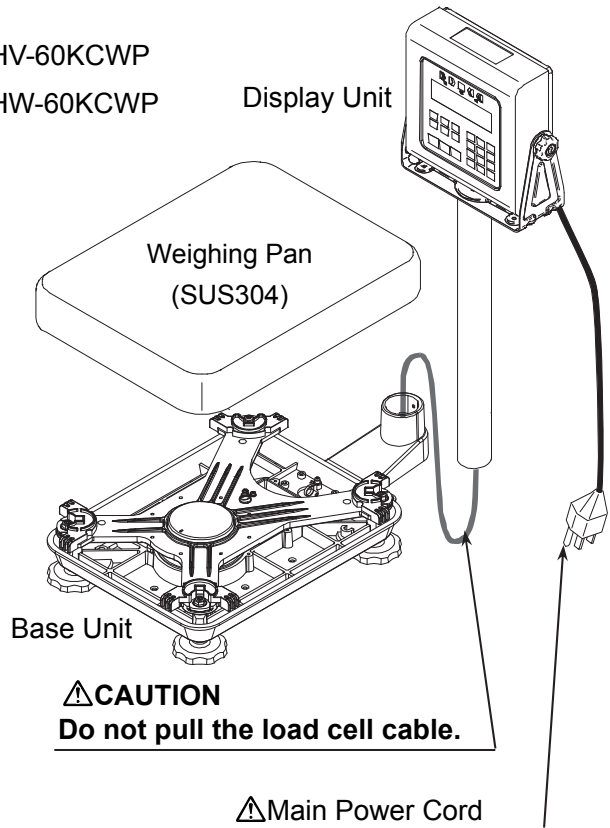

HV-200KCWP
HW-100KCWP
HW-200KCWP

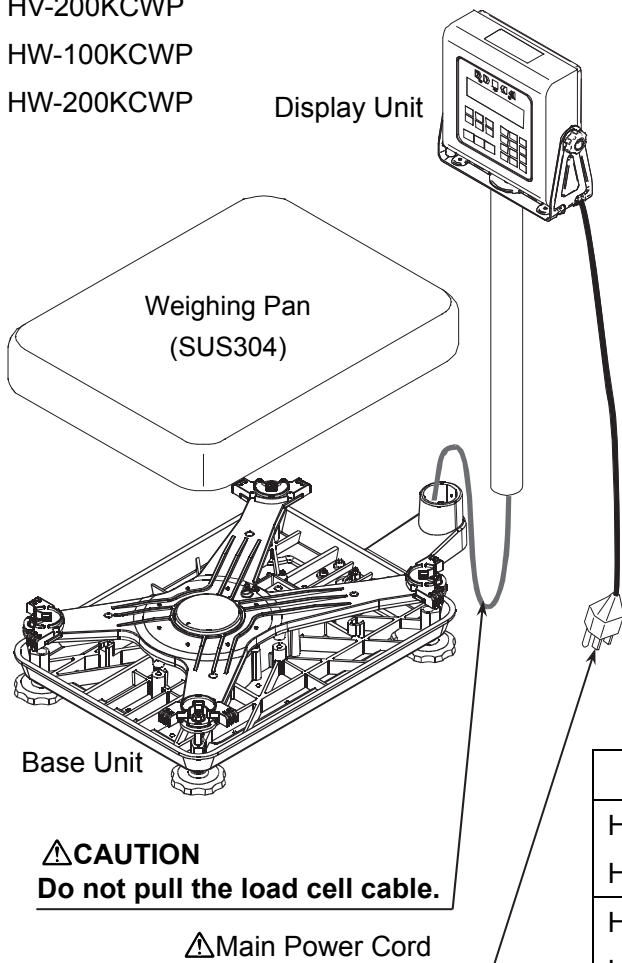

⚠ Main Power
Please confirm that the local voltage and the receptacle type are correct for your scale.

Accessories

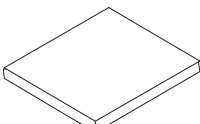
-  3mm Hex Wrench
-  Instruction Manual

Models	Accessories
HV-15KCWP, HW-10KCWP	Instruction Manual
HV-60KCWP, HW-60KCWP, HW-100KCWP, HV-200KCWP, HW-200KCWP	3mm Hex Wrench Instruction Manual



4. Cautions

4.1. Precautions for Installing the Scale

WARNING

- Ground the scale, so that the user will not be subjected to an electric shock.**
 - Do not handle the main power cord with wet hands.**
 - The AC plug is not water-resistant. Install it in an area where it does not get wet.**
 - Do not install the scale where there is flammable or corrosive gas present.**
 - Do not pull, fold or arrange cables forcibly.**
 - The scale is heavy, so handle it with care when transporting.**
- The scale must be transported by holding the base as holding the pole may cause the scale to fall.**

Consider the following conditions to get the most from your scale.

- Install the scale on a solid and level surface where the temperature and relative humidity is stable, there is no draft and a stable power source is available.
- Do not install the scale on a soft floor or where there is vibration.
- Do not install the scale near heaters or air conditioners.
- Do not install the scale in direct sunlight.
- Do not install the scale near equipment that produces strong magnetic fields.
- Do not install the scale where static electricity is likely to occur. When the relative humidity is lower than 45%R.H., plastic and isolators are apt to be charged with static electricity.
- Do not use an unstable power source.
- Remove the protective film from the weighing pan before use.
- The scale must be used indoors only. Using the scale outdoors may expose the scale to lightning surge beyond its withstand current rating. In such a case, the scale may incur mechanical damages as it cannot withstand lightning energy.

4.2. Precautions for Operating the Scale

- Do not place anything on the weighing pan that exceeds the weighing capacity.
- Do not drop anything on the weighing pan.
- Do not use a sharp instrument such as a pencil or ball-point pen to press the switches. Press the switches gently using only your finger.
- Pressing the **ZERO** key before each weighing to prevent possible error.
- Weighing must not be done with the scale in water.
- Periodically ensure that the weighing value is correct.
- Close the calibration switch cover and the display rear cover to keep waterproof.
- Calibrate the scale when it is initially installed and after it is moved to another location.

4.3. Precautions for Storing the Scale

- Do not disassemble the scale.
- Do not use solvents to clean the scale.
- For best cleaning of the display unit, wipe with a dry lint-free cloth or a lint-free cloth moistened with water and a mild detergent.
- Do not scratch the base unit with a brush.
- Do not use a powerful water jet.



5. Installing the Scale

5.1. Setting up the Scale

The following procedure describes general steps for installing the scale. Some steps may not be required for some models or in some cases.

Step 1 Take the base unit and the pole out of the packing box while being careful not to pull the load cell cable.

Step 2 Put the weighing pan on the base unit. Remove the protective film from the pan before use.

Step 3 While being careful not to harm the load cell cable, insert the pole into the bracket of the base unit, with the excess load cell cable tucked inside the pole. Secure the pole to the bracket with the two provided hex screws using the 3 mm hex wrench.

* This step is not required for HV-15KCWP or HW-10KCWP because the pole and bracket are provided as a combined unit.

Step 4 Decide where to install the scale by considering the descriptions of "4.1. Precautions for Installing the Scale".

Step 5 Level the base unit by adjusting the four leveling feet of the base unit so that the bubble of the spirit level is centered, and then adjust the pole foot beneath the pole to stand on the floor.

Step 6 Ground the scale using the earth terminal in order to prevent electric shock.

⚠ CAUTION

Please confirm that the local voltage and the receptacle type are correct for your scale.

Step 7 Adjust the angle of the display unit using the knobs on the right and left sides.

Step 8 Check the weighing accuracy. If necessary, perform calibration so that the scale can weigh accurately. For calibrating the scale, refer to "12. Calibration".

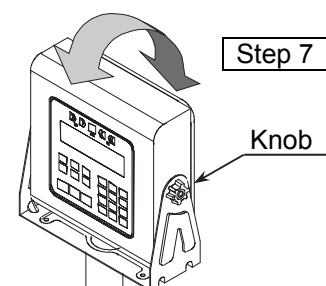
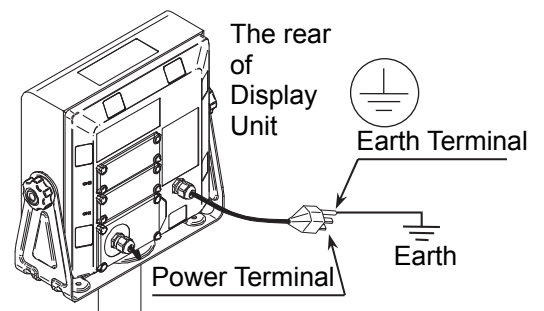
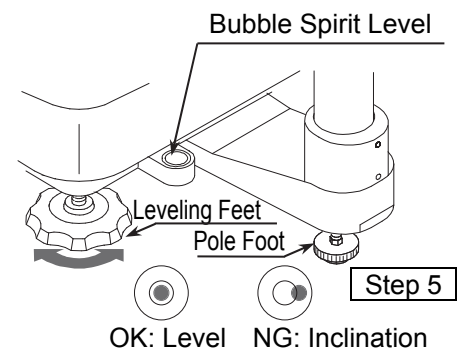
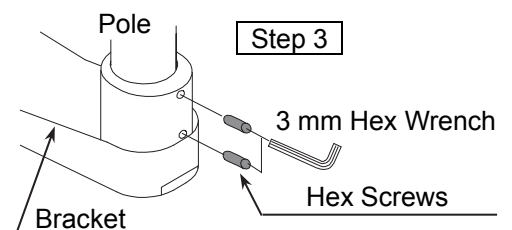
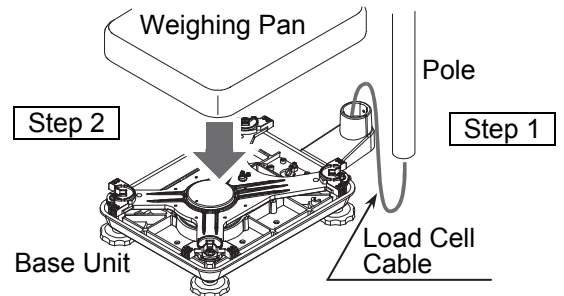

5.2. Removing the Pole

⚠ WARNING

- ❑ Turn off the scale and remove the main power plug from the receptacle before removing the pole.

⚠ CAUTION

- ❑ Do not pull the load cell cable. Do not bend the load cell cable forcibly.
- ❑ Take care that the load cell cable does not touch the weighing pan inside the base unit.
- ❑ Avoid dust, static electricity and high humidity (or condensation) because the inside of the display unit is sensitive to those.

Step 1 Remove the main power plug from the receptacle.

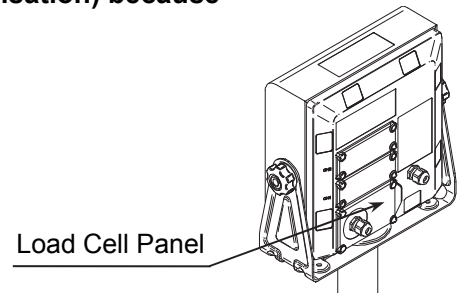

Step 2 Open the load cell panel in the rear of the display unit. Remove the load cell cable connected to the terminal using a flat-head screwdriver.

Red : EXC+
 White : EXC-
 Green : SIG+
 Blue : SIG-
 Yellow : SHIELD

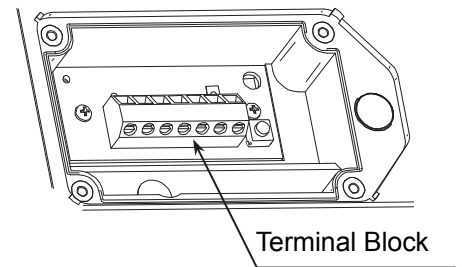

Step 3 Unfasten the two knobs fastening the display and the pole.

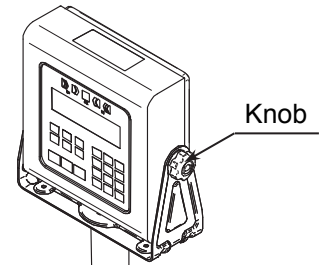

Step 4 Remove the four 3mm screws from the bottom cover of the bracket using a Phillips screwdriver.

Step 5 Carefully remove the load cell cable from the pole. Be careful not to pull the cable forcibly.

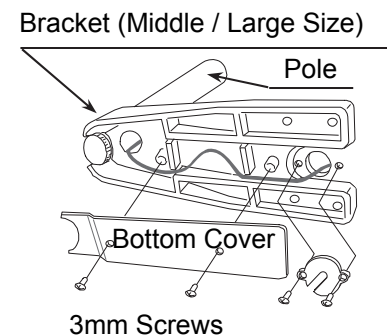

Step 6 Fix the cable so it does not touch to the weighing pan in the base unit.
 If the cable is untied, the straight length of 10K/15K models is approximately 1.5 m, and the straight length of the other models is approximately 2.5 m.

Step 7 To remove the bracket from the base unit, use a hex wrench.

For HV-15KCWP, HV-60KCWP, HW-10KCWP, HW-60KCWP	For HV-200KCWP, HW-100KCWP, HW-200KCWP
5mm Hex Wrench	6mm Hex Wrench

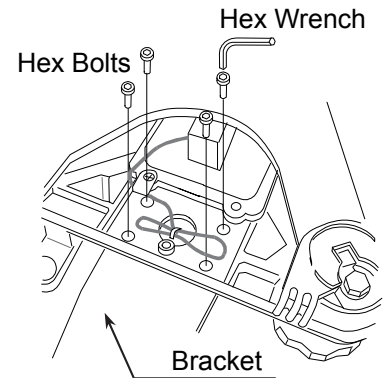

Step 8 Connect the load cell cable to the terminal of the display unit.

Step 9 Close the load cell panel.

Step 10 Check the weighing accuracy.

* The installation example is when the optional indicator holder (AX-043005266) is used after the pole is removed.

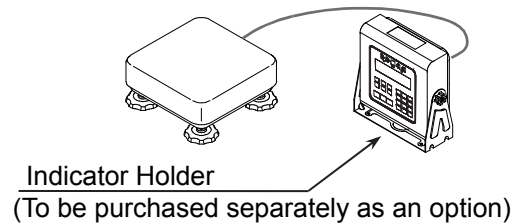

5.3. Grounding the Scale

When using where there may be static electricity, ground the scale.

The grounding method differs depending on the model.

Ground the scale properly according to the model.

Method-A procedure to ground the scale

(HV-15KCWP, HW-10KCWP)

Secure the grounding wire using an M4 screw in the screw hole between the two hexagon bolts on the base unit bottom side (Part "□→").

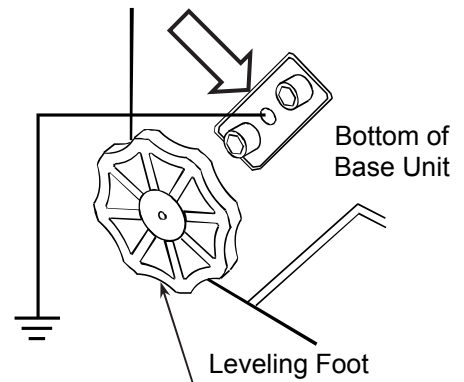

Method-B procedure to ground the scale

(HV-60KCWP, HV-200KCWP,
HW-60KCWP, HW-100KCWP, HW-200KCWP)

Secure the grounding wire together with the screw that secures the bottom cover (Part "□→").

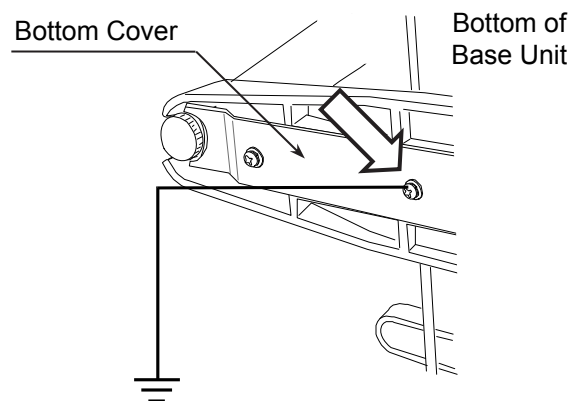



6. Part Names and Functions

HV-15KCWP
HW-10KCWP

HV-60KCWP
HV-200KCWP
HW-60KCWP
HW-100KCWP
HW-200KCWP

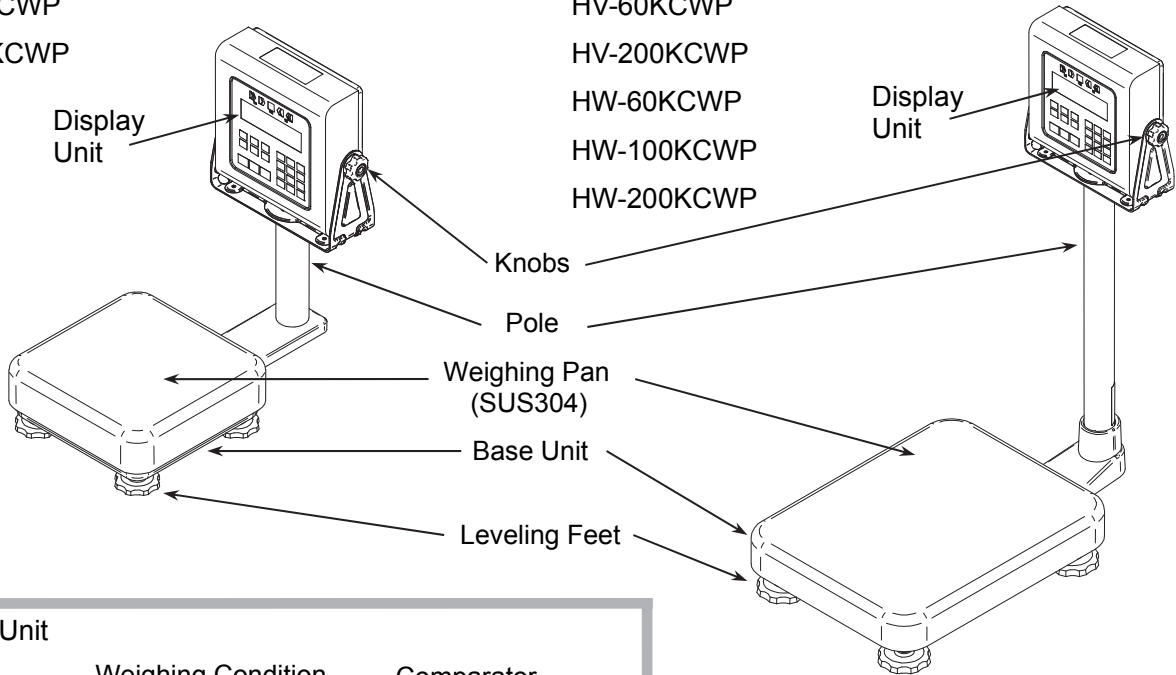

Display Unit

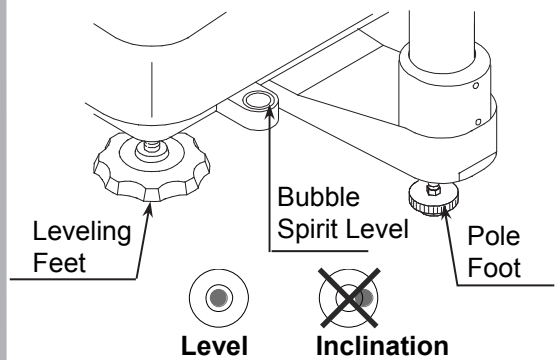
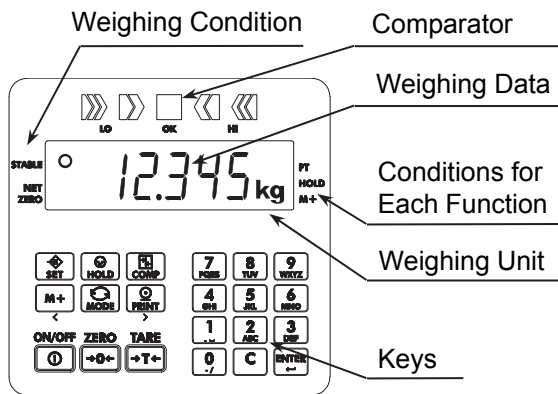



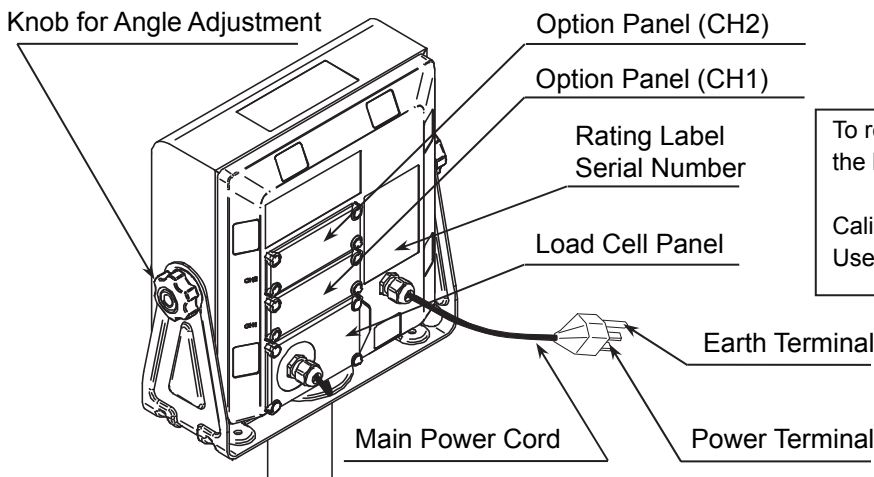



The Rear of the Display Unit







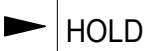

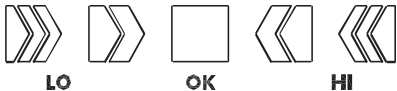
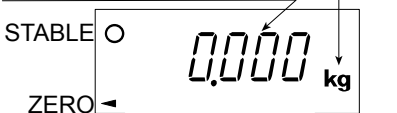
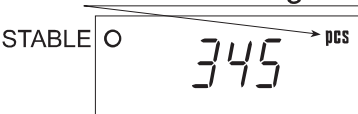
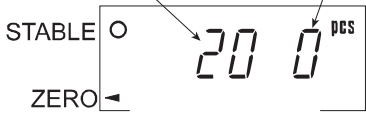

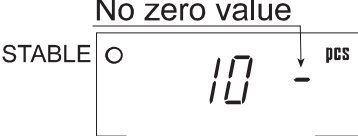

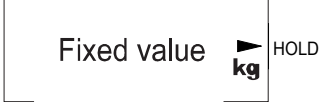
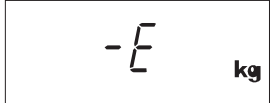
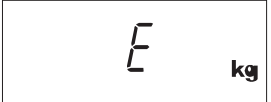
To reveal the terminal and CAL switch, open the load cell panel.

Calibrate the scale to weigh correctly. Use the proper OIML class calibration mass.

















6.1. Display and Symbols

Display and Symbols	Description
	<p>Stability indicator</p> <p>When the current weighing value is stable, this indicator is displayed. It means the scale is in the proper condition for reading weighing values.</p>
	<p>Zero point indicator</p> <p>The zero point is the reference point for weighing.</p> <p>When the ZERO key is pressed with nothing on the weighing pan, this indicator and a zero value are displayed.</p>
	<p>Net indicator</p> <p>When the TARE key is pressed and a tare weight is taken away, this indicator is displayed. The tare weight (the weight of a container, etc.) is a value to be subtracted from the gross value.</p>
	<p>Preset tare indicator</p> <p>This indicator is displayed while a digitally input tare is used.</p>
	<p>Hold indicator</p> <p>This indicator is displayed while the display is held.</p>
	<p>Accumulation indicator</p> <p>This indicator is displayed while the accumulation function is used.</p>
	<p>Comparator indicator</p> <p>While the comparator function is being used, the weighing value is compared using the preset threshold values and the indicator displays the result.</p>
<p>Weighed mass value unit</p> 	<p>Example: Zero point (the reference point for weighing)</p> <p>When the ZERO key is pressed with nothing on the weighing pan, the zero value, the zero point indicator and stability indicator are displayed.</p>
<p>Unit of counting mode</p> 	<p>Example: Counting mode</p> <p>This mode counts the number of articles on the weighing pan using the preset unit mass.</p>
<p>20 pieces Zero value</p> 	<p>Example: Storing the unit mass for the counting mode</p> <p>The unit mass is stored using 20 samples.</p> <p>The zero value means that no articles are on the weighing pan.</p>

<p>No zero value</p> 	<p>Example: Storing the unit mass of the counting mode The unit mass is stored using 10 samples. Sign "-" means that something is placed on the weighing pan..</p>
	<p>Example: Function settings Select the item using the MODE key and enter it using the ENTER key. Input a parameter using the numerical keys. Store the parameter using the ENTER key.</p>
<p>Example</p> 	<p>Example: While setting preset tare Input a tare value using the numerical keys. Store the value using the ENTER key.</p>
<p>Fixed value</p> 	<p>Example: Hold display The hold display is set using Hold of the function table. When the weighing value is near zero (within the zero band) or changes more than 25% +30 digits, the hold is canceled.</p>
	<p>This error occurs when the mass sensor receives a strong force in the upward direction. Please check if the weighing pan is caught in something or foreign matter is not entering the base part. There is a possibility that the mass sensor or internal circuit has failed.</p>
	<p>Overload display Remove anything that is on the weighing pan.</p>
	<p>Calibration Error Please check if the weighing pan is properly placed or the weight is too light and try again.</p>
	<p>Calibration Error Please check if the weighing pan is properly placed or the weight is too heavy and try again.</p>
<p>Fixed display</p> 	<p>This is an error where the zero value cannot be displayed when the display is turned on. Please remove the items on the weighing pan. If calibration is necessary, perform "Calibration of the Zero Point" in "12.2. Calibration Using the Weight". Or, this is an error where the weighing value is not stabilized when the display is turned on. Avoid a breeze or vibration and check whether the weighing pan is touching something.</p>

Display and Symbols	Description
Blinking  M+	Accumulated data count.
Blinking  M+ and lighting up kg	Total mass value of the accumulated data.
<p>Example: Capacity and readability</p> <p>Max 3 / 6 / 15 kg</p> <p>d= 0.001 / 0.002 / 0.005 kg</p>	<p>The weighing range and measurable minimum mass.</p> <p>Examples:</p> <p>Displays the weighing value in increments of 0.001 kg (1 g) up to 3 kg.</p> <p>Displays the weighing value in increments of 0.002 kg (2 g) up to 6 kg.</p> <p>Displays the weighing value in increments of 0.005 kg (5 g) up to 15 kg.</p>
	Alternating current.
	Earth (ground) Terminal.

6.2. Keys

Keys	Description
ON/OFF 	ON/OFF Key Shows or hides the display alternately. Note: When the main power plug of the scale is connected to the receptacle, the power is supplied to the electric circuit inside the scale.
ZERO 	ZERO Key Based on the zero point weighed at the time of turning on the display (Power on zero function), by pressing the ZERO key when the weight value is stable within $\pm 2\%$ of the weighing capacity, the zero point indicator turns on as soon as the display becomes zero. At this time, if tare function is used, the tare value is deleted. If accumulation data is displayed, the accumulation count and value are deleted.
TARE 	TARE Key By pressing the TARE key when the weighing value is a positive and stable value, the weight of the item on the weighing pan is subtracted as the weight of a container (tare weight), and a zero value and both the zero point and net indicators are displayed. (Tare function) Note: The weighing range is reduced according to value of the tare weight.
	M+ Key Adds to the accumulated data.
	SET Key Selects + and - for limit values in the comparator mode.
Press and hold  and press 	Use these keys to enter the preset tare setting mode.
Press and hold  and press 	Use these keys to display the accumulated results.
Press and hold  and press 	Use these keys to set limit values for the comparator.
	MODE Key Switches the weighing unit to be displayed. This key is used to select the items at each setting.
	HOLD Key Holds the display. (Refer to “13. Function” for details)
	PRINT Key Outputs the displayed weighing data. (Refer to “13. Function” for details)
Display off  Press and hold  and press 	Use these keys to enter the function mode.



7. Basic Operation

7.1. Turning the Scale ON/OFF and Weighing

- Step 1 Ground the scale using the earth terminal.
- Step 2 Confirm that nothing is placed on the weighing pan.
- Step 3 Confirm that local voltage and receptacle type are correct before connecting the scale.
- Step 4 The scale is turned on or off using the **ON/OFF** key.
- Step 5 Check the accuracy of weighing.
Allow a 30-minute warm up period before calibration
- Step 6 With nothing on the weighing pan, press the **ZERO** key to display the zero value.
- Step 7 Gently place an article to be weighed on the weighing pan.
- Step 8 Wait for the stability indicator to be displayed, then read the weighing value.
- Step 9 Gently remove the article from the weighing pan.
- Step 10 Turn off the display using the **ON/OFF** key.

Note

When the display is turned off by pressing the **ON/OFF** key, the power is still being supplied inside the circuit of the scale. To shut off the power completely, disconnect the power cord of the scale from the receptacle.

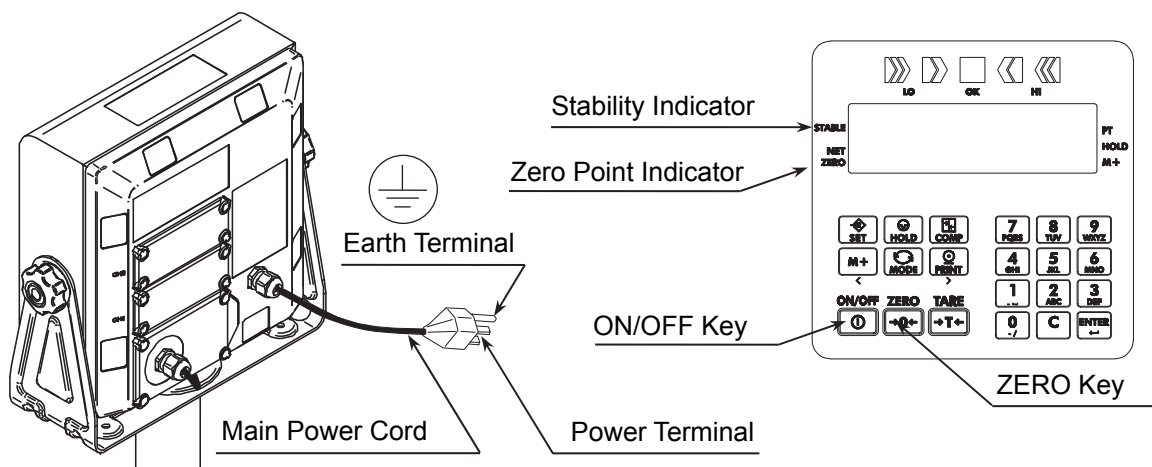

⚠ Please confirm that the local voltage and the receptacle type are correct for your scale.

7.2. Power on Zero Function and Power on Tare Function

Power on Zero Function:

When nothing is placed on the weighing pan and the scale is turned on using the **ON/OFF** key, the weighing value is assumed as the reference value of weighing. The zero value as gross value and zero point indicator are displayed. The power on zero function can be used when the weighing value is within the threshold value * from the zero point at calibration.

Power on Tare Function:

When a tare weight (container) is placed on the weighing pan and the scale is turned on using the **ON/OFF** key, the tare function is performed and a zero value is displayed as net value. Zero point indicator and net indicator are displayed. The power on tare function can be used when the current zero point is more than the threshold value * from the zero point of calibration.

Active function	* Threshold value	
	Principal standard models	Approved models
Power on zero function	±50 % of capacity	±10 % of capacity
Power on tare function	+50 % of capacity	+10 % of capacity

7.3. Tare Function

The tare function is used when weighing an article in a container to display only the mass of the content (net weight) by subtracting the mass of the container (tare weight).

⚠ CAUTION

- ❑ The weighing range is reduced according to the value of the tare weight.
- ❑ The current net value is reset to zero value when the **ZERO** key is pressed or the display is turned off.
- ❑ The storable preset tare value is within the minimum weighing range

7.3.1. How to Weigh a Tare Weight

- Step 1 Place the container on the weighing pan.
- Step 2 Wait for the stability indicator to be displayed, then press the **TARE** key.
The display becomes zero value.
- Step 3 Place an article to be weighed into the container.
Wait for the stability indicator to be displayed, and then read the value.
- Step 4 Remove all of the articles and the container from the weighing pan.

7.3.2. How to Input Value of a Tare Weight with Numerical Keys (Preset Tare)

- Step 1 While pressing and holding the **SET** key, press the **TARE** key.
The scale displays a blank display or the stored tare value. A blank display means that the tare value is zero (reset value). And ► PT blinks.
- Step 2 Input the preset tare value using the numerical keys.
- Step 3 Press the **ENTER** key to store the new preset tare value.
The scale displays the net value as preset tare value subtracted from gross value.
- Step 4 Place an article to be weighed into the container.

Wait for the stability indicator to be displayed, and then read the value.

Step 5 Remove all of the articles and the container from the weighing pan.

7.4. Switching the Mode

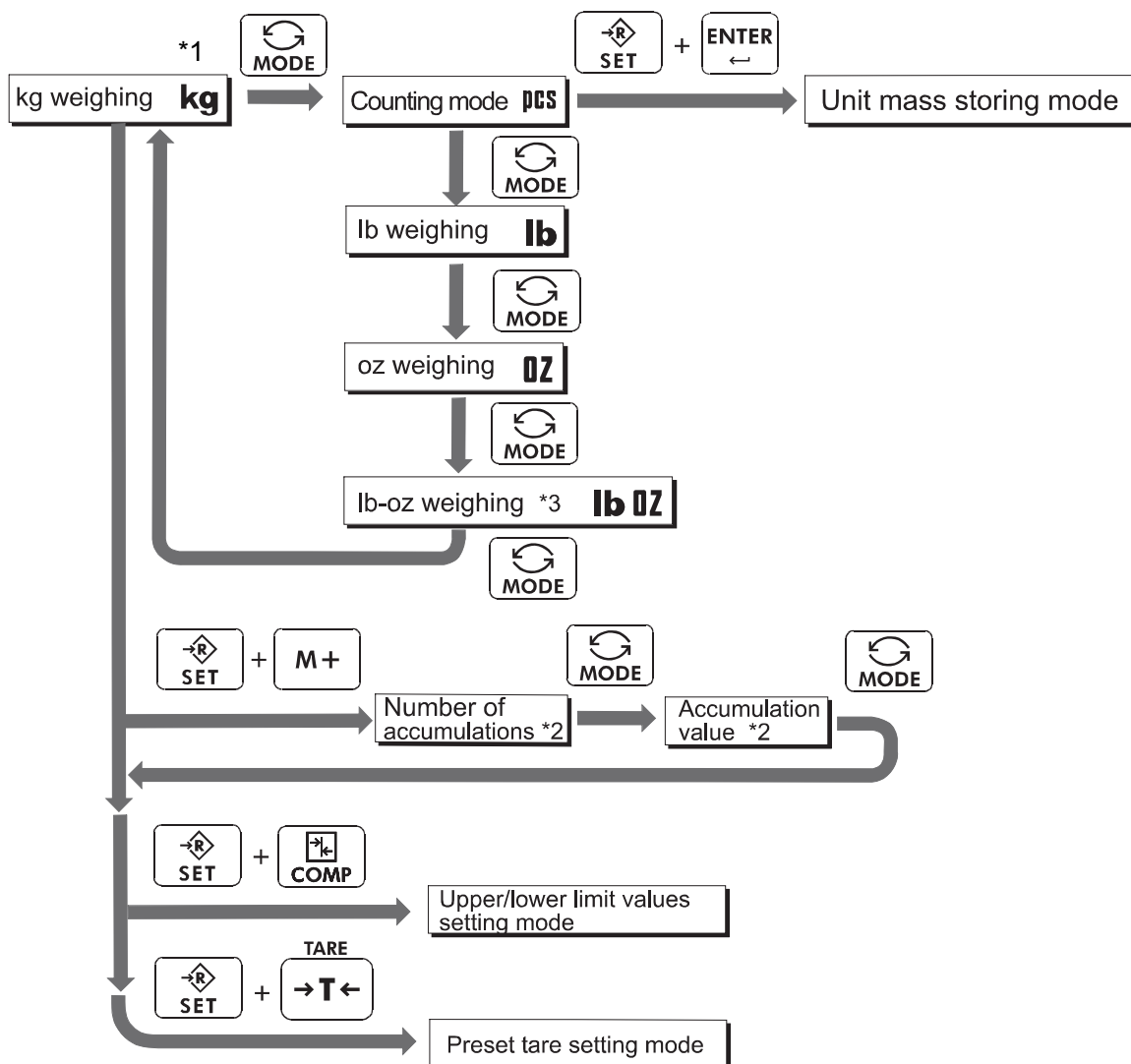

- *1 The weighing unit used when turned on is the last weighing unit used before turning off.
- *2 When accumulation data is stored in the scale, the number of accumulations and an accumulation value can be displayed.
- *3 The lb-oz display is only available with HV-15KCWP and HW-10KCWP.



8. Counting Mode

- ❑ The counting mode is the function to convert the total mass value (total weight) of articles to a count, when each article has the same mass value.
- ❑ To use this function, store a unit mass in advance.
- ❑ Even if the power is turned off, the unit mass is maintained in non-volatile memory.

8.1. Storing a Unit Mass

Step 1 Press the **MODE** key to display the unit pcs.

Step 2 Press the **ENTER** key while pressing and holding the **SET** key to enter the mode for storing a unit mass.

Step 3 Press the **SET** key to select the number of samples:
5 pieces, 10 pieces, 20 pieces, 50 pieces or 100 pieces.
The greater the quantity of samples, the greater the accuracy of the count.

Step 4 Place the container on the weighing pan.
Press the **TARE** key.

Step 5 Place the number of samples selected at Step 3.
After the stability indicator is displayed, press the **ENTER** key to store it.

⚠ CAUTION

- ❑ When the sample total mass value is too small and it is not possible to calculate a unit mass, the scale displays **Lo ut** and returns to step 3. Increase the number of samples. The total sample mass are required more than 10 times of readability in kg.
- ❑ When the unit mass is too small to store, the scale displays **Lo ut**. . In this case, the unit mass will not be stored even if the number of samples is increased.
- ❑ To return to the weighing mode, press the **MODE** key.

Step 6 The count is displayed.

Step 7 Remove the samples and the container from the weighing pan.

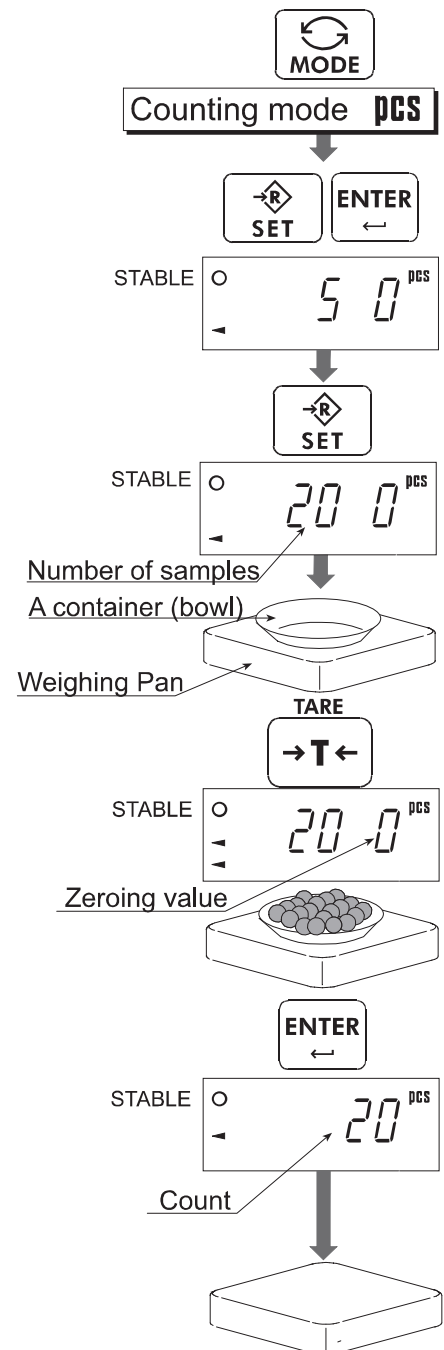

Note
The weighing pan shape depends on the scale model.

8.2. Counting the Number of Articles

Step 1 Press the **MODE** key to display the unit pcs.

Step 2 Store the unit mass of the articles.
Refer to “8.1. Storing a Unit Mass”

Step 3 Place the container on the weighing pan.
Press the **TARE** key to display a zero value.

Step 4 Place articles in the container to read the count.

Step 5 Remove the articles and the container from the weighing pan.

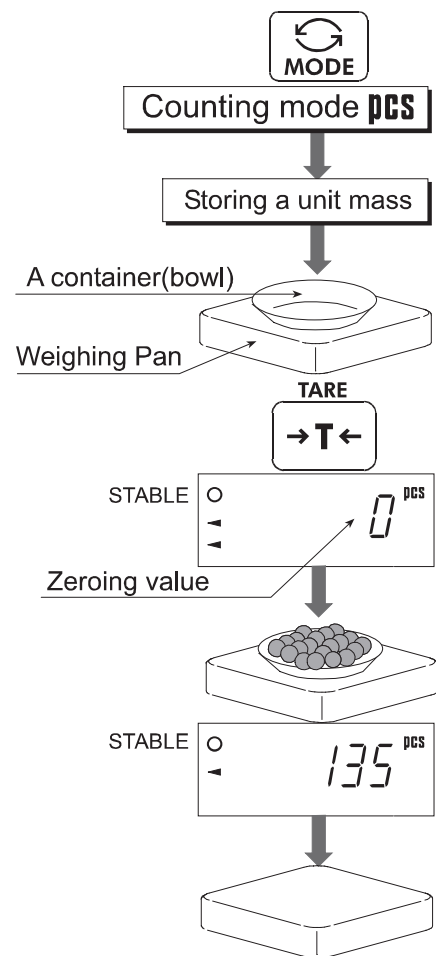

Note
The weighing pan shape depends on the scale model.



9. Accumulation Function

- The accumulation function can display the accumulation count and accumulation mass value of articles to be weighed. Maximum accumulation count is 999 times.
- The accumulation function is displayed with up to 6 digits and cannot display the leading digits of 7 or more digits.
Example: If a 60 kg sample is weighed 17 times, the total is 1020.000 kg. ($60.000 \times 17 = 1020.000$). Therefore, the scale displays a 020000.
- To use this function, set the parameters of the accumulation mode 5uñ in the function table in advance.
- The total count and total mass value are stored in the scale even if the power is turned off.
- Accumulations cannot simultaneously be performed using multiple weighing units.

Display and Key Operations of Accumulation Function

Accumulation count display: Displays a blinking  M+ without a weighing unit

Accumulation mass value display: Displays a blinking  M+ with a weighing unit

To display the accumulation result, press the M+ key while pressing and holding the SET key in the weighing mode.

Accumulation count is displayed.

Press the MODE key.

Accumulation mass value is displayed.

Press the MODE key.

The display returns to the weighing mode.

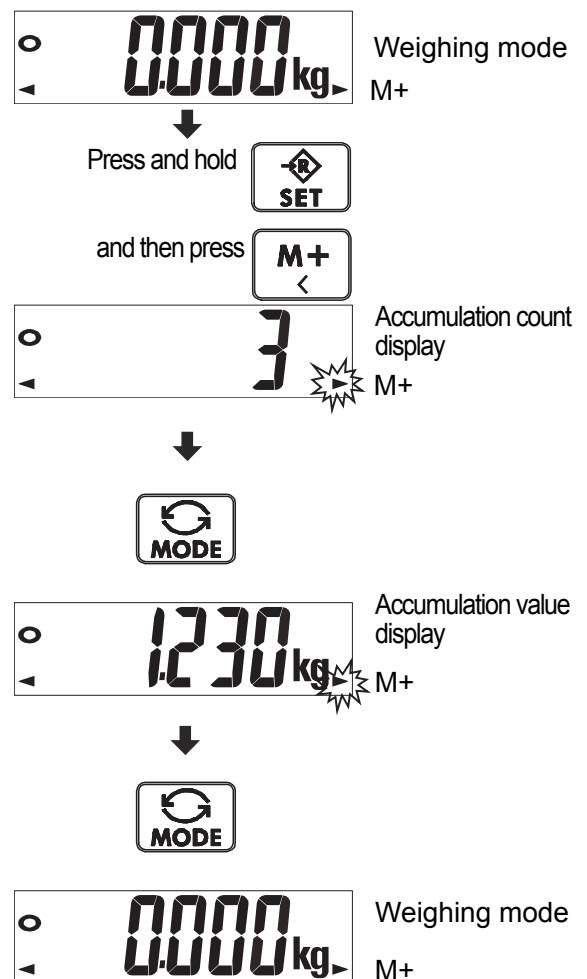

- When the **ZERO** key is pressed while an accumulation count or value is displayed, the accumulation data is reset to zero. (When the display returns to weighing mode, the **M+** is turned off.)
- When the **PRINT** key is pressed while an accumulation count or value is displayed, the accumulation result (accumulation count and value) can be output. (When using the optional HVW-02BCWP: USB interface or optional HVW-03CWP: RS-232C interface.)
- Select the accumulation conditions with function item **50n**.

Function setting	Description
50n 0	Accumulation function not used.
50n 1	When the weighing value is a positive stable value and not "near zero", if the M+ key is pressed, the value is accumulated. The next accumulation can be performed after the display becomes "near zero" or a negative value.
50n 2	When the weighing value is a positive stable value and not "near zero", if the M+ key is pressed, the positive value is added to the accumulation value. When the weighing value is a negative stable value and not "near zero", if the M+ key is pressed, the negative value is subtracted from the accumulation value. The next accumulation can be performed after the display becomes "near zero".
50n 3	When the weighing value is a positive stable value and not "near zero", the value is accumulated automatically. The next accumulation can be performed after the display becomes "near zero" or a negative value. Use: To weigh each article and accumulate the count and total mass value.
50n 4	When the weighing value is a positive stable value and not "near zero", the positive value is added to the accumulation value automatically. When the weighing value is a negative stable value and not "near zero", the negative value is subtracted from the accumulation value automatically. The next accumulation can be performed after the display becomes "near zero".

* Near zero means a range of $-4 d$ to $+4 d$ in kg ($d = \text{readability}(\text{scale interval or "division"})$).



10. Comparator

- Each comparator mode compares the weighing value against the preset threshold values and outputs the results using LEDs (yellow / green / red).
- The comparator function can select a mode from "Five-level comparator mode", "Three-level comparator mode (Upper and lower limit mode)" and "Seven-level comparator mode (Ranking mode)".
- When the optional comparator relay output (HVW-04CWP) is installed into the scale, the comparison result can sound the buzzer synchronized to LEDs and output as relay signal.

Five-Level Comparator Mode:

This mode compares the weighing value with four threshold values (limit values) and outputs results in five levels of LOLO, LO, OK, HI and HIHI.

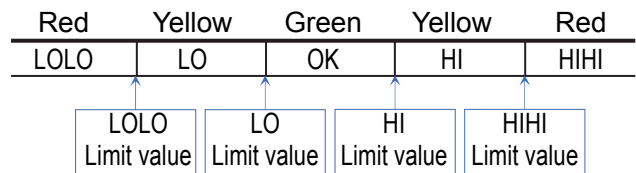

Three-Level Comparator Mode (Upper and lower limit mode):

This mode compares the weighing value with two threshold values (upper and lower limit) and outputs results in three levels of LO, OK and HI.

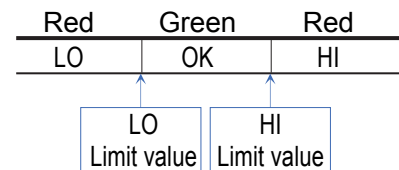

Seven-Level Comparator Mode (Ranking Mode):

This mode compares the weighing value with five threshold values and outputs results in seven ranks.

Out of range (Negative value),
 Rank 1 (LOLO), Rank 2 (LO),
 Rank 3 (OK), Rank 4 (HI),
 Rank 5 (HIHI),
 Out of range (Positive value)

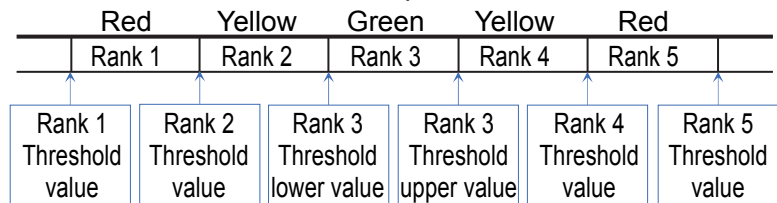

- To use the comparator modes, item $\boxed{CP-L}$ and \boxed{CP} of the function table must be specified and threshold values (limit values) of the comparator must be set in advance.
- Select a comparator mode at item $\boxed{CP-L}$ of the function table.
 - 0 : Five-level comparator mode.
 - 1 : Three-level comparator mode (upper and lower limit mode).
 - 2 : Seven-level comparator mode (ranking mode).
- Select a comparator condition at item \boxed{CP} of the function table.
 - 0 : No comparison (comparator function not used).
 - 1 : All data is compared regardless of stability of value.
 - 2 : Stable data is compared.
 - 3 : All data is compared regardless of stability of value except "near zero".
 - 4 : Stable data is compared except "near zero".
 - 5 : All positive data is compared except "near zero".
 - 6 : Stable positive data is compared except "near zero".

Note

- * Near zero means a range of $-4 d$ to $+4 d$ in kg ($d = \text{readability}(\text{scale interval or "division"})$).

10.1. Setting a Mode and Method

Step 1 Turn off the scale using the **ON/OFF** key.

While pressing and holding the **TARE** key, press the **ON/OFF** key to enter the setting mode.

Then the software version **P-XXX** is displayed.

Press the **MODE** key to enter the function table and class **bASFnC** is displayed.

Step 2 Select class **[CP Fnc]** using the **MODE** key. Press the **ENTER** key to store it.

Step 3 Item **[CP-L 0]** is displayed. Input a parameter for the mode using the numerical keys. Press the **MODE** key to proceed to next step.

Step 4 Item **[CP]** is displayed. Input a parameter for the comparison method using the numerical keys. Press the **ENTER** key to store it. The scale returns to class level after **End** is displayed

Step 5 When the **ZERO** key is pressed, the scale returns to the weighing mode.



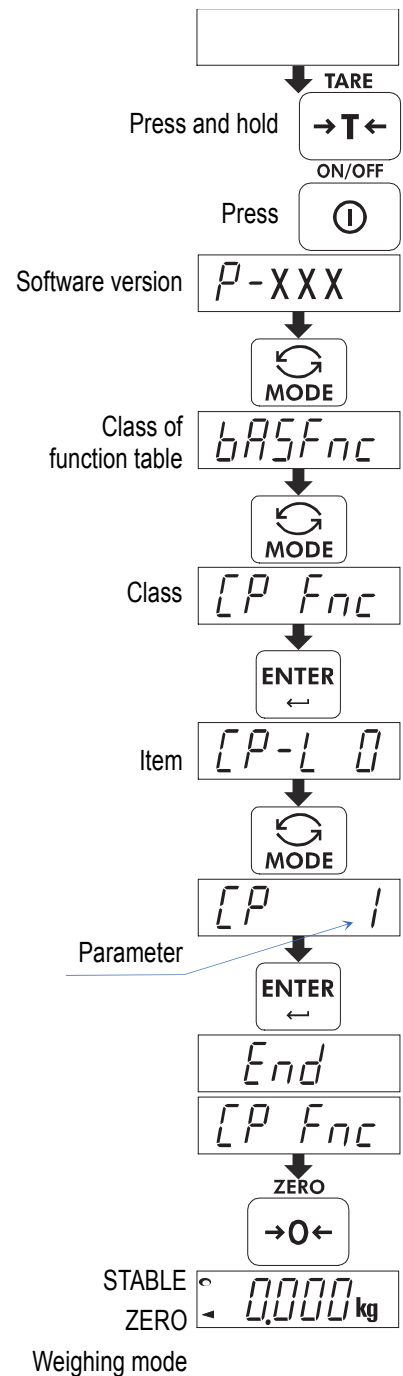

Step 6 Proceed to "10.3. Setting Threshold Values" to use the comparator mode.





10.2. Comparison and Formula

Judgment of comparison is performed using the formulas below. The result is displayed to the comparator indicator and output to option interface.

Five-Level Comparator Mode







Result	Comparison formula	LED	Relay output
LOLO	Displayed value < LOLO limit value or, Displayed value < Out of range (Negative value)	 LOLO Red	LOLO
LO	Displayed value < LO limit value	 LO Yellow	LO
OK	LO limit value ≤ Displayed value ≤ HI limit value	 OK Green	OK
HI	HI limit value < Displayed value	 HI Yellow	HI
HIHI	HIHI limit value < Displayed value or, Out of range (Positive value) < Displayed value	 HIHI Red	HIHI

Three-Level Comparator Mode (Upper and Lower Limit Mode)

Result	Comparison formula	LED	Relay output
LO	Displayed value < LO limit value or, Displayed value < Out of range (Negative value)	 LOLO Red	LOLO
OK	LO limit value ≤ Displayed value ≤ HI limit value	 OK Green	OK
HI	HI limit value < Displayed value or, Out of range (Positive value) < Displayed value	 HIHI Red	HIHI

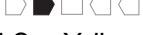
Caution The LO result is output to LOLO LED and LOLO option output.
The HI result is output to HIHI LED and HIHI option output.

Seven-Level Comparator Mode (Ranking Mode)

Result	Comparison formula	LED	Relay output
None	Displayed value < Limit Lower value of Rank 1 or, Displayed value < Out of range (Negative value)	 No LED	-
Rank 1 (LOLO)	Displayed value < Limit Lower value of Rank 2	 LOLO Red	LOLO
Rank 2 (LO)	Displayed value < Limit Lower value of Rank 3	 LO Yellow	LO
Rank 3 (OK)	Limit Lower value of Rank 3 ≤ Displayed value ≤ Limit Upper value of Rank 3	 OK Green	OK
Rank 4 (HI)	Limit Upper value of Rank 3 < Displayed value	 HI Yellow	HI
Rank 5 (HIHI)	Limit Upper value of Rank 4 < Displayed value	 HIHI Red	HIHI
None	Limit Upper value of Rank 5 < Displayed value or, Out of range (Positive value) < Displayed value	 No LED	-

- Threshold values of limits and ranks are common to both the weighing and counting mode. These threshold values are maintained even if the power supply is off.
- Ignore the decimal point when setting threshold values of limits and ranks.
- Comparison is performed in order from the top row to the bottom of each table.
- These threshold values are not judged. Even if the relation between threshold values is not proper, no error will be output.

10.3. Setting Threshold Values (of Limits and Ranks)

Step 1 While pressing and holding the **SET** key, press the **COMP** key to enter the comparator value setting mode.

Step 2 Input a parameter for the comparison method using the numerical keys of **0** to **9**.
SET: Key to alternate between +/-, **ENTER**: Key to store and proceed, **C**: Cancel key

Step 3 When settings of threshold values (of limits and ranks) are finished, **End** is displayed.
 (At this time, power-on-zero is not performed.)

Five-Level Comparator Mode	Three-Level Comparator Mode (Upper and lower limit mode)	Seven-Level Comparator Mode (Ranking Mode)
Example: HW-60KC-WP	Example: HV-200KC-WP	Example: HV-15KC-WP
LOLO 8.500 kg	LO 148.85 kg	Rank 1 (LOLO) 0.500 kg or more
LO 10.000 kg	HI 152.50 kg	Rank 2 (LO) 1.000 kg or more
HI 10.500 kg		Rank 3 (OK) 1.500 kg to 2.000 kg
HIHI 12.000 kg		Rank 4 (HI) up to 2.500 kg
		Rank 5 (HIHI) up to 3.000 kg

- The HV-CWP models change the position of the readability depending on the weighing range. Regard the hidden minimum digit as "0". The HV-CWP models are as follows : HV-15KCWP, HV-60KCWP, HV-200KCWP.

10.4. Buzzer Setting

Installing the optional HVW-04CWP comparator relay output on the scale allows the buzzer to sound in conjunction with LEDs according to the comparison result.

The buzzer can be set by using the **[1]**, **[2]**, **[3]**, **[4]**, and **[5]** numerical keys when **buZZ** of the function table is displayed.

To set the buzzer to sound according to comparison result, select the corresponding numerical key to light up the LED (showing that the buzzer is on) or turn it off (showing that the buzzer is off).

Each LED can be toggled between on and off by pressing the corresponding key.

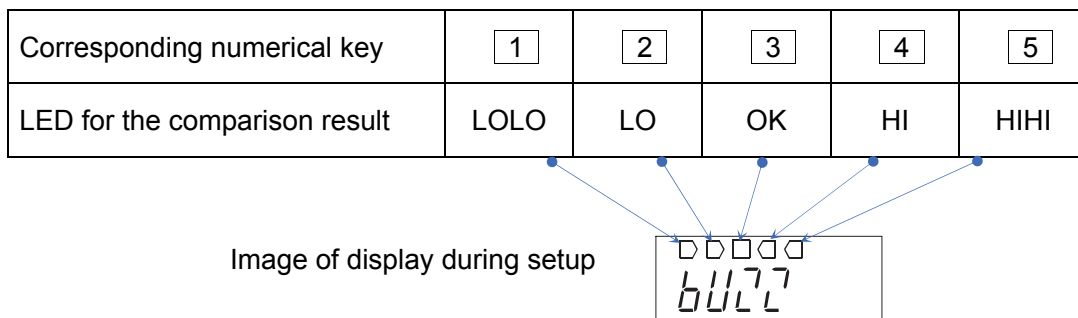

Example :

When the result is LOLO or OK, the buzzer sounds.

Step 1 Press the **[1]** key to light up the LED for LOLO.

Step 2 Press the **[3]** key to light up the LED for OK.

Step 3 Press the **[ENTER]** key to store the settings.

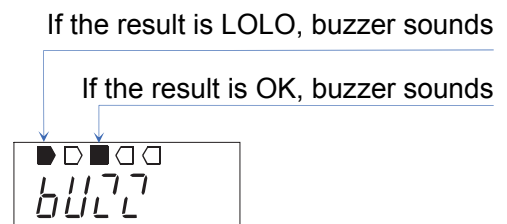

Caution

When the three-level comparator mode is used, **[1]** LOLO, **[3]** OK and **[5]** HIHI are used for buzzer settings. **[2]** HI and **[4]** LO are not used.

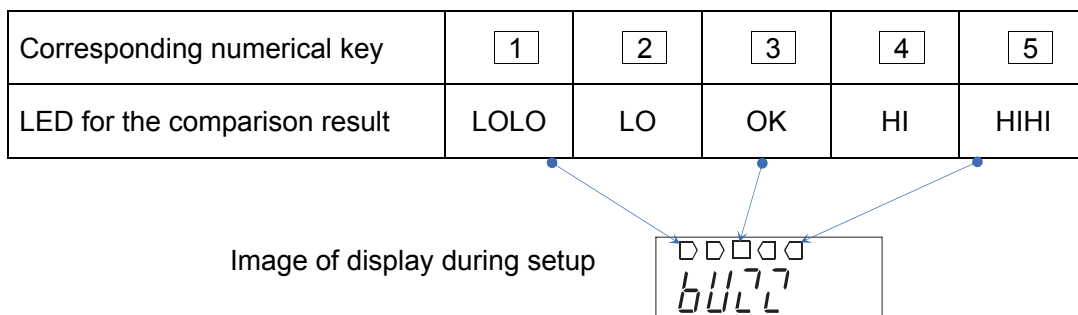



11. Auto-tare Function

The HVC-WP / HWC-WP series has an auto-tare function to be used with the comparator mode enabled. Using this function in check weighing, the scale automatically tares, then displays OK for a certain amount of samples and repeats this process for the next weighing.

Start with display zero value after tare operation. Place or take away objects until the comparison result shows OK.

When the stable display is maintained for the duration specified in the function setting $\boxed{Rt-t}$, the scale will automatically tare the weighing value, show zero value and be ready for next weighing.

- ❑ In some countries or areas, the auto-tare function can not be used on the Legal for Trade models and the selection in the function settings \boxed{Rt} , $\boxed{Rt-t}$ and $\boxed{Rt-F}$ is not available.
- ❑ To use the auto-tare function, set the function settings below.

Function settings	Contents
\boxed{CP} 1	Compare all weighing data (other settings may be used depending on the application).
\boxed{Rt} 1	Auto-tare function enabled.
$\boxed{Rt-t}$ 0 to 9	Select the timing to tare automatically to avoid the wrong tare operation, for example, too early to tare or too late to go to the next weighing.

- ❑ Take-away check weighing $\boxed{CP-P}$ 1 (Example with $\boxed{CP-L}$ 0 setting)
Take-away check weighing (negative comparison) is the way to compare a negative weight while taking away objects from a container.
Set the function $\boxed{CP-P}$ 1 together with the auto-tare function enabled \boxed{Rt} 1. In this operation mode, the scale operates as “take-away the objects” → “OK and stable” → “auto-tare” → “take-away the objects” →
In this setting, the polarity of LOLO, LO, HI, and HIHI limit values are ignored and the scale shows the comparator results as below.

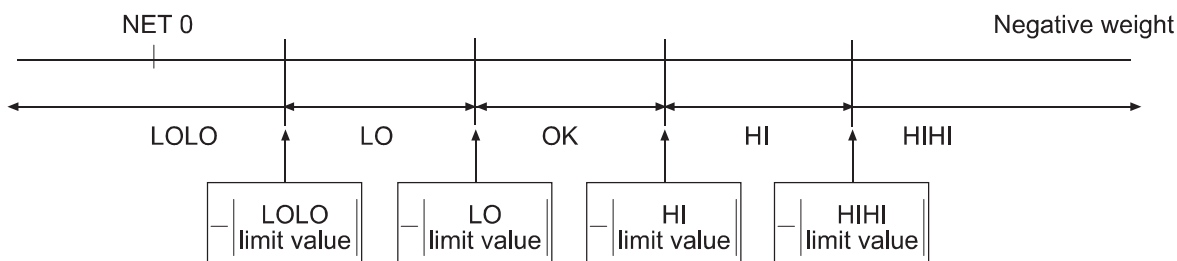

Note: To start take-away check weighing, be sure to use the \boxed{TARE} key to tare the weight of the container filled with objects. The \boxed{ZERO} key may zero the display, but the scale goes below the zero point by taking away the objects. Then, the auto-tare function or \boxed{TARE} key does not work.

- ❑ When the function "Tares the initial weighing value (of container) $\boxed{Rt-F}$ 1" is selected :
To start the auto-tare function, usually the container (filled with objects) will be placed on the weighing pan and its weighing value must be tared using the \boxed{TARE} key.
When $\boxed{Rt-F}$ 1 is selected, the scale will tare the initial weighing value (of container) automatically. When the entire load on the weighing pan is removed, the scale will return to the zero point and the value of the tare weight will be automatically cleared. If the scale does not return to the zero point, press the \boxed{ZERO} key to clear the tare weight.
- ❑ If the scale is equipped with the optional USB interface (HVW-02BCWP) or optional RS-232C serial interface (HVW-03CWP), the OK weighing data can be output automatically. Set the function setting \boxed{PrEt} 1 to $\boxed{7}$ or $\boxed{8}$.



12. Calibration

Calibration is the function used to adjust the scale so that it can display the proper mass value.

Calibration must be performed in the following cases.

- When the scale is initially installed
- When the scale is moved to a location far away
- When the ambient environment has greatly changed
- At periodic calibration

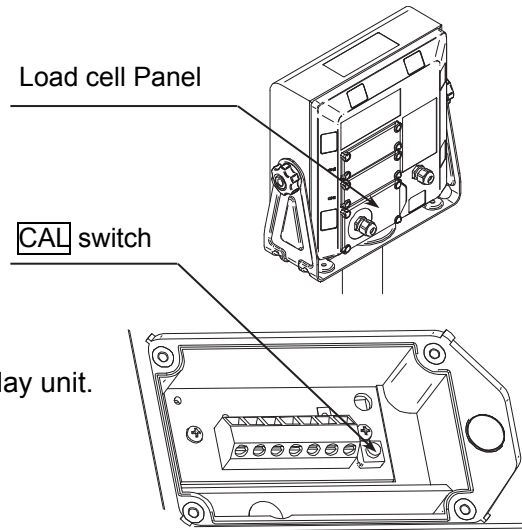

12.1. Calibration Procedure

Step 1 Turn on the display. Open the rear cover of the display unit.

Locate the **CAL** switch inside.

Press the **CAL** switch to enter the calibration mode.

Then **[CAL]** is displayed.

Step 2 Select one of the following items to calibrate the scale.

[ENTER] : To calibrate using the calibration weight (Refer to “12.2. Calibration Using the Weight”).

[MODE] : To calibrate using the gravity acceleration value setting (Refer to “12.3. Setting the Gravity Acceleration”).

12.2. Calibration Using the Weight

Calibration of the Zero Point

Step 1 Keep the display turned on for at least 30 minutes to warm up the scale. Keep in mind the items of “4.1. Precautions for Installing the Scale”.

Step 2 Press the **[ENTER]** key while **[CAL]** is displayed to display **[CAL 0]**.

Step 3 Confirm that nothing is placed on the weighing pan.

Wait for the stability indicator to be displayed.

Press the **[ENTER]** key.

The scale stores the current condition as the zero point.

Step 4 Calibration of the zero point is finished. To exit the calibration mode at this step, press the **CAL** switch. The display will then be turned off

Note
The weighing pan shape depends on the scale model.

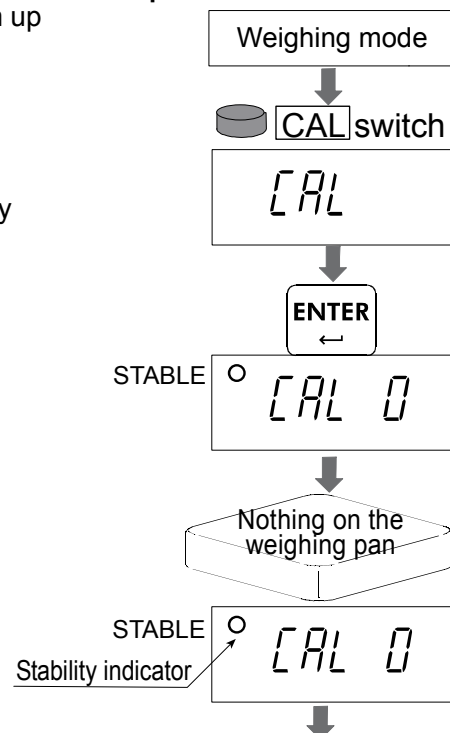

Span Calibration

Step 5 The value of the calibration weight to be placed on the weighing pan is displayed (The initial value depends on the scale model).

The value for the calibration weight can be entered using the numerical keypad.

To obtain proper weighing performance from the scale, we recommend using a weight more than two-thirds the weighing capacity.

Step 6 Place a weight of the value displayed on the pan. Wait for the stability indicator to be displayed. Press the **ENTER** key.

Step 7 Calibration using the weight is finished. **END** appears after displaying **End**. Remove the weight from the pan.

Step 8 Press the **CAL** switch to turn the display off. Calibration using the weight is finished.

Step 9 Press the **ON/OFF** key to turn the display on. Confirm that weighing can be performed properly.

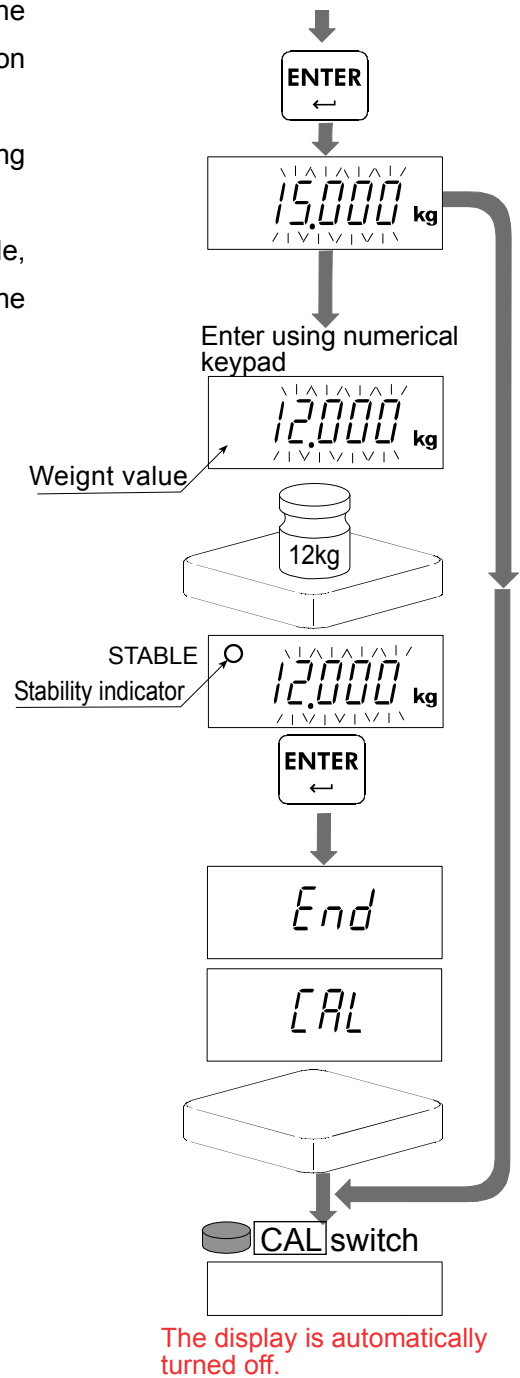

12.3. Setting the Gravity Acceleration

When the scale is initially installed or is moved to another location, the scale must be calibrated using the calibration weight. But if the calibration weight cannot be prepared, change the gravity acceleration of your scale to the value of the area where the scale is used. See “Gravity Acceleration Map” of this manual.

Step 1 Press the **MODE** key while **CAL** is displayed.

Step 2 The scale enters the gravity acceleration correction mode.
Press the **ENTER** key to make the numerical value blink and proceed to input mode.

Step 3 Set your local gravity acceleration using the numerical keypad.

Step 4 Press the **ENTER** key to store the new value.
The display returns to gravity acceleration display after displaying **End**.

Step 5 Press the **CAL** switch to turn the display off.
Gravity acceleration setting is finished at this step.

Step 6 Press the **ON/OFF** key to turn the display on.
Confirm that weighing can be performed properly.

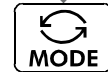
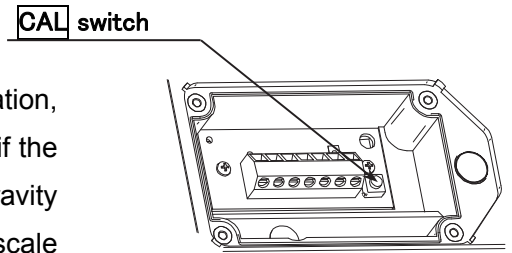

Enter using numerical keypad

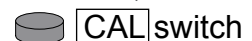
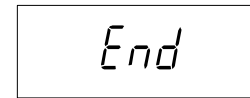

The power is automatically turned off.



13. Function

- ❑ The function table is used to store and refer items that determine the performance of the scale. Each item has a parameter.
- ❑ The parameters are stored in the scale even if the power is removed.

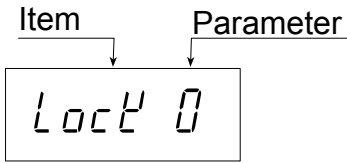

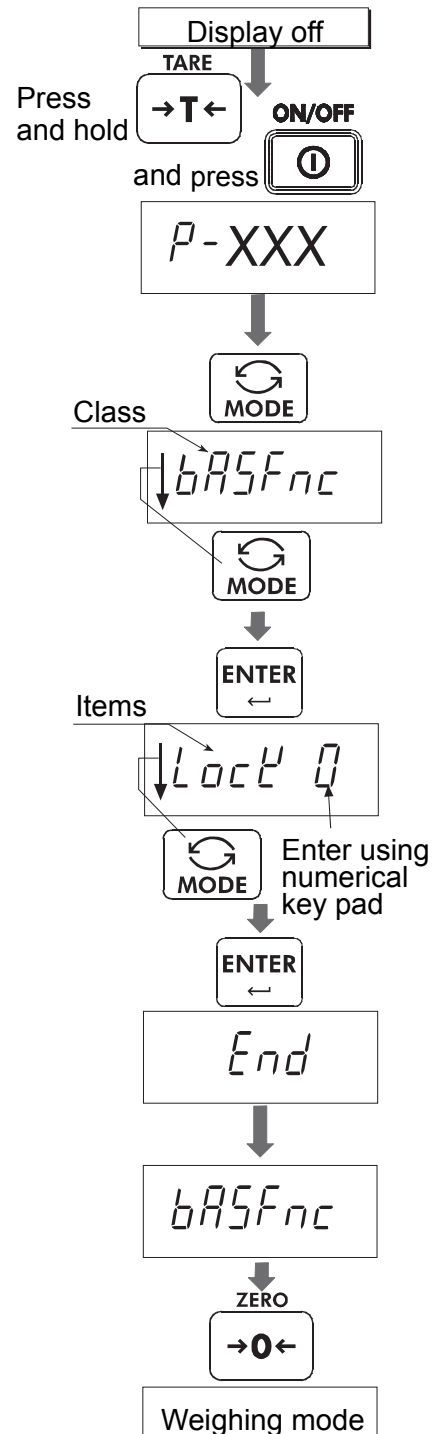

13.1. Parameter Setting Procedure

- Step 1 Press the **ON/OFF** key to turn the display off.
- Step 2 While pressing and holding the **TARE** key, press the **ON/OFF** key to display the software version **P-XXX**. Release the keys.
- Step 3 Press the **MODE** key to enter function setting mode.
Class **bASFnC**.
- Step 4 Press the **MODE** key to select the desired class, and then press the **ENTER** key.
- Step 5 The first item of class is displayed.
Press the **MODE** key to select the desired item, and then enter a value using numerical keypad.
- Step 6 Press the **ENTER** key to store. The display returns to class after displaying **End**.
- Step 7 Press the **ZERO** key to return to normal weighing mode.



13.2. Parameter List

For the HV-CWP series NTEP/Measurement Canada version, the shaded items in the table below cannot be changed by the user, so these items are not displayed.

Class	Item	Parameter	Details and usage	
bRSFnc	Key lock <i>LocL</i>	0 ■	All keys function	
		1	The ON/OFF , ZERO , TARE , HOLD , M+ and PRINT keys function.	
		2	The ON/OFF , ZERO , TARE keys function.	
	Automatic power off <i>PoFF</i>	0 ■	OFF	
		1	After 5 minutes	
		2	After 10 minutes	
		3	After 15 minutes	
		4	After 30 minutes	
	Automatic power on <i>P-on</i>	0 ■	OFF	
		1	ON *The scale automatically turns the power on by connecting to the power.	
	Zero tracking <i>trc</i>	0	OFF	
		1 ■	ON	
	Stability band width <i>St-b</i>	0 ■	±0.5 d	
		1	±1 d	
		2	±2 d	
	Stability band time <i>St-t</i>	0	0.5 seconds	
		1 ■	1.0 second	
		2	1.5 seconds	
	Response <i>Cond</i>	0		Fast response/poor vibration tolerance (good environment, target weighing)
		1		
		2 ■		
		3		
		4		
	Backlight control <i>L-it</i>	0	Always turned off	
		1	Always lit	
		2 ■	Turns off 5 seconds after stabilizing	
		3	Turns off 10 seconds after stabilizing	
		4	Turns off 15 seconds after stabilizing	
Backlight brightness <i>L-i</i>	0		Dark	
	1			
	2			
	3 ■			
	4			Bright
Decimal point <i>Pnt</i>	0 ■	Dot (.)		
	1	Comma (,)		
Automatic tare <i>At</i>	0 ■	OFF		
	1	ON		

■ factory settings d: readability(scale interval or "division")

Automatic power off: When the specified interval has passed while the display is zero, the display is stable and there is no key operation, the display turns off.

Stability band width: When the weighing value is within a certain width (stability band width) and a certain interval (stability band time) has passed, the scale judges that weighing is stable and lights up the stability indicator. To precisely judge the weighing until it is stabilized, set the numerical value to be small. To loosely judge, set the numerical value to be large.

Stability band time: When the weighing value is within a certain width (stability band width) and a certain interval (stability band time) has passed, the scale judges that weighing is stable and lights up the stability indicator. To precisely judge the weighing until it is stabilized, set the numerical value to be large. To loosely judge, set the numerical value to be small.

Class	Items	Parameter	Details and usage											
bA5FnC	Interval until making automatic tare At-t	0	0 seconds											
		1	0.5 seconds											
		2 ■	1.0 second											
		3	1.5 seconds											
		4	2.0 seconds											
		5	2.5 seconds											
		6	3.0 seconds											
		7	4.0 seconds											
		8	5.0 seconds											
	9	10 seconds												
	Tare on initial load At-F	0 ■	OFF											
		1	ON											
	Accumulation mode Sun	0	OFF											
		1 ■	Accumulates by M+ key when the value is +, excluding near zero											
		2	Accumulates by M+ key when the value is + or -, excluding near zero											
		3	Accumulates automatically when the value is +, excluding near zero											
	4	Accumulates automatically when the value is + or -, excluding near zero												
	Hold condition Hold	0 ■	OFF											
		1	Holds or releases by the HOLD key											
		2	Automatically holds when detecting stabilization											
	Buzzer buZZ	0 ■	Does not sound (All LEDs are turned off.)											
		LED lighting method * When the registered LED lights up, the buzzer sounds. Set it using the numerical keys. On/off can be switched alternately. Refer to "10.4. Buzzer Setting".												
		<table border="1"> <thead> <tr> <th>Setting key</th> <th>1</th> <th>2</th> <th>3</th> <th>4</th> <th>5</th> </tr> </thead> <tbody> <tr> <td>Result LED</td> <td>LOLO</td> <td>LO</td> <td>OK</td> <td>HI</td> <td>HIHI</td> </tr> </tbody> </table>	Setting key	1	2	3	4	5	Result LED	LOLO	LO	OK	HI	HIHI
Setting key	1	2	3	4	5									
Result LED	LOLO	LO	OK	HI	HIHI									
External contact input 1 Con1	-	Unused												
External contact input 2 Con2	-	Unused												
CPFnC	Comparator judgment value CP-L	0 ■	Five-level comparator											
		1	Three-level comparator (upper and lower limits)											
		2	Seven-level comparator (portion weighing)											
	Comparator judgment condition CP	0	OFF											
		1 ■	Compares all weighing values.											
		2	Compares all stabilized weighing values											
		3	Compares all weighing values, excluding near zero.											
		4	Compares all stabilized weighing values, excluding near zero.											
		5	Compares all positive weighing values, excluding near zero.											
		6	Compares all positive stabilized weighing values., excluding near zero.											

■ factory settings

* Near zero means a range of $-4 d$ to $+4 d$ in kg ($d = \text{readability}(\text{scale interval or "division"})$).

Hold: This function is used to allow the weighing value to easily read by temporarily holding the weighing value. The hold indicator is lit while holding.

Class	Items	Parameter	Details and usage	
	Comparator brightness [P-1]	0	Dark	
		1		
		2 ■		
		3		
		4	Bright	
	Comparator reversal [P-P] *	0 ■	Off	
	1	On		
Status of LED when turning on display [P-d]	0 ■	All LEDs are turned lit. (The comparator relay output is set to OFF)		
	1	All LEDs are off. (The comparator relay output is set to OFF)		
5.5	Baud rate 1 bP51 (CH1)	0 ■	2400 bps	
		1	4800 bps	
		2	9600 bps	
	Bit length, parity 1 bLp1 (CH1)	0 ■	7bit/even	
		1	7bit/odd	
		2	8bit/non	
	Communication format 1 S1F1 (CH1)	0 ■	Standard format (general format for the A&D's scale)	
		1	Standard format, existing returned value	
		2	UFC	
	Baud rate 2 bP52	-	Unused	
Bit length, parity 2 bLPr2	-	Unused		
Communication format 2 S1F2	-	Unused		
Tare data output during tare S1Ft *	0 ■	Not output	Refer to the item "Example of tare function" in "Data format" of "14.6. Communication Format".	
	1	Tare data is output		
dout	Output mode 1 PrE1 (CH1)	0	Stream mode (commands)	
		1	Commands	
		2	Unused	
		3	Unused	
		4 ■	Outputs by the PRINT key (commands)	
		5	Outputs data at auto print setting, +5 digits or more, stable (commands)	
		6	Outputs data at auto print setting, +5 digits or more, or -5 digits or less, stable (commands)	
		7	Outputs data at auto print setting, +5 digits or more, stable, when the comparator is OK (commands)	
		8	Outputs data at auto print setting, +5 digits or more, or -5 digits or less, stable, when the comparator is OK (commands)	
		9	Outputs an accumulation value when the accumulation operation is made (commands)	

■ factory settings

* This item is only displayed on models corresponded to this function, isn't displayed on other models.

Class	Items	Parameter	Details and usage
dout	Time and date adding <i>S t d 1</i> (CH1)	0 ■	Do not output the date and time
		1	Outputs time (ESC T)
		2	Outputs date (ESC D)
		3	Outputs the date and time (ESC D,ESC T)
		4	Unused
		5	Unused
		6	Unused
	ID number adding <i>S i d 1</i> (CH1)	0 ■	Do not output the ID
		1	Outputs the ID
	GMP output <i>i n F 1</i> (CH1)	0 ■	Do not output
		1	Outputs (ESC D, ESC T output)
		2	Outputs (DATE, TIME output)
		3	Unused
	Time and date adding <i>S t d 2</i>	-	Unused
	ID number adding <i>S i d 2</i>	-	Unused
	GMP output <i>i n F 2</i>	-	Unused

■ factory settings

ESC T, ESC D: The time and date uses the calendar function of the AD-8121B and AD-8127.
Use the "dump print mode" of the AD-8121B and AD-8127.

13.3. Initializing Function Settings

The function settings can be returned to factory settings by performing the following steps:

Step 1 Press the **ON/OFF** key to turn off the display.

Step 2 While pressing the **TARE** key, press and hold the **ON/OFF** key until **[CLrFn0]** appears, then release the keys.

Step 3 Press the **SET** key to display **[CLrFG0]**.

Step 4 Press the **ENTER** key while **[CLrFG0]** is displayed.

Function settings are returned to factory settings. The scale returns to the weighing mode after displaying **[End]**.

* This procedure also initializes each comparison value for the comparator.



14. Options

14.1. Options List

Option Name	Description
HVW-02BCWP	USB Interface
HVW-03CWP	RS-232C Interface
HVW-04CWP	Comparator Relay Output / Buzzer
HVW-13	Roller Conveyor for HV-200KCWP, HW-100KCWP and HW-200KCWP
HVW-14	Roller Conveyor for HV-60KCWP and HW-60KCWP
AX-KO3285-320	RS-232C Cable for PC and AD-8127 (D-Sub 9pin, 3m)
AX-KO3341-320	Printer Cable for AD-8121B (3m)
AX-043005266	Indicator Holder

14.2. Installing the Communication Option

Before installing the option to the scale, remove the scale's power cord from the outlet beforehand.

Sections for installing the communication option are located on the display unit rear side.

The HVW-02BCWP or HVW-03CWP can be installed to CH1.

The HVW-04CWP can only be installed to CH2.

⚠ CAUTION

Options other than described above must not be installed on the scale.

Option Panel (CH2)

Option Panel (CH1)

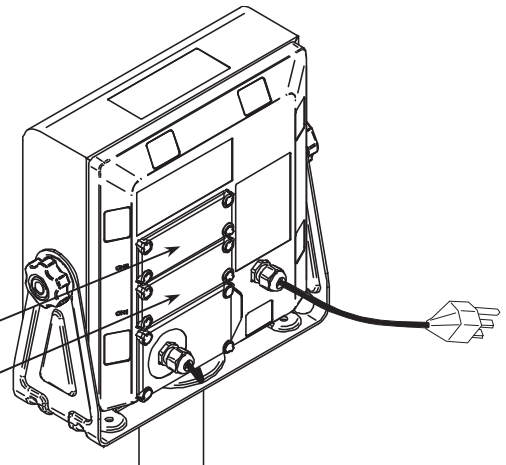

Step 1 Remove the option panel on the display unit rear side.

Step 2 First, pass the cable to be connected to the external device through the panel provided with the option, and then connect it to the terminal on the interface board.

* This procedure is unnecessary for HVW-02BCWP.

⚠ CAUTION

- When the unbundled wire is used for the external connection cable, that prevents dustproof and waterproof performance.
- Use of HVW-02BCWP prevents dustproof and waterproof performance.

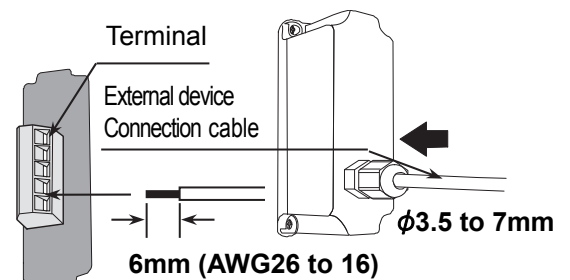

Step 3 Insert the interface board into the provided panel.

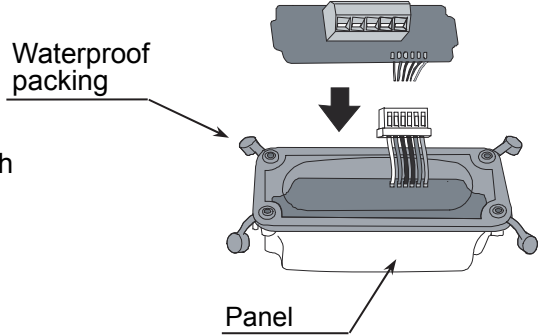

Step 4 Align the waterproof packing match screw hole with the provided panel.

Step 5 Connect the interface board to the display unit's connector.

Step 6 Tighten the four screws of the provided panel.
Cover the head of the four screws using the projecting waterproof packing.

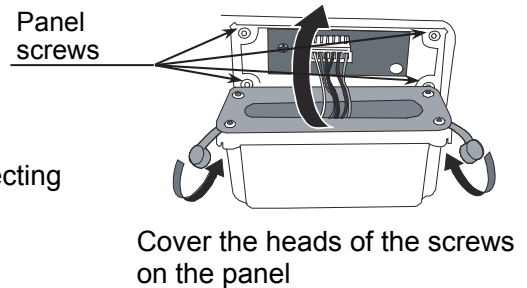

Step 7 Tighten the skin top.
* This procedure is unnecessary for HVW-02BCWP.

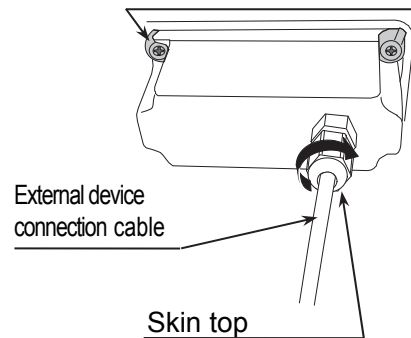

14.3. HVW-02BCWP USB Interface

The HVW-02BCWP enables duplex communication using a USB interface.

The connector is Type Mini-B.

To connect the HVW-02BCWP to a PC, a commercially available "Type A male – Type Mini B male" cable can be used.

To communicate between the scale and a PC using the USB interface, it is necessary to install the specified driver software to a PC. Download the driver software from the A&D website.

The HVW-02BCWP can only be connected with a PC.

Do not use a USB terminal as power supply terminal. Do not connect a device other than a PC to the USB terminal. Doing so may cause of failure and malfunctions.

14.3.1. Procedure for Using the USB Interface

Prepare the PC as shown below.

- Step 1 Download the USB driver software from the A&D website.
- Step 2 Install the USB driver software to the PC that is used as a COM port.
- Step 3 Read the COM port number on the PC.
- Step 4 Input the number to the data communication software.
- Step 5 Connect the scale to the PC using the USB cable.
- Step 6 When the **PRINT** key is pressed, a weighing value can be received by the data communication software.

Example of data communication software : **RsCom** of A&D **WinCT**.

14.3.2. Example of Using the USB Interface

Reading COM port number (Computer is used as a COM port.)

- Step 1 Download the USB driver software from the A&D website.

Open the A&D website at the URL <http://www.aandd.jp/> and open the "Support" and "Software" pages in that order.

Download the driver software from "download" of " Driver software for HVW-02CB. (USB interface option for the HV/W-C & HV/W-CP series)".

Note : The location and version of the software may be changed without notice.

- Step 2 Expand the file " hvw-02cbja_driver.zip " by double-clicking.
The folder " hvw-02cbja_driver " is created.
- Step 3 Install the file " CDM21224_setup.exe " in the folder by double-clicking.
- Step 4 Finish the installation by following the displayed instructions.

Reading the COM port Number (Check after software is installed to the PC.)

- Step 1 Press the **START** button and open the control panel.
- Step 2 Open "Hardware & Sound" and "Device Manager" in that order.
- Step 3 Expand "Ports (COM & LPT)" by double-clicking to display the COM port number.

Port number is "9" in the example.

Note : The COM port number may differ depending on the hardware of the PC. Confirm the COM port number in device manager.

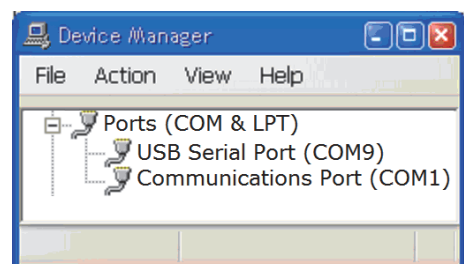

Communication Software

Example: If the communication software WinCT is used, data can be stored in memory.

Step 1 Start RsCOM of WinCT for example.

Step 2 Prepare parameters of "Port: COM".

Port number is "9" in the example.

Note : The communication software WinCT can download from the A&D website of URL <http://www.aandd.jp/>.

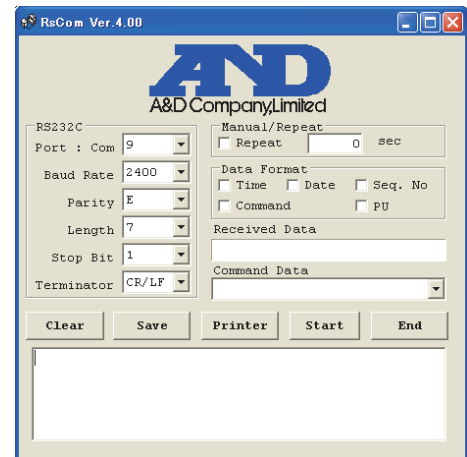

Starting Data Communication

Step 1 Connect the scale to the PC using the USB cable.

*Use a commercially available "type A male - type mini-B male" cable.

Step 2 Press the **START** button of RsCOM of WinCT. Then, communication is available.

Step 3 When the **PRINT** key of the scale is pressed and weighing value is output, RsCOM can receive it.

*The weighing value to be output to the interface depends on parameters of the function table.

14.4. HVW-03CWP RS-232C Interface

The HVW-03CWP enables duplex communication using the RS-232C interface.

To connect the HVW-03CWP to a DTE (Data Terminal Equipment) such as a PC or external device, it is necessary to use a communication cable sold separately.

AX-KO3285-320 Cable for PC or AD-8127 (D-Sub 9 pin 3m, inch screw)

AX-KO3341-320 Cable for AD-8121B (3m)

When confirming the communication format, refer to “14.6. Communication Format”.

Transmission	EIA RS-232C
Transmission form	Asynchronous, bi-directional
Data format	Baud rate : 2400, 4800, 9600 bps
	Data bits : 7 bits + parity 1 bit (even or odd) or 8 bits (non parity)
	Start bit : 1 bit
	Stop bit : 1 bit
	Code : ASCII

Pin Assignments

Pin No.	Signal Name	Direction DCE-DTE	Description
1	RXD	←	Receive Data
2	TXD	→	Transmit Data
3	DSR	→	Data Set Ready
4	SG	-	Signal Ground
5	FG	-	Frame Ground

Names other than TXD and RXD are for the DTE side.

Manufacturer: Phoenix Contact

Model name: SMKDSN 1,5/5-5,08

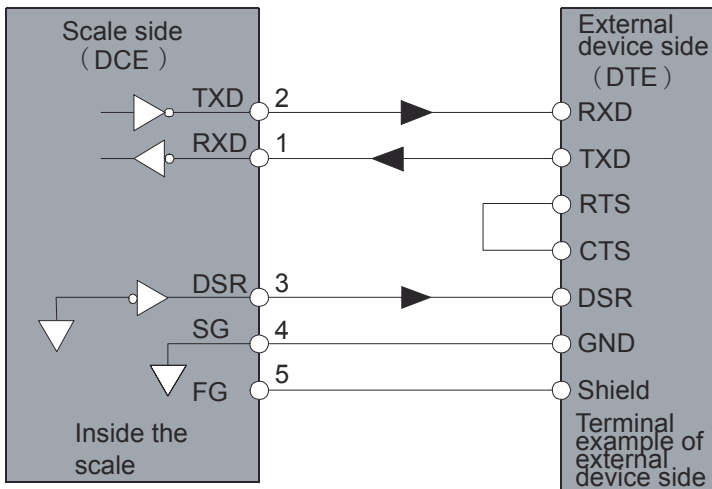
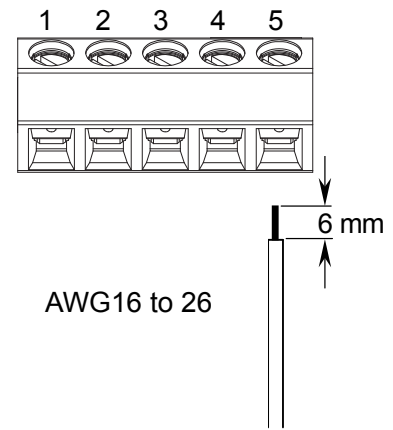

When connecting to AX-KO3285-320

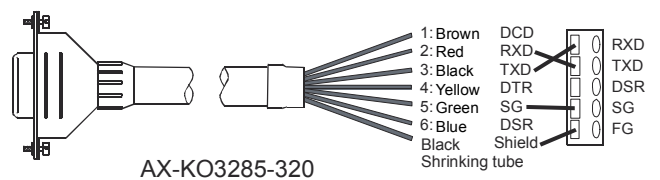

When connecting to AX-KO3341-320

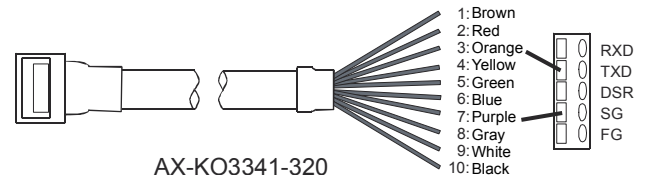

⚠ CAUTION

- When connecting to an external device with hardware flow control, communication will be impossible using a cable without RTS and CTS connected. In that case, connect RTS and CTS. This will disable hardware flow control, but enable communication.
- When the connector of an external device is a D-sub 9-pin connector, pin 7 is RTS and pin 8 is CTS.
- When the AX-KO3285-320 cable is used, RTS and CTS are internally connected and the above operation is unnecessary.

14.5. HVW-04CWP Comparator Relay Output / Buzzer

Relay output maximum rating is as follows:

Maximum voltage: 50V DC

Maximum current: 100mA DC

Maximum ON resistance: 8Ω

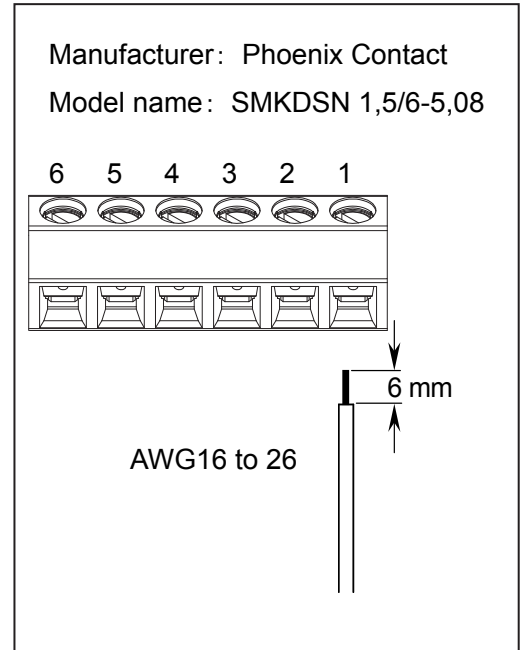
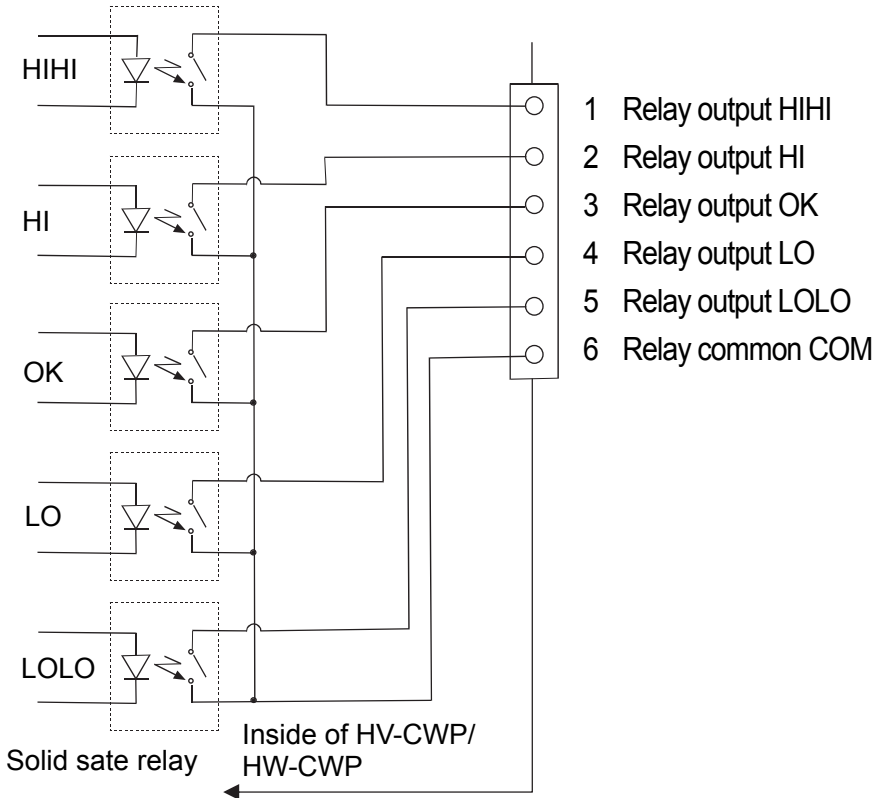

Caution

When the three-level comparator mode is used, the comparator outputs are the HIHI 1pin, OK 3 pin and LOLO 5 pin. HI 2 pin and LO 4 pin are not used.

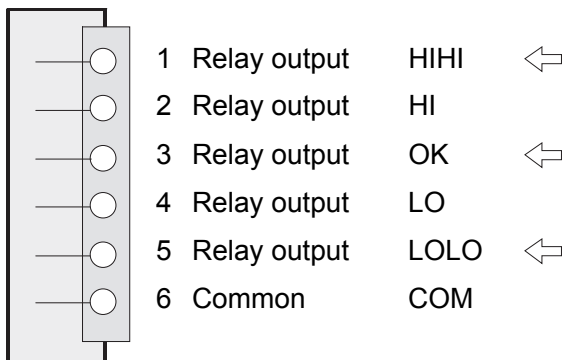

Buzzer

- Buzzer acoustic pressure level Approx.48 [dB/1m]

The buzzer is mounted on the electrical circuit board of the HVW-04CWP.

The buzzer can sound with LED (at upper side of the display) that is synchronized to a comparator result. The use of the buzzer can specify at

h	l	l	l	l	l
---	---	---	---	---	---

 of the function table.

Refer to "10.4. Buzzer Setting".

14.6. Communication Format

Data Format

S	T	,	+	0	0	0	0	0	.	0	0	_	k	g	C _R	L _F
---	---	---	---	---	---	---	---	---	---	---	---	---	---	---	----------------	----------------

Header

Data

Unit

Terminator

- There are 4 headers for the weighing data.

ST: Stable weighing data
 QT: Stable counting data
 US: Unstable weighing data
 OL: Out of weighing range

- The data consists of 9 characters including the polarity and decimal point.

- The weighing units are as follows. _ means "Space (20h)".

_ k g: Weighing mode "kg"
 _ l b: Weighing mode "lb"
 _ o z: Weighing mode "oz"
 _ PC: Counting mode "pcs"

- As a terminator, C_{RLF} is always output. C_R : 0Dh, L_F : 0Ah

- Data example

Weighing data "kg" (+)	S T , + 0 0 1 2 . 3 4 5 _ k g C _R L _F
Counting data "pcs" (+)	Q T , + 0 0 0 1 2 3 4 5 _ P C C _R L _F
Out of weighing range (+)	O L , + 9 9 9 9 . 9 9 9 _ k g C _R L _F
HV-CWP model	S T , + 0 0 1 2 . 3 4 _ _ k g C _R L _F

When the position of the readability changes depending on the weighing range, the hidden digit is replaced to _.

- Example of tare function

When "tare data is output (

5	1
---	---

)" is specified in the parameter list, data is output.

Net	"kg" (+)	N _ , + 0 0 1 2 . 3 4 5 _ k g C _R L _F
Tare data	"kg"	T _ , + 0 0 0 2 . 0 0 0 _ k g C _R L _F

- Example of preset tare function

Net	"kg" (+)	N _ , + 0 0 1 2 . 3 4 5 _ k g C _R L _F
Preset tare data	"kg"	P T , + 0 0 0 2 . 0 0 0 _ k g C _R L _F

Data Output Mode (*Prt*)

Command mode

The scale is controlled by commands that come from an external device such as a personal computer. See "Command Mode" for details.

Stream mode (*Prt* | *0*)

Data is sent continuously. The data update rate is approximately 10 times per second, the same as the display refresh rate.
There will be no output during the setting procedures.

Print key mode (*Prt* | *4*)

When the weight display is stable, data is sent by pressing the **PRINT** key.
At this time, the display flashes once to indicate that the data is sent.

Auto-print mode + data (*Prt* | *5*)

When the weight display is stable at +5d (d = readability(scale interval or "division")) and above, the data is sent.
The next transmission can not occur until after the weight display falls to +4d or below.

Auto-print mode +/- data (*Prt* | *6*)

When the weight display is stable at $\pm 5d$ (d = readability(scale interval or "division")) and above +5d or below -5d, the data is sent. The next transmission can not occur until after the weight display falls between -4d and +4d.

Auto-print mode + data and OK (*Prt* | *7*)

When the weight display is stable and OK as a comparison result at +5d (d = readability(scale interval or "division")) and above, the data is sent. The next transmission can not occur until after the weight display falls +4d or below.

Auto-print mode +/- data and OK (*Prt* | *8*)

When the weight display is stable and OK as a comparison result at $\pm 5d$ (d = readability(scale interval or "division")) and above +5d or below -5d, the data is sent. The next transmission can not occur until after the weight display falls between -4d and +4d.

Baud Rate (*bP5*)

When using HVW-03CWP, select the baud rate according to the device to be connected.

2400 bps (*bP5* | *0*) Select 2400 bps to connect to an AD-8121B printer.

4800 bps (*bP5* | *1*)

9600 bps (*bP5* | *2*)

Command Mode

In the command mode, the scale is controlled by commands that come from an external device such as a personal computer.

Command List

Command	Description	Remarks
Q	Requests data be output immediately.	
Z	Zeros the scale when the weight is stable.	Same as the ZERO key.
T	Tares the scale when the weight is stable.	Same as the TARE key.
U	Switches the weighing unit.	Same as the MODE key.
CT	Clears tare	
PT	Sets preset tare	PT,+000000<CR><LF>
A	Outputs accumulation values	
N	Outputs the number of accumulations	
CA	Clears accumulation	
ID	Sets the ID number	ID: xxxxxx<CR><LF>
?ID	Requests ID number	
?PT	Outputs the preset tare value	
?H3	In five-level comparator mode: Not used. In three-level comparator mode: Not used. In seven-level comparator mode: Threshold value of rank 5 is output.	The output of setting values for comparator mode Five-level ([P-L 0]) Three-level ([P-L 1]) Seven-level ([P-L 2])
?H2	In five-level comparator mode: HHI limit value is output. In three-level comparator mode: HI limit value is output. In seven-level comparator mode: Threshold value of rank 4 is output.	
?H1	In five-level comparator mode: HI limit value is output. In three-level comparator mode: Not used. In seven-level comparator mode: Upper threshold value of rank 3 is output.	
?L1	In five-level comparator mode: LO limit value is output. In three-level comparator mode: Not used. In seven-level comparator mode: Lower threshold value of rank 3 is output.	
?L2	In five-level comparator mode: LOLO limit value is output. In three-level comparator mode: LO limit value is output. In seven-level comparator mode: Threshold value of rank 2 is output.	
		The output of setting values for

Command	Description	Remarks
?L3	In five-level comparator mode: Not used. In three-level comparator mode: Not used. In seven-level comparator mode: Threshold value of rank 1 is output.	comparator mode Five-level ($\boxed{[P-L \ 0]}$) Three-level ($\boxed{[P-L \ 1]}$) Seven-level ($\boxed{[P-L \ 2]}$)
H3	In five-level comparator mode: Not used. In three-level comparator mode: Not used. In seven-level comparator mode: The threshold value of rank 5 is stored.	Set the six-digit value excluding the polarity and decimal point
H2	In five-level comparator mode: HHI limit value is stored. In three-level comparator mode: HI limit value is stored. In seven-level comparator mode: The threshold value of rank 4 is stored.	
H1	In five-level comparator mode: HI limit value is stored. In three-level comparator mode: Not used. In seven-level comparator mode: The upper threshold value of rank 3 is stored.	
L1	In five-level comparator mode: LO limit value is stored. In three-level comparator mode: Not used. In seven-level comparator mode: The lower threshold value of rank 3 is stored.	
L2	In five-level comparator mode: LOLO limit value is stored. In three-level comparator mode: LO limit value is stored. In seven-level comparator mode: The threshold value of rank 2 is stored.	
L3	In five-level comparator mode: Not used. In three-level comparator mode: Not used. In seven-level comparator mode: The threshold value of rank 1 is stored.	

Command Examples

The examples below are for the function setting

S	F	1	1
---	---	---	---

 (Reply to commands).
The character `␣` means "Space (20h)".

To request data be output immediately

Command	Q	C _R	L _F																
Reply	S	T	,	+	0	0	1	2	.	3	4	5	␣	k	g	C _R	L _F	Stable positive data	
	U	S	,	+	0	0	0	7	.	8	9	0	␣	k	g	C _R	L _F	Unstable positive data	
	O	L	,	+	9	9	9	9	.	9	9	9	␣	k	g	C _R	L _F	<table border="1" style="display: inline-table; vertical-align: middle;"><tr><td>E</td></tr></table> display	E
E																			

To zero the weighing value when the weighing value is stable

Zero point is set when the scale is in a condition where zero operation is possible.

Command	Z	C _R	L _F																			
Reply	Z	C _R	L _F	Zero point has been set. (No reply If <table border="1" style="display: inline-table; vertical-align: middle;"><tr><td>S</td><td>F</td><td>1</td><td>0</td></tr></table> is set.)															S	F	1	0
S	F	1	0																			

To tare the weighing value when the weighing value is stable

Net value is displayed when the scale is in a condition where tare operation is possible.

Command	T	C _R	L _F																			
Reply	T	C _R	L _F	Net value has been displayed. (No reply If <table border="1" style="display: inline-table; vertical-align: middle;"><tr><td>S</td><td>F</td><td>1</td><td>0</td></tr></table> is set.)															S	F	1	0
S	F	1	0																			

To switch the weighing unit

The weighing unit is switched.

Command	U	C _R	L _F																			
Reply	U	C _R	L _F	No reply If <table border="1" style="display: inline-table; vertical-align: middle;"><tr><td>S</td><td>F</td><td>1</td><td>0</td></tr></table> is set.															S	F	1	0
S	F	1	0																			

To cancel tare value

The weighing value becomes the gross and the net indicator is turned off. The tare value becomes zero.

Command	C	T	C _R	L _F															
Reply	C	T	C _R	L _F	This command has been executed.														

To set preset tare

Tare value is set and the net is displayed. Tare value is a numerical value of 6 digits with a polarity sign and does not contain a decimal point.

Template	P	T	, [parameter]																						
Command	P	T	,	+	0	0	0	1	2	0	C _R	L _F													
Reply	P	T	,	+	0	0	0	1	2	0	C _R	L _F													

To output accumulation values

Command

A	C _R	L _F
---	----------------	----------------

 Reply

A	,	+	0	0	1	2	.	3	0	0	␣	k	g	C _R	L _F
---	---	---	---	---	---	---	---	---	---	---	---	---	---	----------------	----------------

To output the number of accumulations

Command

N	C _R	L _F
---	----------------	----------------

 Reply

N	,	+	0	0	0	0	0	1	4	0	␣	␣	␣	C _R	L _F
---	---	---	---	---	---	---	---	---	---	---	---	---	---	----------------	----------------

To clear accumulation

Accumulated data and number of accumulations are set to zero.

Command

C	A	C _R	L _F
---	---	----------------	----------------

 Reply

C	A	C _R	L _F
---	---	----------------	----------------

To set ID number

ID number is numerical value and alphabet characters of 6 digits and does not contain a decimal point.

Template

I	D
---	---

 : [parameter]
 Command

I	D	:	A	B	C	1	2	3	C _R	L _F
---	---	---	---	---	---	---	---	---	----------------	----------------

 Reply

I	D	:	A	B	C	1	2	3	C _R	L _F
---	---	---	---	---	---	---	---	---	----------------	----------------

To request ID number

ID number is output.

Command

?	I	D	C _R	L _F
---	---	---	----------------	----------------

 Reply

I	D	:	A	B	C	1	2	3	C _R	L _F
---	---	---	---	---	---	---	---	---	----------------	----------------

To output preset tare value

Preset tare value is output.

Command

?	P	T	C _R	L _F
---	---	---	----------------	----------------

 Reply

P	T	,	+	0	0	0	0	,	1	2	0	␣	k	g	C _R	L _F
---	---	---	---	---	---	---	---	---	---	---	---	---	---	---	----------------	----------------

To output H3 value

Five-level comparator mode Not used

Three-level comparator mode..... Not used

Seven-level comparator mode Threshold value of rank 5 is output.

Command

?	H	3	C _R	L _F
---	---	---	----------------	----------------

 Reply

H	3	,	+	0	0	0	5	0	0	C _R	L _F
---	---	---	---	---	---	---	---	---	---	----------------	----------------

To output H2 value

Five-level comparator mode HIHI limit value is output.

Three-level comparator mode..... HI limit value is output.

Seven-level comparator mode Threshold value of rank 4 is output.

Command

?	H	2	C _R	L _F
---	---	---	----------------	----------------

Reply

H	2	,	+	0	0	0	4	0	0	C _R	L _F
---	---	---	---	---	---	---	---	---	---	----------------	----------------

To output H1 value

Five-level comparator mode HI limit value is output.

Three-level comparator mode..... Not used

Seven-level comparator mode Upper threshold value of rank 3 is output.

Command

?	H	1	C _R	L _F
---	---	---	----------------	----------------

Reply

H	1	,	+	0	0	0	3	0	0	C _R	L _F
---	---	---	---	---	---	---	---	---	---	----------------	----------------

To output L1 value

Five-level comparator mode LO limit value is output.

Three-level comparator mode..... Not used

Seven-level comparator mode Lower threshold value of rank 3 is output.

Command

?	L	1	C _R	L _F
---	---	---	----------------	----------------

Reply

L	1	,	+	0	0	0	2	0	0	C _R	L _F
---	---	---	---	---	---	---	---	---	---	----------------	----------------

To output L2 value

Five-level comparator mode LOLO limit value is output.

Three-level comparator mode..... LO limit value is output.

Seven-level comparator mode Threshold value of rank 2 is output.

Command

?	L	2	C _R	L _F
---	---	---	----------------	----------------

Reply

L	2	,	+	0	0	0	1	0	0	C _R	L _F
---	---	---	---	---	---	---	---	---	---	----------------	----------------

To output L3 value

Five-level comparator mode Not used

Three-level comparator mode..... Not used

Seven-level comparator mode Threshold value of rank 1 is output.

Command

?	L	3	C _R	L _F
---	---	---	----------------	----------------

Reply

L	3	,	+	0	0	0	0	0	0	C _R	L _F
---	---	---	---	---	---	---	---	---	---	----------------	----------------

To set H3 value

Five-level comparator mode Not used

Three-level comparator mode..... Not used

Seven-level comparator mode Threshold value of rank 5 is stored.

Input the parameter of 6 digits excluding the decimal point.

Template	H	3	,	[parameter]								
Command	H	3	,	+	0	0	0	5	0	0	C _R	L _F
Reply	H	3	,	+	0	0	0	5	0	0	C _R	L _F

No reply If

S	F	1	0
---	---	---	---

 is set.

To set H2 value

Five-level comparator mode HIHI limit value is stored.

Three-level comparator mode HI limit value is stored.

Seven-level comparator mode Threshold value of rank 4 is stored.

Input the parameter of 6 digits excluding the decimal point.

Template	H	2	,	[parameter]								
Command	H	2	,	+	0	0	0	4	0	0	C _R	L _F
Reply	H	2	,	+	0	0	0	4	0	0	C _R	L _F

No reply If

S	F	1	0
---	---	---	---

 is set.

To set H1 value

Five-level comparator mode HI limit value is stored.

Three-level comparator mode Not used

Seven-level comparator mode Upper Threshold value of rank 3 is stored.

Input the parameter of 6 digits excluding the decimal point.

Template	H	1	,	[parameter]								
Command	H	1	,	+	0	0	0	3	0	0	C _R	L _F
Reply	H	1	,	+	0	0	0	3	0	0	C _R	L _F

No reply If

S	F	1	0
---	---	---	---

 is set.

To set L1 value

Five-level comparator mode LO limit value is stored.

Three-level comparator mode Not used

Seven-level comparator mode Lower threshold value of rank 3 is stored.

Input the parameter of 6 digits excluding the decimal point.

Template	L	1	,	[parameter]								
Command	L	1	,	+	0	0	0	2	0	0	C _R	L _F
Reply	L	1	,	+	0	0	0	2	0	0	C _R	L _F

No reply If

S	F	1	0
---	---	---	---

 is set.

To set L2 value

Five-level comparator mode LOLO limit value is stored.

Three-level comparator mode LO limit value is stored.

Seven-level comparator mode Threshold value of rank 2 is stored.

Input the parameter of 6 digits excluding the decimal point.

Template	L	2	,	[parameter]								
Command	L	2	,	+	0	0	0	1	0	0	C _R	L _F
Reply	L	2	,	+	0	0	0	1	0	0	C _R	L _F

No reply If

S	I	F	0
---	---	---	---

 is set.

To set L3 value

Five-level comparator mode Not used
 Three-level comparator mode..... Not used
 Seven-level comparator mode..... Threshold value of rank 1 is stored.
 Input the parameter of 6 digits excluding the decimal point.

Template	L	3	,	[parameter]								
Command	L	3	,	+	0	0	0	0	0	0	C _R	L _F
Reply	L	3	,	+	0	0	0	0	0	0	C _R	L _F

No reply If

S	I	F	0
---	---	---	---

 is set.

**Response when

S	I	F	1
---	---	---	---

 is specified in the function table**

If

S	I	F	1
---	---	---	---

 is used and a command response is active, the following response may be output.

- When the

Z

 command is executed with an unstable weighing value and cannot be finished, the response

I

 is returned.

Command	Z	C _R	L _F
Reply	I	C _R	L _F

The scale is not in a condition that zero operation is possible.

- When the scale receives a command that it cannot identify or that does not exist, the response

?

 is returned.

Command	B	C _R	L _F
Reply	?	C _R	L _F

The scale received an undefined command.

**Response when

S	I	F	0
---	---	---	---

 is specified in the function table**

- | | | | |
|---|---|---|---|
| S | I | F | 0 |
|---|---|---|---|

 does not use a reply. The undefined command is ignored.

14.7. Using UFC (Universal Flex Coms) Function

- The UFC function allows you to print out using the format enabled for the printer (UFC format). The UFC format data can be output through an RS-232C or USB interface.
- The scale can store the UFC format as text data. The format can use variable parameters as a part of text data. Variable parameters can replace with weighing value, tare value and the like when printed out.

- The maximum number of text data is 400 characters.
- To use the UFC function, it is necessary that the **[PF]** command be used and the UFC format be stored as text data in the scale in advance.
- When the **[PRINT]** key is pressed or auto-print mode is used, the scale prints the stored text data after variable parameters is replaced with weighing value, tare value and the like.
- Specify **[5, F 1 2]** to use the UFC format in the function table.

Store Text Data to the Scale

Command	P	F	,	\$	P	C	,	'	T	E	X	T	'	,	#	2	0	,	\$	S	P	*	2
	,	&	\$	C	R	,	\$	L	F	,	\$	W	T	,	\$	C	R	,	\$	L	F	C _R	L _F
Reply	P	F	C _R	L _F	Terminator																		

The text data (the UFC format) can sent using the **[PF]** command:

- Variable parameters for the scale data and control codes

Parameter	Scale Data & Control Code	Parameter	Scale Data & Control Code
\$ID	ID number	\$AN	Accumulation counts
\$PC	Counting number	\$CP	Comparator result
\$WT	Current weighing value	\$CM	, Comma (2Ch)
\$TR	Current tare value	\$CR	C _R Carriage Return (0Dh)
\$PT	Current preset tare value	\$LF	L _F Line Feed (0Ah)
\$TL	Accumulation value	\$SP	␣ Space (20h)

Note

⚠ These parameters must use capital letters.

- ASCII text string

Text string is described in single quote marks **[']**.

The single quote itself is written as two single quotes.

Example of text *Data* : **'Data'**

Example of text *'Data'* : **'"Data"'**

- The ASCII hexadecimal code

The ASCII hexadecimal codes are written in the form **[#]** and two hexadecimal digits.

This will mainly be used to send control codes that cannot be described as a text string.

Example of **[EOT]** of ASCII code : **#04**

- Data repeated

When the control codes \$SP, \$CR and \$LF can be used with "***** and number (of two digits in maximum)", these codes will be repeated the number of times designated.

Example where \$LF is repeated 9 times : \$LF*9

Example where space is repeated 12 times : \$SP*12

□ Link mark

If you will send more than 2 lines of data, attach to the end of the first line. Then, the scale decides that the data is continued.

□ As separators for data, a space (20h) or comma (2Ch) are used.

These separators can be omitted, but you cannot omit the comma (2Ch) after the command. You must start with the command.

□ Data format for variable parameters is used space (20h) is expressed as .

Variable parameters of the scale data are replaced with the following data format :

□ Data is a fixed length that includes a sign and a decimal point.

The leading zeros of data are replaced with spaces (20h) .

\$ID of variable parameter

Example of ID number : ABC456

6 digits

A	B	C	4	5	6
---	---	---	---	---	---

\$PC of variable parameter

Example of counting number : 123 pcs

9 digit counting number + 3 digit unit

<input style="width: 20px;" type="text" value=" "/>	<input style="width: 20px;" type="text" value=" "/>	<input style="width: 20px;" type="text" value=" "/>	<input style="width: 20px;" type="text" value=" "/>	<input style="width: 20px;" type="text" value=" "/>	+	1	2	3	<input style="width: 20px;" type="text" value=" "/>	P	C
---	---	---	---	---	---	---	---	---	---	---	---

\$WT of variable parameter

Example of the current weighing value : 1.234 kg

9 digit weighing value + 3 digit unit

<input style="width: 20px;" type="text" value=" "/>	<input style="width: 20px;" type="text" value=" "/>	<input style="width: 20px;" type="text" value=" "/>	+	1	.	2	3	4	<input style="width: 20px;" type="text" value=" "/>	k	g
---	---	---	---	---	---	---	---	---	---	---	---

\$TR of variable parameters

Example of the current tare value : 1.234 kg

9 digit tare value + 3 digit unit

<input style="width: 20px;" type="text" value=" "/>	<input style="width: 20px;" type="text" value=" "/>	<input style="width: 20px;" type="text" value=" "/>	+	1	.	2	3	4	<input style="width: 20px;" type="text" value=" "/>	k	g
---	---	---	---	---	---	---	---	---	---	---	---

\$PT of variable parameter

Example of the current preset tare value : 1.234 kg

9 digit preset tare value + 3 digit unit

<input style="width: 20px;" type="text" value=" "/>	<input style="width: 20px;" type="text" value=" "/>	<input style="width: 20px;" type="text" value=" "/>	+	1	.	2	3	4	<input style="width: 20px;" type="text" value=" "/>	k	g
---	---	---	---	---	---	---	---	---	---	---	---

\$TL of variable parameter

Example of accumulation value : 1.234 kg

9 digit accumulation value + 3 digit unit

□ □ □ + 1 . 2 3 4 □ k g

\$AN of variable parameter

Example of accumulation count : 123 counts

9 digit accumulation count

□ □ □ □ □ + 1 2 3

\$CP of variable parameter

Example of HHI result

3 digits

H I 2

Example of HI result

3 digits

H I 1

Example of OK result

2 digits

O K

Example of LO result

3 digits

L O 1

Example of LOLO result

3 digits

L O 2

Example of "not compared"

2 digits

□ □

Printing Example for the PF Command using the AD-8127 Printer

AD-8127 format for

5.12

Weight +1.234 kg
CHECK
OK

The PF Command

PC → Scale

PF, 'Weight', \$CR, \$LF, &
\$SP * 4, \$WT, \$CR, \$LF, &
'CHECK' \$CR, \$LF, &
\$SP * 4, \$CP, \$CR, \$LF, &
\$CR, \$LF C_R L_F

Terminator code

\$CR : Carriage return, ASCII 0Dh

\$LF : Line feed, ASCII 0Ah

Note

⚠ The UFC format does not send a terminator code automatically.

Therefore, add the terminator code at the end of text data if necessary.



15. ID Number and GMP, GLP

The ID number is used to identify the scale when Good Manufacturing Practice (GMP) or Good Laboratory Practice (GLP) is used. Using the optional HVW-02BCWP USB interface or optional HVW-03CWP RS-232C serial interface, the data corresponding to the following GMP or GLP can be output to a printer or PC.

- Results of calibration (“Calibration Report”)
- Results of calibration test (“Calibration Test Report”)
- “Start Block” and “End Block” for GMP, GLP data

15.1. Setting the ID Number

Step 1 With the display turned off, while pressing and holding the **TARE** key, press the **ON/OFF** key to turn the display on and enter the function setting mode.

bASFnC appears.

Step 2 Press the **MODE** key several times to display **id**.

Step 3 Press the **ENTER** key.

Enter the ID number using the following keys.

M+ : To move the blinking digit to the left

PRINT : To move the blinking digit to the right

Numerical keypad : To set a value for the blinking digit
See the table below for the “Display Character Table.”

Step 4 Press the **ENTER** key to store the setting.

id appears after **End**.

Step 5 Press the **ON/OFF** key to turn the display OFF or press the **ZERO** key.

bASFnC

Press several times **MODE**

id

ENTER

000000

Set using corresponding keys.

ENTER

End

id

Display Character Table

0	1	2	3	4	5	6	7	8	9	-	□	A	B	C	D	E	F	G	H	I	J	K	L	M	N	O	P	Q	R	S	T	U	V	W	X	Y	Z
0	1	2	3	4	5	6	7	8	9	-	□	A	b	C	d	E	F	G	H	I	J	K	L	M	N	O	P	Q	R	S	T	U	V	W	X	Y	Z

“□” : Space, ASCII 20h

15.2. GMP, GLP Report

- To print the GMP or GLP report to AD-8121B or AD-8127 printer, select the function setting `inF1 1` and set the AD-8121B to MODE 3 and the AD-8127 to dump print mode (DUMP).
- To output the GMP, GLP report to a personal computer, select the function setting `inF1 2`.

Calibration Report

- Step 1 Perform calibration according to “12.1. Procedure for the Calibration”.
- Step 2 `End` appears when calibration is complete.
- Step 3 `GNP` appears and the calibration report is output.
- Step 4 `CAL` appears again. Remove the weight. Press the `ON/OFF` key to turn the display OFF or press the `CAL` switch.

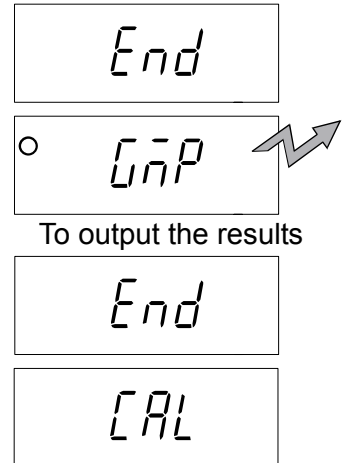

AD-8121B, AD-8127 format `inF1 1`

General format `inF1 2`

```

      A & D
MODEL  HV-15KCWP
S/N    6A6123456
ID     ABCDEF
DATE   2014/04/01
TIME   16:47:39
CALIBRATED(EXT.)
CAL.WEIGHT
      +15.000 kg
SIGNATURE
-----

```

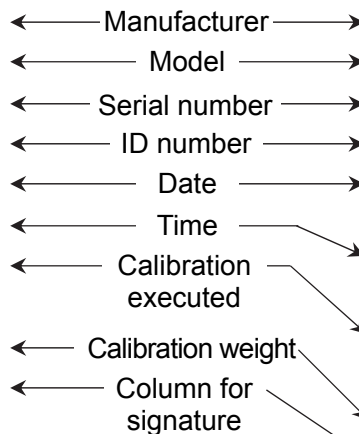

```

_____A_&_D<CRLF>
MODEL__HV-15KCWP<CRLF>
S/N____6A6123456<CRLF>
ID_____ABCDEF<CRLF>
DATE<CRLF>
<CRLF>
TIME<CRLF>
<CRLF>
CALIBRATED(EXT.)<CRLF>
CAL.WEIGHT<CRLF>
_____+15.000_kg<CRLF>
SIGNATURE<CRLF>
<CRLF>
<CRLF>
-----<CRLF>
<CRLF>
<CRLF>

```

- ␣ : Space, ASCII 20h
- CR: Carriage return, ASCII 0Dh
- LF: Line feed, ASCII 0Ah

Calibration Test Report

The calibration test mode is used to compare a calibration weight with the calibration test data weighed by the scale.

- ❑ This test does not perform calibration.

Step 1 In the weighing mode, press and hold the **CAL** switch until **[[** appears, and then release the switch, or, press and hold the **C** key for five seconds until **[[** appears and release the key.

- ❑ The calibration test mode is not available when the function setting **INF 0** is selected.

Step 2 Press the **ENTER** key to display **[[0**.

Step 3 Change the calibration weight value if necessary.
To change the calibration weight value, press the **MODE** key.
Change the value using the following keys.

Numerical keypad Enter the value.

ENTER key Register the value and return to Step 2.

ZERO key Cancel the settings without changing the parameter and return to Step 2.

Step 4 With nothing on the weighing pan, press the **ENTER** key.

The zero point is measured and the weighing value with the unit “kg” is displayed for a few seconds. Then, the value of the calibration weight is displayed.

Step 5 Place a calibration weight of the same value as displayed on the weighing pan and press the **ENTER** key to measure it.

The measured value with the unit “kg” is displayed for a few seconds.

Step 6 **End** appears.

Step 7 **UnP** appears and the calibration test report is output.

Step 8 **[[** appears again. Remove the weight.
Press the **ON/OFF** key to turn the display OFF or press the **CAL** switch.

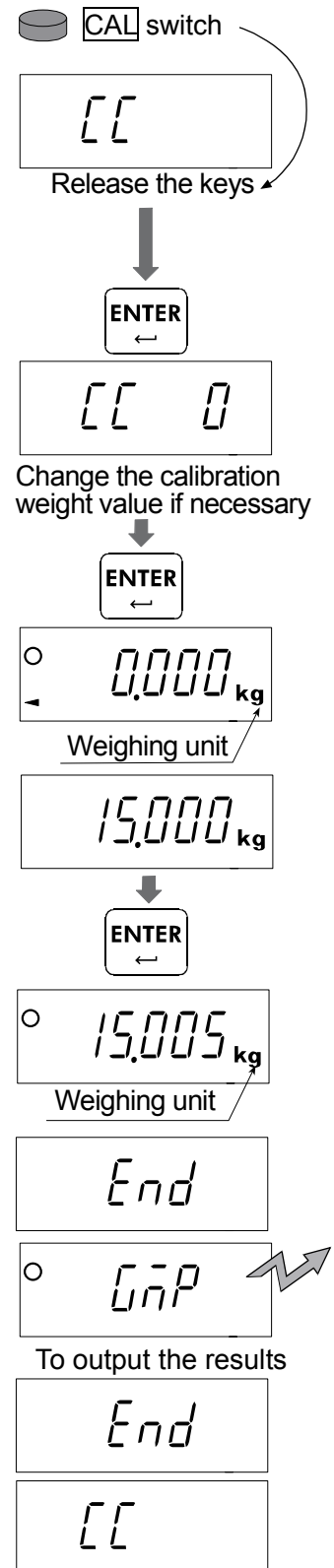

AD-8121B, AD-8127 format inf 1

```

                A & D
MODEL  HV-15KCWP
S/N    6A6123456
ID     ABCDEF
DATE   2014/04/01
TIME   17:05:02
CAL.TEST(EXT.)
ACTUAL
        0.000 kg
        +15.005 kg
TARGET
        +15.000 kg
SIGNATURE
-----
    
```

- ← Manufacturer →
- ← Model →
- ← Serial number →
- ← ID number →
- ← Date →
- ← Time →
- ← Calibration test →
- ← Zero value →
- ← Actual weight value →
- ← Calibration weight →
- ← Column for signature →

General format inf 2

```

                A_&_D<CRLF>
MODEL__HV-15KCWP<CRLF>
S/N_____6A6123456<CRLF>
ID_____ABCDEF<CRLF>
DATE<CRLF>
<CRLF>
TIME<CRLF>
<CRLF>
CAL.TEST(EXT.)<CRLF>
ACTUAL<CRLF>
        _0.000_kg<CRLF>
        _+15.005_kg<CRLF>
TARGET<CRLF>
        _+15.000_kg<CRLF>
SIGNATURE<CRLF>
<CRLF>
<CRLF>
----- <CRLF>
<CRLF>
<CRLF>
    
```

_ : Space, ASCII 20h
 CR: Carriage return, ASCII 0Dh
 LF: Line feed, ASCII 0Ah

Output of "Title Block" and "End Block"

When weighing values are recorded as the GMP, GLP report, "Title Block" and "End Block" are added at the beginning and at the end of a group of weight values.

Title Block

Step 1 In the weighing mode, press and hold the **PRINT** key until **StArT** appears, and then release the key. The scale outputs the "Title Block." The scale automatically returns to the weighing mode.

Step 2 Press the **PRINT** key or select the auto-print mode to output the weight values.

End Block

Step 3 Press and hold the **PRINT** key until **rEcEnd** appears, and then release the key. The scale outputs the "End Block."

Step 4 The scale automatically returns to the weighing mode.

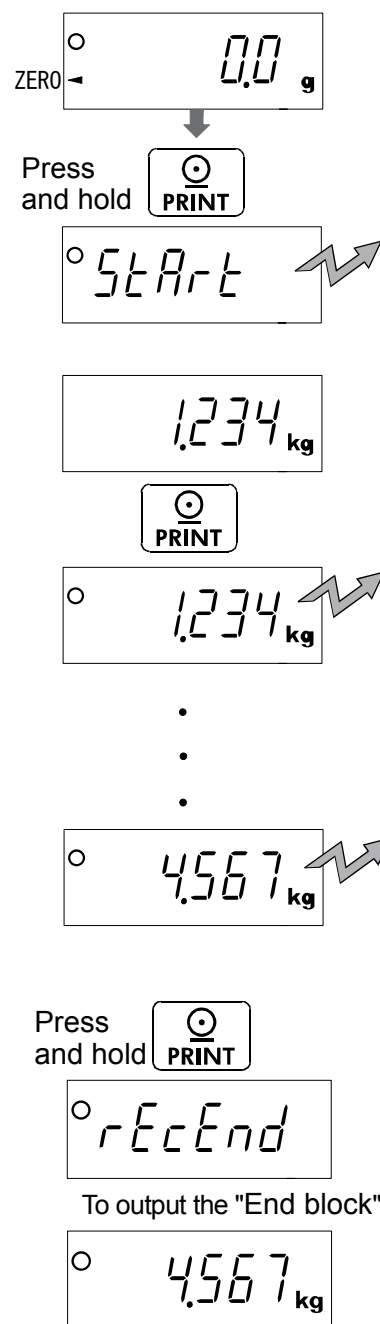

AD-8121B, AD-8127 format inF11

General format inF12

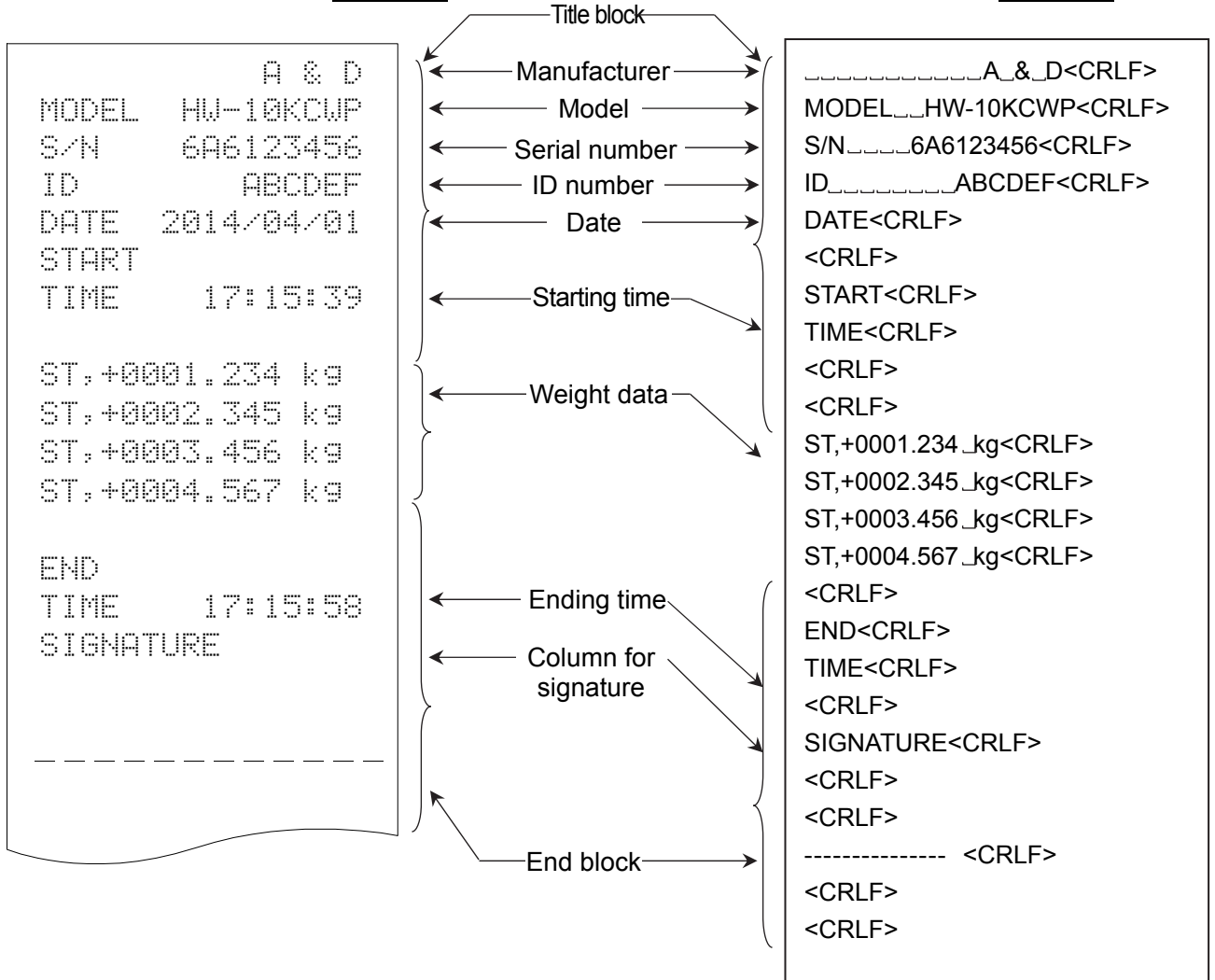

␣ : Space, ASCII 20h
CR: Carriage return, ASCII 0Dh
LF: Line feed, ASCII 0Ah



16. Maintenance

- Refer to "4. Cautions" regarding use.
- Refer to "16.2. Check Points Before Calling Maintenance Service" and corresponding mode for displayed error code.
- Refer to "12. Calibration" regarding precision weighing.
- Periodically check the accuracy of weighing. Calibrate the scale, if it is moved to another location or the environment has changed.

16.1. Repair

Do not disassemble / assemble the scale without an authorized service engineer. Doing so may cause an electric shock or damage to the scale, etc. In this case, repair is not covered under warranty. Contact your local A&D dealer if your scale needs service or repair.

16.2. Check Points Before Calling Maintenance Service

In this situation	Confirm these items
Nothing displayed. Scale does not turn on.	<input type="checkbox"/> Is the main power cord properly connected? <input type="checkbox"/> Is the main power the correct voltage?
The scale does not display zero at first.	<input type="checkbox"/> Check around the weighing pan. <input type="checkbox"/> Is there anything on the weighing pan? <input type="checkbox"/> Perform zero point calibration.
<div style="border: 1px solid black; display: inline-block; padding: 2px;">-----</div> is displayed and does not proceed.	<input type="checkbox"/> The weighing value is unstable due to drift, vibration or other factors. A breeze or vibration may be affecting the measurement. Check around the weighing pan. <input type="checkbox"/> Check the connection of load cell cable. <input type="checkbox"/> No zero display when the display is turned on. Remove anything that is on the pan. <input type="checkbox"/> Perform zero point calibration.
<div style="border: 1px solid black; display: inline-block; padding: 2px;">EAL E</div> is displayed.	<input type="checkbox"/> Calibration error that meaning "Too heavy."
<div style="border: 1px solid black; display: inline-block; padding: 2px;">-EAL E</div> is displayed.	<input type="checkbox"/> Calibration error that meaning "Too light."
<div style="border: 1px solid black; display: inline-block; padding: 2px;">E</div> is displayed.	<input type="checkbox"/> Weighing error that meaning "Over loaded."
<div style="border: 1px solid black; display: inline-block; padding: 2px;">-E</div> is displayed.	<input type="checkbox"/> Weighing error that meaning "Under loaded."
Fixed display.	<input type="checkbox"/> Did you use the "hold function" ? <input type="checkbox"/> Turn off scale and turn it on again.

When the following error is displayed, shutdown the power once and turn the power on again. If you cannot cope with this error, contact your local dealer.

<div style="border: 1px solid black; display: inline-block; padding: 2px;">Err 1</div> is displayed	<input type="checkbox"/> Mass sensor failed.
<div style="border: 1px solid black; display: inline-block; padding: 2px;">Err 2</div> is displayed	<input type="checkbox"/> Temperature sensor failed.
<div style="border: 1px solid black; display: inline-block; padding: 2px;">Err 3</div> is displayed	<input type="checkbox"/> Memory (circuit) failed.



17. Specifications

HV-CWP Series

Models	HV-15KCWP			HV-60KCWP			HV-200KCWP		
Weighing Capacity [kg]	3	6	15	15	30	60	60	150	220
Readability [kg]	0.001	0.002	0.005	0.005	0.01	0.02	0.02	0.05	0.1
Weighing Capacity [lb] #	6	15	30	30	60	150	150	300	500
Readability [lb] #	0.002	0.005	0.01	0.01	0.02	0.05	0.05	0.1	0.2
Weighing Capacity [oz] #	96	240	480	480	960	2400	2400	4800	8000
Readability [oz] #	0.05	0.1	0.2	0.2	0.5	1	1	2	5
Weighing Capacity [lb oz] #	30 lb			-					
Readability [lb oz] #	0.1 oz								
Number of Samples	5 pcs (can be changed 10 pcs , 20 pcs, 50 pcs and 100 pcs)								
Maximum Count Number	150,000 pcs			120,000 pcs			110,000 pcs		
Display	7 segment LCD with backlight (Character height 26 mm) 3 color 5 level comparator LED								
Repeatability(StandardDeviation) [kg]	0.001	0.002	0.005	0.005	0.01	0.02	0.02	0.05	0.1
Linearity [kg]	±0.001	±0.002	±0.005	±0.005	±0.01	±0.02	±0.02	±0.05	±0.1
Span Drift	±20 ppm/°C typ. (5°C to 35°C)								
Power Supply	AC main (100V to 240V)								
Ambient Temperature and Humidity	-10°C to 40°C, Less than 85%R.H. (Do not allow condensation)								
Weighing Pan Size [mm]	250 x 250			330 x 424			390 x 530		
Dimension [mm] Width x Depth x Height	250 x 470 x 430			330 x 616 x 752			390 x 722 x 752		
Weight	Approx. 8 kg			Approx. 12 kg			Approx. 19 kg		

#: If the law in your area allows, you can use these units.

HW-CWP Series

Models	HW-10KCWP	HW-60KCWP	HW-100KCWP	HW-200KCWP
Weighing Capacity [kg]	10	60	100	220
Readability [kg]	0.001	0.005	0.01	0.02
Weighing Capacity [lb] #	20	150	200	500
Readability [lb] #	0.002	0.01	0.02	0.05
Weighing Capacity [oz] #	320	2400	3200	8000
Readability [oz] #	0.05	0.2	0.5	1
Weighing Capacity [lb oz] #	20 lb	-		
Readability [lb oz] #	0.1 oz			
Number of Samples	5 pcs (can be changed 10 pcs , 20 pcs, 50 pcs and 100 pcs)			
Maximum Count Number	100,000 pcs	120,000 pcs	100,000 pcs	110,000 pcs
Display	7 segment LCD with backlight (Character height 26 mm) 3 color 5 level comparator LED			
Repeatability(StandardDeviation) [kg]	0.002	0.01	0.02	0.04
Linearity [kg]	±0.002	±0.01	±0.02	±0.04
Span Drift	±20 ppm/°C typ. (5°C to 35°C)			
Power Supply	AC main (100V to 240V)			
Ambient Temperature and Humidity	-10°C to 40°C, Less than 85%R.H. (Do not allow condensation)			
Weighing Pan Size [mm]	250 x 250	330 x 424	390 x 530	390 x 530
Dimension [mm] Width x Depth x Height	250 x 470 x 430	330 x 616 x 752	390 x 722 x 752	390 x 722 x 752
Weight	Approx. 8 kg	Approx. 12 kg	Approx. 19 kg	Approx. 19 kg

#: If the law in your area allows, you can use these units.

Dimensions

HV-15KCWP
HW-10KCWP

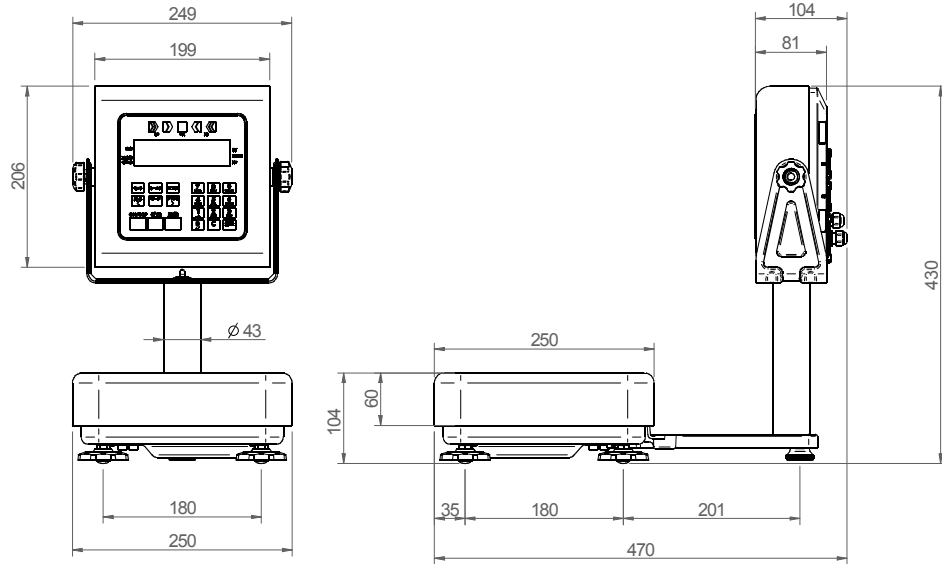

HV-60KCWP
HW-60KCWP

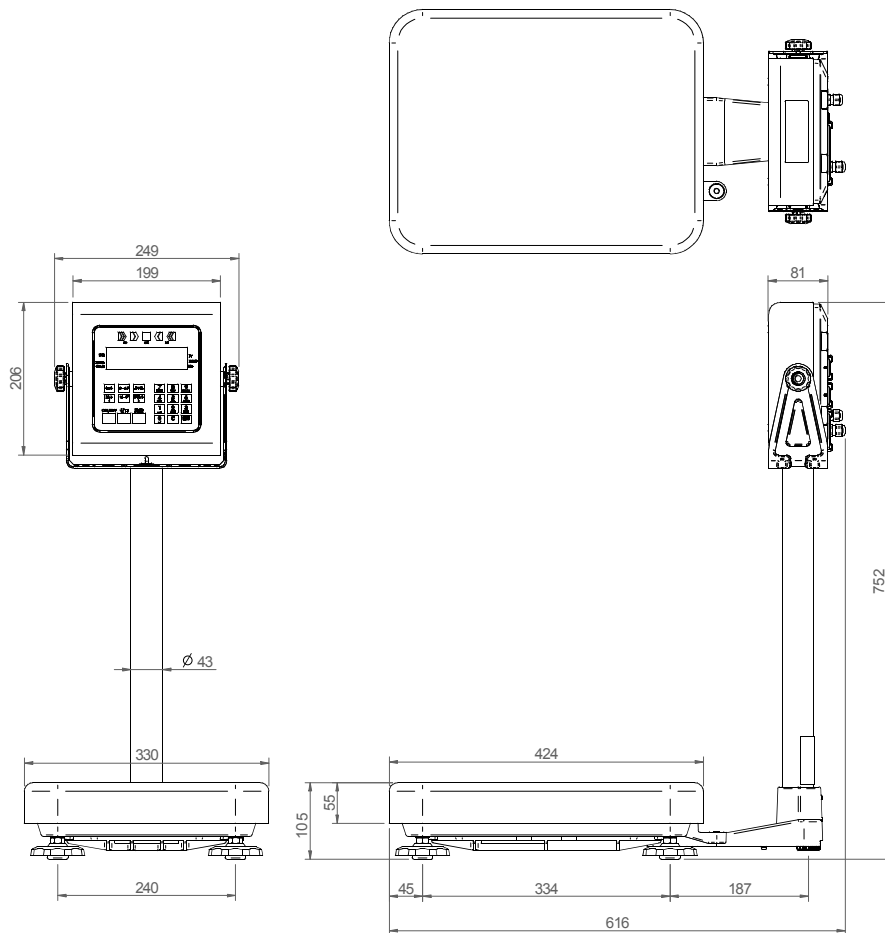

HV-200KCWP
HW-100KCWP
HW-200KCWP

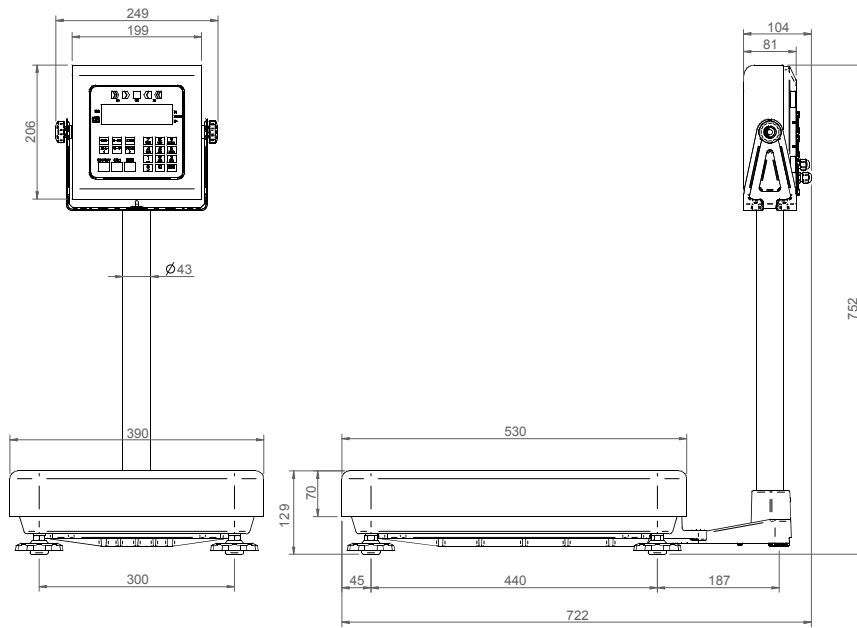
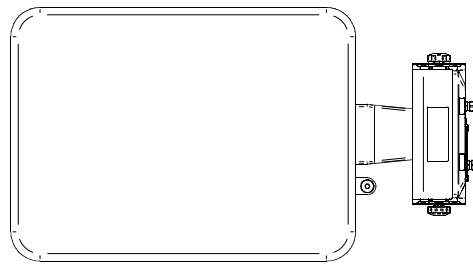

Gravity Acceleration Map

Values of gravity at various locations

Amsterdam	9.813 m/s ²	Manila	9.784 m/s ²
Athens	9.800 m/s ²	Melbourne	9.800 m/s ²
Auckland NZ	9.799 m/s ²	Mexico City	9.786 m/s ²
Bangkok	9.783 m/s ²	Milan	9.807 m/s ²
Birmingham	9.813 m/s ²	Moscow	9.816 m/s ²
Brussels	9.811 m/s ²	New York	9.802 m/s ²
Buenos Aires	9.797 m/s ²	Oslo	9.819 m/s ²
Cape Town	9.796 m/s ²	Ottawa	9.807 m/s ²
Chicago	9.803 m/s ²	Paris	9.810 m/s ²
Copenhagen	9.816 m/s ²	Rio de Janeiro	9.788 m/s ²
Cyprus	9.797 m/s ²	Rome	9.803 m/s ²
Frankfurt	9.811 m/s ²	San Francisco	9.800 m/s ²
Glasgow	9.816 m/s ²	Singapore	9.780 m/s ²
Havana	9.788 m/s ²	Stockholm	9.819 m/s ²
Helsinki	9.819 m/s ²	Sydney	9.796 m/s ²
Jakarta	9.781 m/s ²	Taichung	9.789 m/s ²
Kolkata (Calcutta)	9.788 m/s ²	Taipei	9.790 m/s ²
Kuwait	9.793 m/s ²	Tokyo	9.798 m/s ²
Lisbon	9.801 m/s ²	Vancouver, BC	9.810 m/s ²
London (Greenwich)	9.812 m/s ²	Washington DC	9.801 m/s ²
Los Angeles	9.797 m/s ²	Wellington NZ	9.803 m/s ²
Madrid	9.802 m/s ²	Zurich	9.808 m/s ²

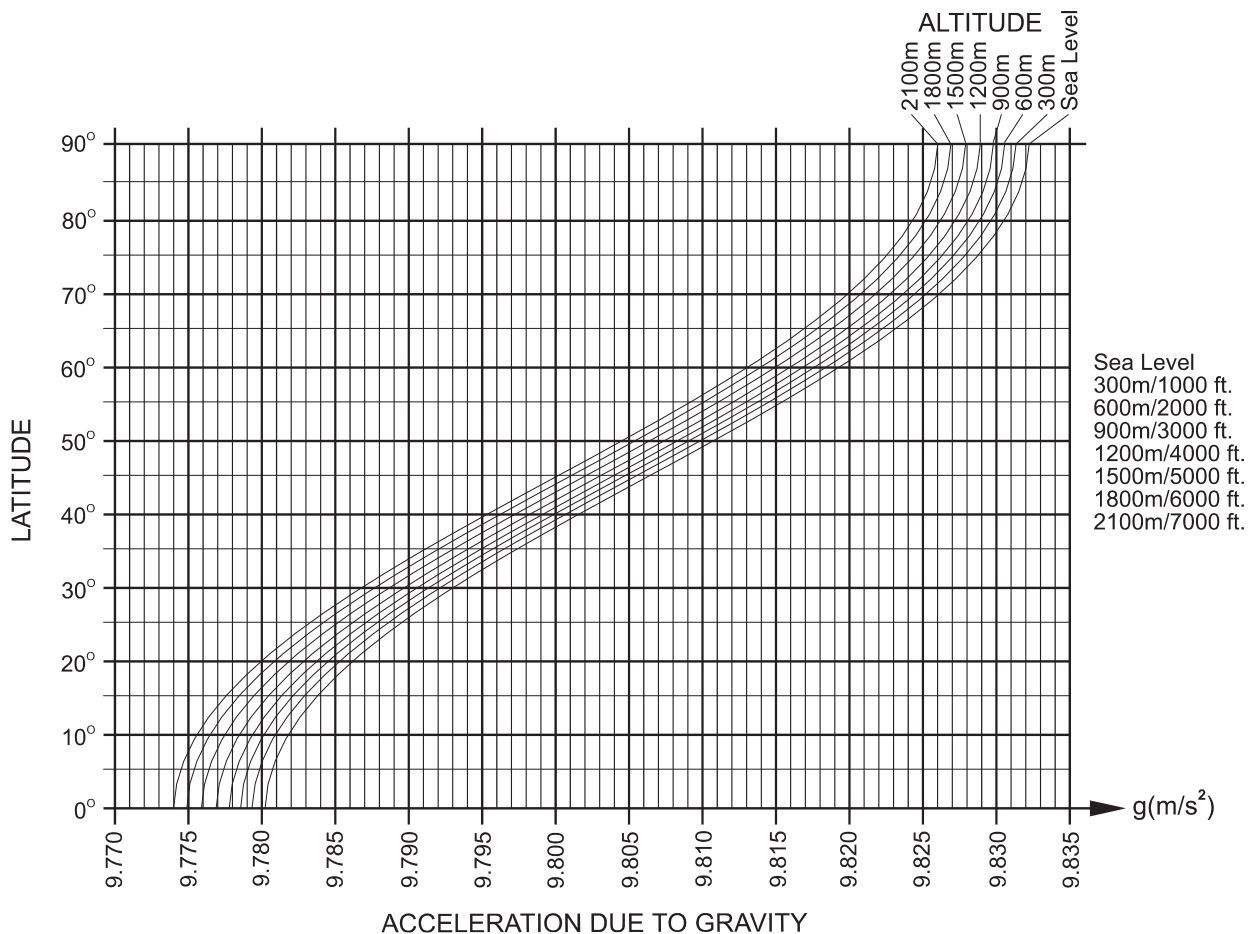



A&D Company, Limited

3-23-14 Higashi-Ikebukuro, Toshima-ku, Tokyo 170-0013, JAPAN
Telephone: [81] (3) 5391-6132 Fax: [81] (3) 5391-1566

A&D ENGINEERING, INC.

1756 Automation Parkway, San Jose, California 95131, U.S.A.
Telephone: [1] (408) 263-5333 Fax: [1] (408)263-0119

A&D INSTRUMENTS LIMITED

Unit 24/26 Blacklands Way, Abingdon Business Park, Abingdon, Oxfordshire OX14 1DY United Kingdom
Telephone: [44] (1235) 550420 Fax: [44] (1235) 550485

A&D AUSTRALASIA PTY LTD

32 Dew Street, Thebarton, South Australia 5031, AUSTRALIA
Telephone: [61] (8) 8301-8100 Fax: [61] (8) 8352-7409

A&D KOREA Limited

한국에이.엔.디(주)
서울특별시 영등포구 국제금융로6길33 (여의도동) 맨하탄빌딩 817 우편 번호 07331
(817, Manhattan Bldg., 33. Gukjegeumyung-ro 6-gil, Yeongdeungpo-gu, Seoul, 07331 Korea)
전화: [82] (2) 780-4101 팩스: [82] (2) 782-4264

ООО A&D RUS

ООО "ЭЙ энд ДИ РУС"
121357, Российская Федерация, г.Москва, ул. Верейская, дом 17
(Business-Center "Vereyskaya Plaza-2" 121357, Russian Federation, Moscow, Vereyskaya Street 17)
тел.: [7] (495) 937-33-44 факс: [7] (495) 937-55-66

A&D INSTRUMENTS INDIA PRIVATE LIMITED

ऐ&डी इन्स्ट्रूमेन्ट्स इण्डिया प्रा० लिमिटेड
509, उद्योग विहार, फेस -5, गुडगांव - 122016, हरियाणा, भारत
(509, Udyog Vihar, Phase-V, Gurgaon - 122 016, Haryana, India)
फोन : 91-124-4715555 फैक्स : 91-124-4715599