

AD-8923-CC



Remote Controller (CC-Link)

INSTRUCTION MANUAL



Warning Definitions

To prevent accidents due to inappropriate handling, this manual contains the following warning signs and marks. The meaning of these warning signs and marks are as follows.

 WARNING	If this notation is ignored and mishandled, it indicates that a person may be killed or seriously injured.
 CAUTION	If this notation is ignored and mishandled, it indicates that a situation where a person is injured or property damage is expected to occur.

© 2010 A&D Company Ltd. All rights reserved.

No part of this publication may be reproduced, transmitted, transcribed, or translated into any language in any form by any means without the written permission of A&D Company Ltd.

The contents of this manual and the specifications of the instrument covered by this manual are subject to change for improvement without notice.

CONTENTS

1. INTRODUCTION	4
1.1. Features	4
1.2. Safety precautions.....	5
1.3. Applicable instruments	6
1.4. Compliance	7
2. DESCRIPTION OF EACH PART	8
2.1. Display.....	9
2.2. Key operation	9
3. CONNECTION TO WEIGHING INSTRUMENT AND CC-LINK	10
3.1. Connection Examples for weighing instruments and CC-Link	10
3.2. Power supply connection.....	13
3.3. Setting the weighing instrument and AD-8923-CC	14
3.4. Sensitivity adjustment (AD-4212C, AD-4212F).....	15
4. INITIALIZING THE AD-8923-CC	17
5. FUNCTION SETTING	18
5.1. Display and keys	19
5.2. Function table	19
6. RS-232C CONNECTOR	20
7. CC-LINK CONNECTOR	21
7.1. CC-Link interface specifications	21
7.2. Timing chart.....	26
7.3. Fixing the decimal point position.....	28
7.4. Sensitivity adjustment by CC-Link register (AD-4212C, AD-4212F)	29
8. TROUBLESHOOTING	30
9. SPECIFICATIONS	31
10. EXTERNAL DIMENSIONS	32
11. MOUNTING TO PANEL	33

1. INTRODUCTION

This manual describes how the AD-8923-CC remote controller works and how to get the most out of it in terms of performance.

Read this manual thoroughly before using the AD-8923-CC and keep it at hand for future reference.

1.1. Features

Connecting the AD-8923-CC remote controller to a weighing instrument will enable transmission of RS-232C weighing data from the weighing instrument to a PLC using CC-Link (*1).

- Displays the weighing data transmitted from the weighing instrument.
- Key operations remotely control the weighing instrument (*2).
- Using the CC-Link (*3) interface, the AD-8923-CC can receive the weighing data or perform re-zeroing of the weighing instrument.

Note:

*1 The AD-8923-CC CC-Link is a remote device station of CC-Link ver. 1.10.

*2 Entering the function setting mode of the weighing instrument is not available. Available operations depend on the weighing instrument used. Refer to Table 2 in “[1.3 Applicable instruments](#)”.

*3 CC-Link is a high-speed field network able to simultaneously handle both control and information data. With a high communication speed of 10 Mbps, CC-Link can achieve a maximum transmission distance of 100 meters and connect to 64 stations.

When a CC-Link network is configured using the AD-8923-CC, the maximum number of stations (or units) will be 42.

1.2. Safety precautions

If this instrument is used in a manner other than that specified by A&D, the protection provided by the instrument may be impaired. Please read the following precautions carefully before using this instrument.

WARNING

- Install a safety circuit external to this instrument so that the entire system operates safely even in the event of an abnormality in the external power supply or a malfunction of this instrument.

- Use this instrument indoors. Never use it in the following environments.
 - Environments with corrosive or flammable gases.
 - Environment where this instrument may come in contact with oil, chemicals, or water.

- Before carrying out any wiring work, be sure to shut off all phases of the external power supply used by the system.

CAUTION

- Do not disassemble this instrument.

- If the front panel becomes dirty, wipe it with a soft cloth lightly dampened with water. Do not use organic solvents such as benzene, thinner, or alcohol as they may cause deformation or discoloration.

[Power supply connection]

- Do not use the instrument at a voltage exceeding the rated voltage range (24 VDC \pm 10%) of the external power supply (24V) input terminal.
 - Doing so may cause malfunction or overheating.
 - This instrument may not operate properly.

- Separate the external power input terminal of this instrument from the power supply of other instruments.

- Ground the ground terminal of this instrument.
 - This avoids electric shock and improves the safety of the system.
 - This may improve resistance to noise.

- When using an AC adapter, use the designated dedicated AC adapter.
 - If you use the wrong AC adapter, it may not work properly.
 - Do not connect the provided AC adapter to other devices.

- The external connection port should be connected to a circuit that is isolated from hazardous voltages by using double/reinforced insulation.

1.3. Applicable instruments

The AD-8923-CC functions in two ways as follows, depending on the weighing instrument used:

- A remote controller that displays the weighing data and remotely controls the weighing instrument.
- A remote display that displays the weighing data.

Available key operations depend on the weighing instrument used. (Refer to “Table 2”)

For weighing instruments not listed in this table, please refer to the A&D website.

Table 1 Applicable weighing instruments and what is required

Weighing instrument	What is required to connect to weighing instrument	
	Option for the instrument	Communication cable (Length: 2 m)
AD-4212C, AD-4212D	None (D-sub 9 pin)	None (Use the cable provided for AD-4212C, AD-4212D) ^{*1*3}
AD-4212F	None (D-sub 9 pin)	AX-KO3590-XXX ^{*2} or AX-KO7796-XXX ^{*3}
AD-4212A, AD-4212B, GX, GF, GX-K, GF-K, MC, GP, GR	None (D-sub 25 pin)	AX-KO1710-200
GX-A, GF-A, GX-M, GF-M, GX-L, GF-L, FZ, FX, EK-I, EW-i, EK-L, BM, GH, HR-i, HR-AZ, HR-A	None (D-sub 9 pin)	AX-KO2741-180
EJ, HV-C, HV-CP, HW-C, HW-CP	OP-03 (D-sub 9 pin)	AX-KO2741-180
HV-G, HV-WP, HW-G, HW-WP	None (Din 8 pin)	AX-KO1786-200
FG-L, FG-M	OP-23 (Din 8 pin)	AX-KO1786-200
FS-i, SC, SE, SW	OP-03 (Wire)	AX-KO3285-320

^{*1} When connecting to the AD-4212C or AD-4212D, use the cable provided as a standard accessory for the AD-4212C or AD-4212D.

The part number for standard accessory cable for the AD-4212C is AX-KO3590-1000 or AX-KO7796-1000 (10 m).

The part number for standard accessory cable for the AD-4212D is AX-KO3590-200 or AX-KO7796-200 (2 m).

^{*2} For “XXX”, choose from 200 (2 m), 500 (5 m), or 1000 (10 m).

^{*3} If the applicable model is a UL certified product, choose the cable from the option below; AX-KO7796-1000 (10m) or AX-KO7796-200 (2m)

Table 2 Applicable weighing instruments and key operations

Weighing instrument	AD-8923-CC keys					
	ON:OFF	CAL	SAMPLE	PRINT	MODE	RE-ZERO
AD-4212C, AD-4212F	Turns the weighing instrument display on or off. (Note 1)	Performs sensitivity adjustment using the external weight	Switches the readability (Note 2)	Determines operation during various settings	Switches the response characteristic	Sets the display to zero
AD-4212D		Performs sensitivity adjustment using the internal weight (Note 4)				
GX, GX-A, GX-M, GX-L, GX-K, GP, GH, FZ, MC, BM, HR-AZ					-	
GR						
GF, GF-A, GF-M, GF-L, GF-K, AD-4212A, AD-4212B, HR-i, FX, HR-A					-	
EJ, EK-i, EW-i, EK-L, FG-L, FG-M, FS-i, SW, HV-G, HV-WP, HW-G, HW-WP, HV-C, HV-CP, HW-C, HW-CP	(Note 5)					

* "-" in the table indicates that the key operation is not available.

Note 1) Switching the standby or weighing mode is available for the AD-4212C, AD-4212D and AD-4212F.

Note 2) Not available for the counting mode or percent mode.

Note 3) Not available for the AD-4212A and AD-4212B.

Note 4) For weighing instruments other than AD-4212C, AD-4212D and AD-4212F, the AD-8923-CC displays "-----".

Operate on the measuring instrument side.

Note 5) Do not operate by using the key on the AD-8923-CC.

1.4. Compliance

Compliance with FCC Rules

Please note that this equipment generates, uses and can radiate radio frequency energy. This equipment has been tested and has been found to comply with the limits of Class A digital devices pursuant to Part 15 of FCC rules. These rules are designed to provide reasonable protection against interference when equipment is operated in a commercial environment. If this unit is operated in a residential area, it may cause some interference and under these circumstances the user would be required to take, at his own expense, whatever measures are necessary to eliminate the interference.

(FCC = Federal Communications Commission in the U.S.A.)

2. DESCRIPTION OF EACH PART

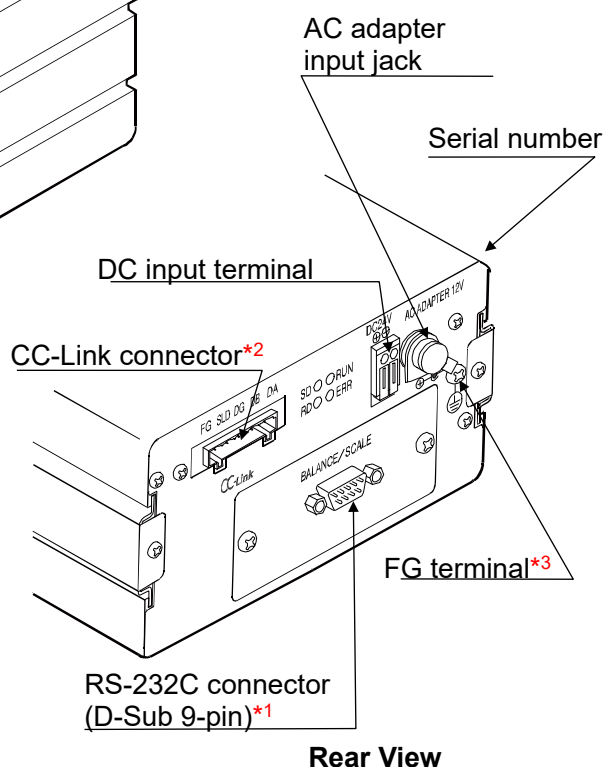
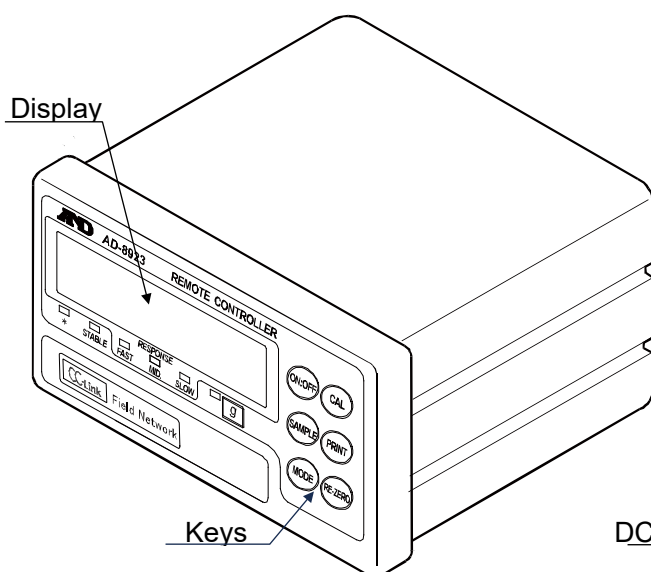

Accessories

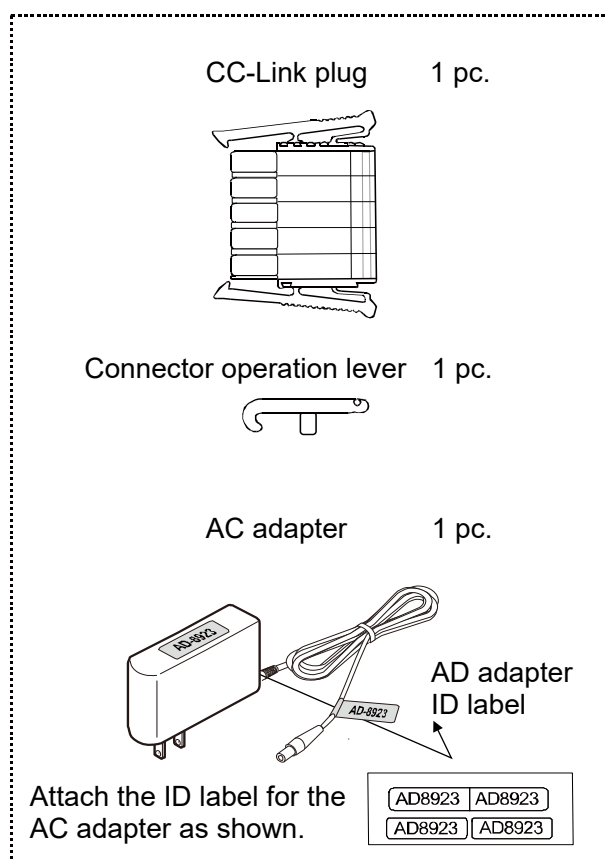

Note:

- Please confirm that the AC adapter type is correct for your local voltage and receptacle type.

*1 RS-232C connector (BALANCE/SCALE): D-sub 9 pin [Male]

This is used for the connection of the weighing instrument. The cable to be connected depends on the instrument. Refer to the instruction manual for the weighing instrument.

*2 CC-Link: Connector 5-pin [Male]

Use the AD-8923-CC with each other or with a PLC or other CC-Link connectivity device. Refer to [7. CC-LINK CONNECTOR](#) for more detail.

*3 When the AD-8923-CC is to be built into a weighing system, be sure to ground the FG terminal.

2.1. Display

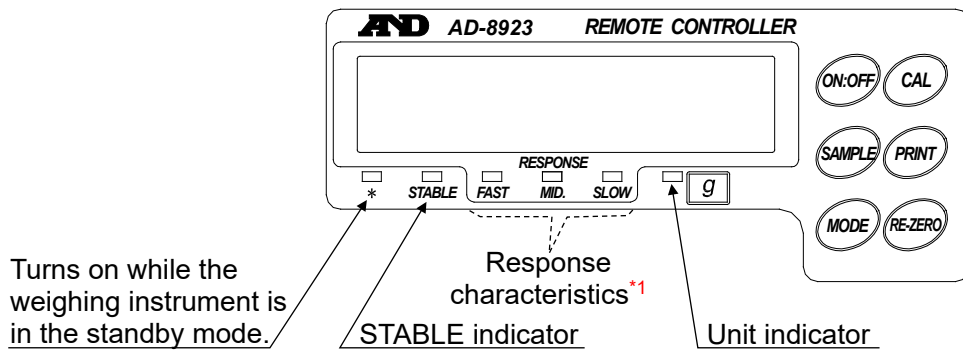

- Displays the weighing data received. When the unit is “g” (gram), the unit indicator turns on. If the balance outputs RS-232C weighing data that exceeds six digits, the AD-8923-CC does not display the high-end digits. (2 highest digits for an 8-digit display)
- Weight value of the CC-link is output even if it exceeds six digits.
- When the weight value is stable (the header of the weighing data received is “ST”), the STABLE indicator turns on.
- If the AD-8923-CC does not receive the weighing data for two seconds or more, ----- is displayed (Bar display).

*1 When the AD-4212C, AD-4212D and AD-4212F is connected, displays the response characteristics. The other models are not displayed.

2.2. Key operation

- It is a key switch for operating the weighing instrument. The operation differs depending on the weighing instrument. Refer to "Table 2" in "**1.3 Applicable instruments**" for more details.
- To enter the function setting of the AD-8923-CC, press the CAL key while holding down the ON:OFF key.
For details, refer to "**5 FUNCTION SETTING**".

3. CONNECTION TO WEIGHING INSTRUMENT AND CC-LINK

3.1. Connection Examples for weighing instruments and CC-Link

Connect the cables using the connectors located on the rear of the AD-8923-CC.

Connection example to the AD-4212C and a PLC

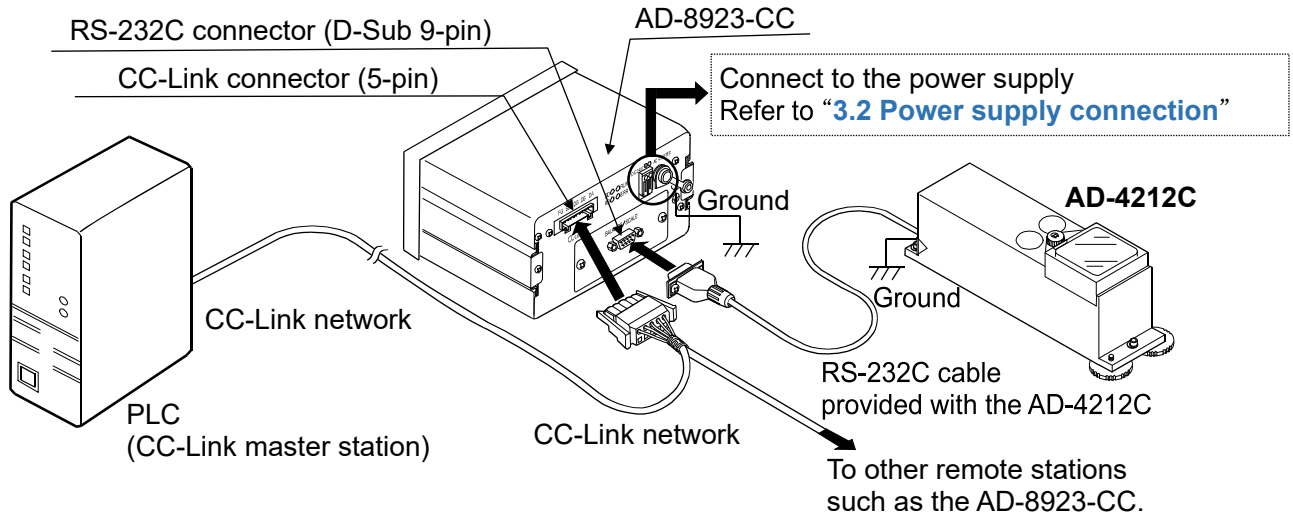

Note:

- Be sure to ground the AD-4212C and the AD-8923-CC.

Connection example for the CC-Link network (weighing instruments No.1 through No.4)

Connect a terminating resistor only to the stations at each end of the network.

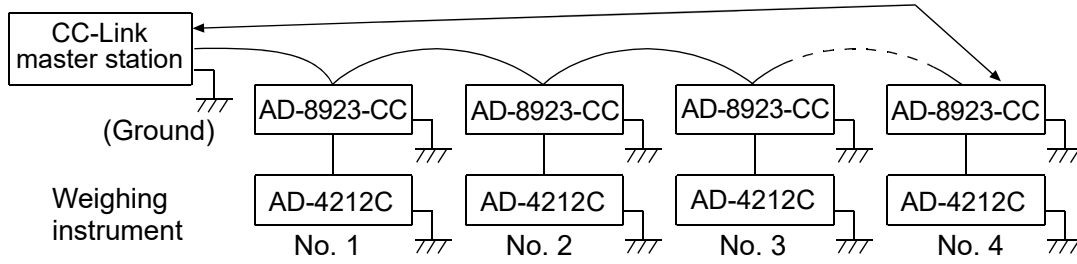

- The value of the terminating resistor varies depending on the CC-Link cable used.
- Use the same resistance value at each end of the network.

Cable	FANC-110SBH
Terminating resistor	110Ω 1/2 W

Terminating resistors are not provided.

- When connecting the AD-8923-CC to the CC-Link network using the connector provided (721-105/037-000 equivalent), use the ferrule listed below (sold separately).
(Example: When using the FANC-110SBH cable)

Insert the cable into the ferrule and crimp it using the Variocrimp4 206-204 crimping jig, and insert it into the connector.

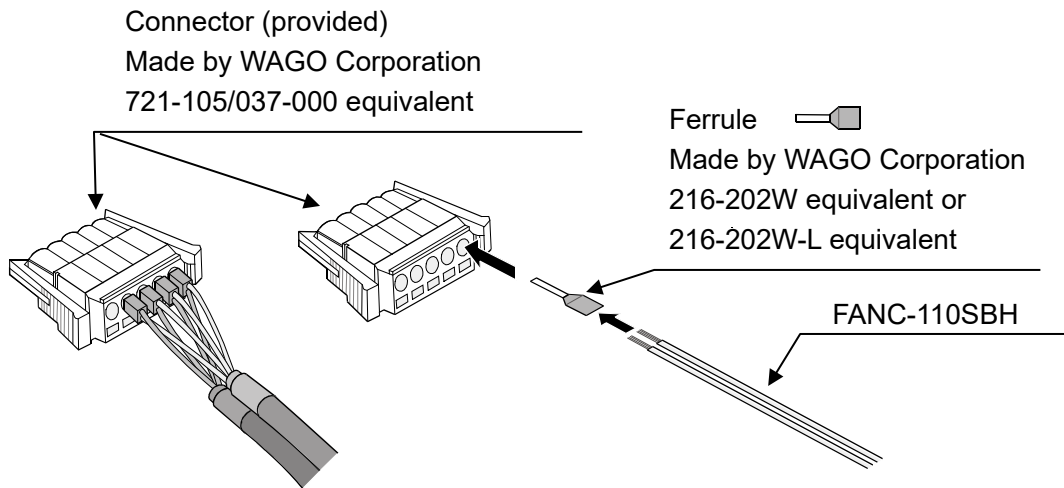

- A dual cable connection is also available (not provided).
(Example: when using the FANC-110SBH cable)

Insert the cable into the ferrule and crimp it using the Variocrimp4 206-204 crimping jig, and insert it into the connector.

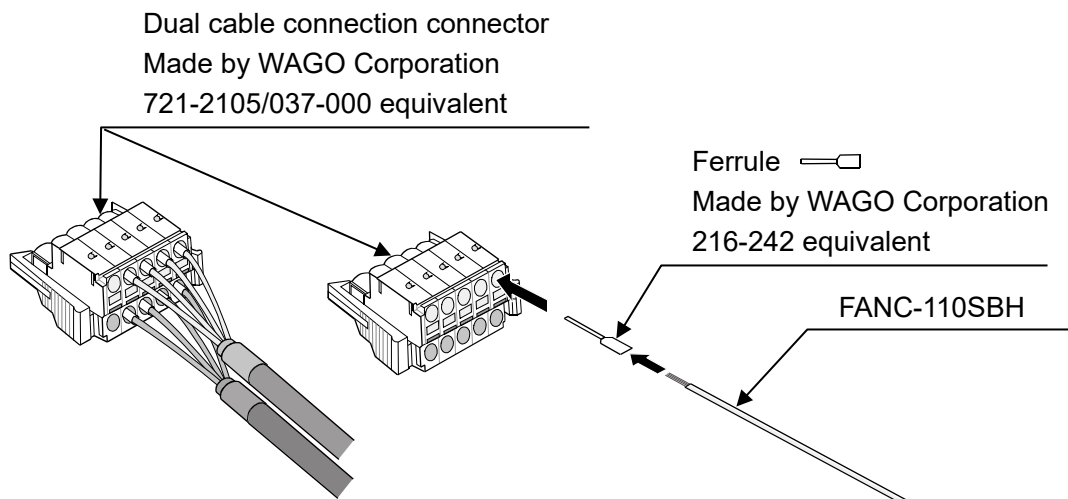

3.2. Power supply connection

Either an external 24 VDC power supply or an AC adapter can be used.

When connected to the following instruments, power can be supplied to both that weighing instrument and the AD-8923-CC by plugging the AC adapter into either one of them.

(Both instruments can have their AC adapter connected at the same time.)

Applicable Instruments: AD-4212C, AD-4212D, AD-4212F, FZ, FX, GX-A, GF-A, GX-M, GF-M, GX-L, GF-L, HR-AZ, HR-A

Refer to the A&D HP for the latest applicable models.

⚠ CAUTION

For the power supply connection, refer to “[1.2 Safety precautions](#)”.

When the external 24 VDC power supply is used

Connect an external 24 VDC power supply to the DC input terminal located on the rear of the AD-8923-CC.

Cable connection

⚠ CAUTION

Before inserting the power line, make sure that the power to the AD-8923-CC is turned off.

1. Inserting the power line
Press down the release button on the DC input terminal using a screwdriver and insert the power line.
The recommended stripping length for the power line is 10 mm.

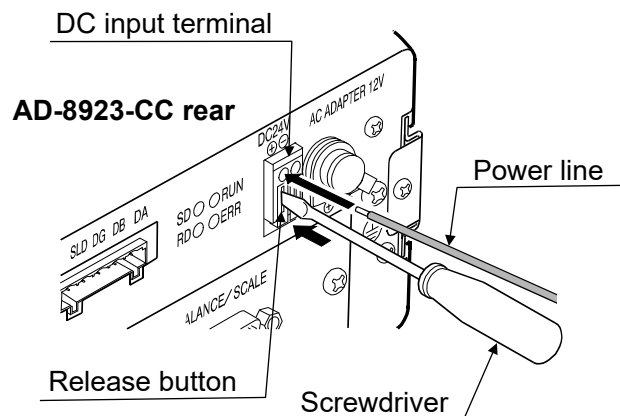

Applicable wire range

- Single wire: $\phi 1.0$ mm (AWG 26) to $\phi 1.2$ mm (AWG 16)
- Twisted wire: 0.3 mm² (AWG 22) to 0.75 mm² (AWG 20)
Individual wire diameter $\phi 0.18$ mm or greater

2. Securing or removing the power line
To secure the power line, return the release button to the initial position using the screwdriver. The power line will be locked. To remove the power line, press the release button again using the screwdriver, unlocking the power line.

When the AC adapter is used

Insert the AC adapter plug into the AC adapter input jack located on the rear of the AD-8923-CC and insert the AC adapter into an electrical outlet.

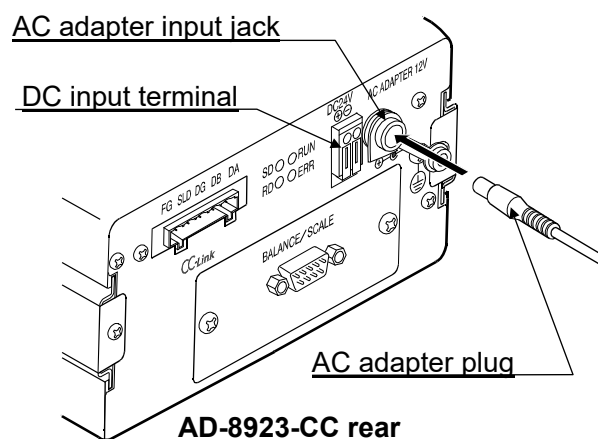

3.3. Setting the weighing instrument and AD-8923-CC

Set the following items so that the weighing instrument and the AD-8923-CC have the same value for each item.

Item	Weighing instrument	AD-8923-CC
Baud rate	600, 1200, 2400*, 4800, 9600, 19200 bps	
Data bits, parity	7 bits EVEN*	
Stop bits	1 bit*	
Terminator	<CR><LF>*	
Data format	A&D standard format	—
Communication control	No RTS/CTS control	—
Data output mode	Stream mode	—

* Factory setting for the AD-8923-CC. The factory setting for the weighing instruments is the same unless otherwise specified.

3.4. Sensitivity adjustment (AD-4212C, AD-4212F)

The following is the sensitivity adjustment procedure when the AD-4212C and the AD-4212F are connected. (An external weight is used.)

Caution

- Do not allow vibration, drafts or temperature change to affect the AD-4212C during sensitivity adjustment.

Caution on using an external weight

- The accuracy of the weight can influence the accuracy of weighing.
Select an appropriate weight as listed below.
- A weight of 200 g is provided with the AD-4212C as a standard accessory.

Weighing instrument	Usable weight
AD-4212C-300 AD-4212C-301	50 g, 100 g, 200 g , 300 g
AD-4212C-600	50 g, 100 g, 200 g , 300 g, 400 g, 500 g, 600 g
AD-4212C-3000 AD-4212C-3100	50 g, 100 g, 200 g , 300 g, 500 g, 1000 g, 2000 g, 3000 g
AD-4212C-6000	200 g , 500 g, 1000 g, 2000 g, 3000 g, 4000 g, 5000 g, 6000 g
AD-4212F-6203D	50 g, 100g, 200 g, 300 g, 500 g, 1000 g, 2000 g , 3000 g, 4000 g, 5000 g, 6000 g
AD-4212F-10202	500 g, 1000 g, 2000 g, 3000 g, 4000 g, 5000 g , 6000 g, 7000 g, 8000 g, 9000 g, 10000 g
AD-4212F-22001	1000 g, 2000 g, 5000 g, 10000 g , 20000 g

The weight in bold type: Factory setting

Display



This indicator means “the AD-4212C is measuring sensitivity adjustment data”. Do not allow vibration, drafts or other external disturbances to affect AD-4212C while this indicator is displayed.

Sensitivity adjustment procedure

Performs sensitivity adjustment with the AD-4212C using an external weight.

Operation

1. Warm up the AD-4212C for 30 minutes or more with nothing on the pan.

2. Press the **CAL** key. **CAL 0** is displayed.

- If you want to cancel sensitivity adjustment, press the **CAL** key. The display will return to the weighing mode.
- If you want to change the weight value, press the **SAMPLE** key. Press the **RE-ZERO** key to select the weight value, and press the **PRINT** key to store it. **CAL 0** is displayed.

3. Confirm that there is nothing on the pan and press the **PRINT** key.

The AD-4212C measures the zero point. Do not allow vibration or drafts to affect the AD-4212C. The weight value is displayed.

4. Place a weight, of the weight value displayed, on the pan and press the **PRINT** key. The AD-4212C measures the weight. Do not allow vibration or drafts to affect the AD-4212C.

5. **End** is displayed. Remove the weight from the pan.

6. The display will automatically return to the weighing mode.

7. Place the weight on the pan and confirm that adjustment was performed correctly. If not, check the ambient conditions such as drafts or vibration, and repeat steps 2 through 7.

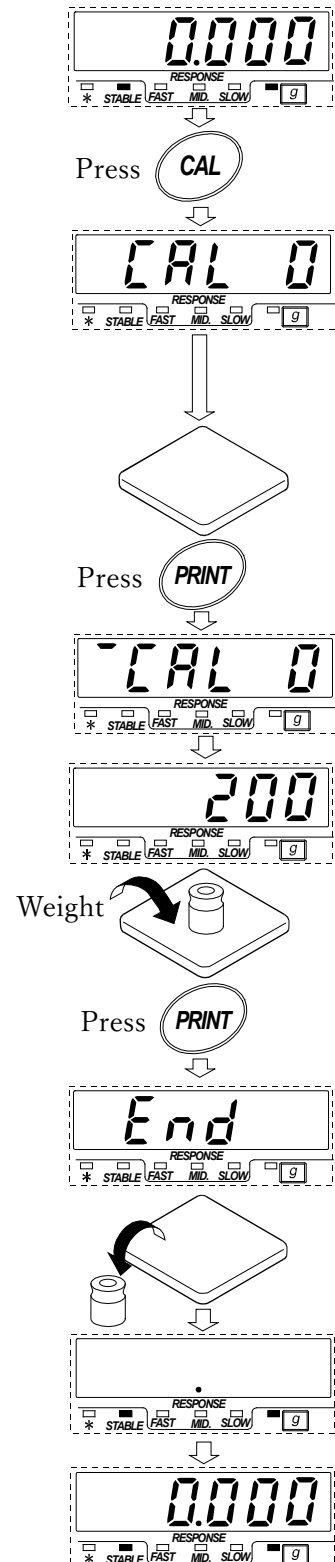

* It is also possible to carry out sensitivity adjustment described above using the register of the CC-Link. For details, refer to [“7.4 Sensitivity adjustment by CC-Link register \(AD-4212C, AD-4212F\)”](#)

4. INITIALIZING THE AD-8923-CC

Initialization restores the function settings of the AD-8923-CC to factory settings.

Operation

1. Turn the power on. or weighing mode display appears.
2. While holding down the key, press the key. is displayed.
3. Press the key.
To cancel this operation, press the key
4. Press the key to select "".
5. Press the key to perform initialization.
After initialization, or weighing mode display appears.

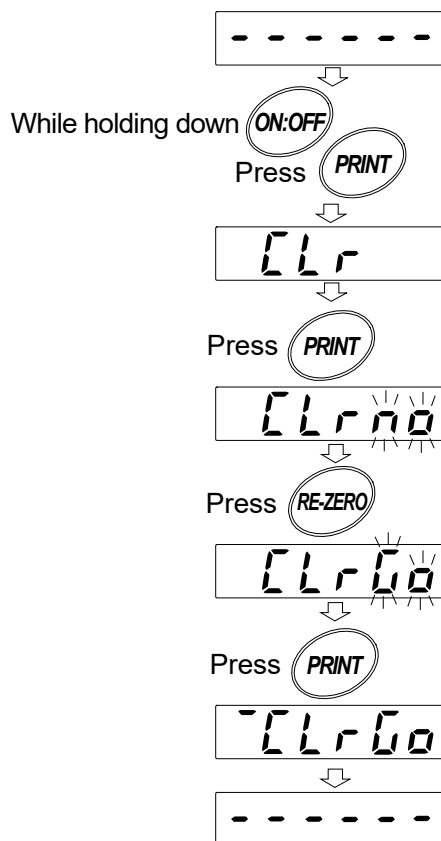

5. FUNCTION SETTING

Function setting specifies the AD-8923-CC performance. The parameters are stored in non-volatile memory, and are maintained even if the power line or AC adapter is removed.

The function setting menu consists of two layers. The first layer is the “Class” and the second layer is the “Item”. Each item stores a parameter.

Press the **SAMPLE** key to select an item and press the **RE-ZERO** key to change the parameter. Then, press the **PRINT** key to store the new parameter.

Example:



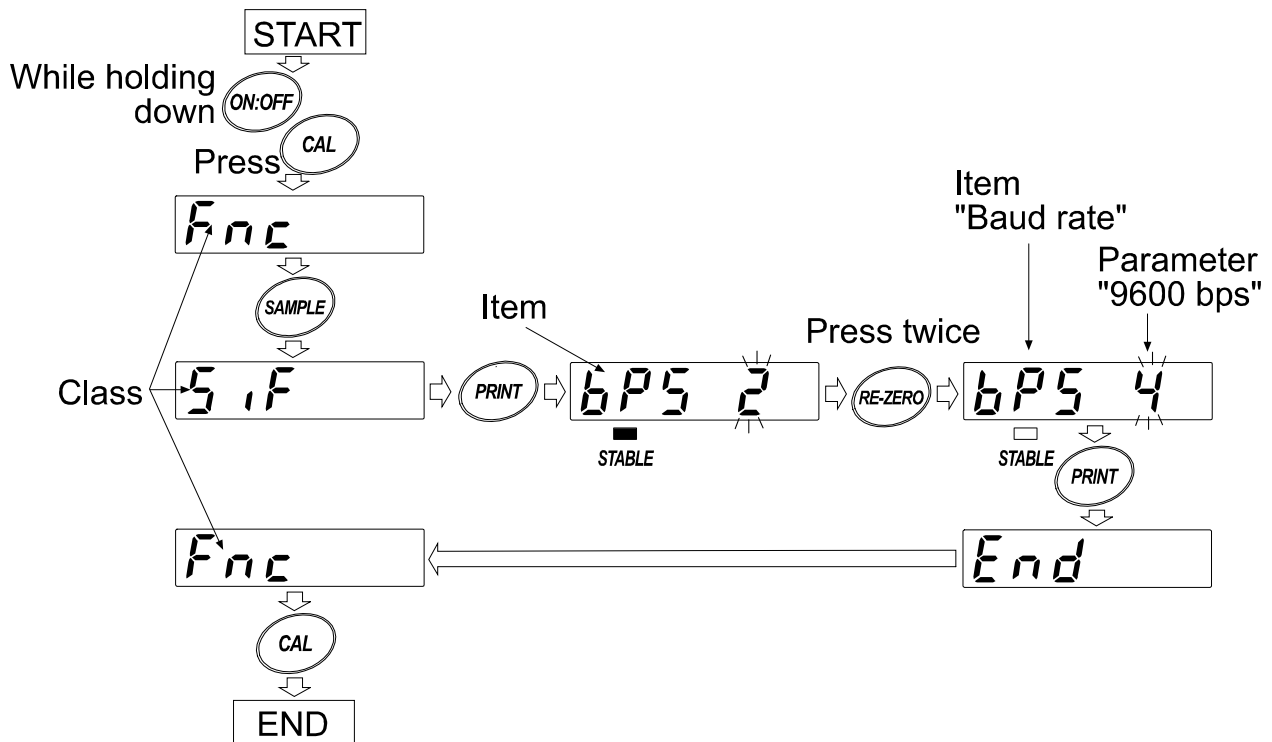

Setting “Baud rate” to “9600 bps”.

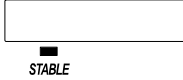

Note:

- The AD-8923-CC may not function properly, depending on the settings and operating environment. Check the settings and change them as necessary.

5.1. Display and keys

	The STABLE indicator turns on to indicate that the parameter displayed is in effect.
	Selects a class or item.
	Changes the parameter.
	When a class is displayed, moves to an item in the class. When an item is displayed, stores the new parameter and displays the next class.
	When an item is displayed, cancels the new parameter and displays the next class. When a class is displayed, exits the function setting mode and returns to the weighing mode.

5.2. Function table

Class	Item and Parameter	Description		
<i>Fnc</i> Environment Display	<i>dPP</i> Decimal point position	▪ -	Not fixed	Displays the decimal point position of the weighing data received.
		0 to 5	Fixed	Fixes the decimal point at the set digit. Even if the minimum display is switched using the SAMPLE key, the decimal point position does not change. For details, refer to “ 7.3. Fixing the decimal point position ”
	<i>SAPL</i> Sample key function	0	Disabled	Disables the SAMPLE key function.
		▪ 1	Enabled	Enables the SAMPLE key function.
<i>SIF</i> Serial interface	<i>bPS</i> Baud rate	0	600 bps	Set the same value as that of the weighing instrument to be connected.
		1	1200 bps	
		▪ 2	2400 bps	
		3	4800 bps	
		4	9600 bps	
		5	19200 bps	
<i>[[[</i> CC-Link interface	<i>nSt</i> Number of station	▪ 1 to 64	Number of station	Set the same value as that of the CC-Link master station to be connected.
		0	156 Kbps	
	1	625 Kbps		
	2	2.5 Mbps		
	3	5 Mbps		
<i>[-bP</i> CC-Link baud rate	▪ 4	10 Mbps		

▪ Factory setting

6. RS-232C CONNECTOR

Connector	D-Sub9 pin (Male)
Transmission system	EIA RS-232C
Transmission form	Asynchronous, Bi-directional
Data format	Baud rate 600, 1200, 2400, 4800, 9600, 19200 bps
	Data bits 7 or 8 bits
	Parity EVEN, ODD (Data bits 7 bits) NONE (Data bits 8 bits)
	Stop bits 1 bit or 2 bits
	Code ASCII
	Terminator <CR> or <CR><LF>

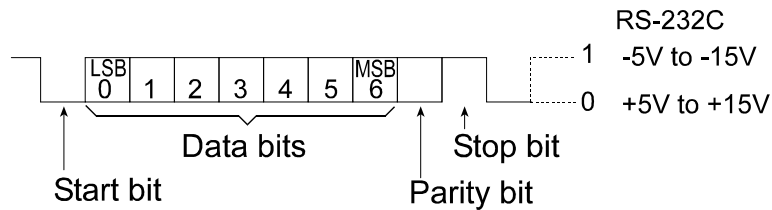

Circuit

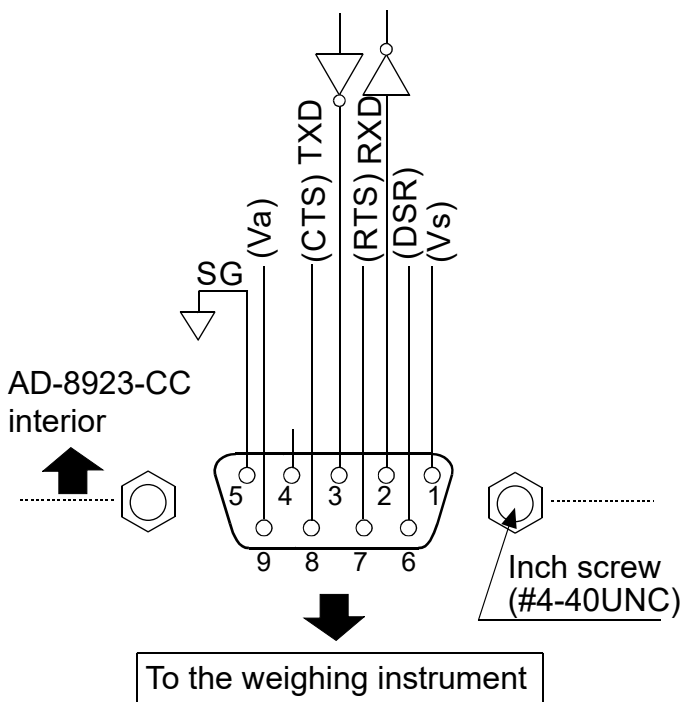

Connection to the weighing instrument
D-Sub 9-pin male

Pin No.	Signal name	Direction	Description
1	(Vs)	-	Used internally
2	RXD	Input	Receive data
3	TXD	Output	Transmit data
4	-	-	N.C.
5	SG	-	Signal ground
6	(DSR)	Input	Used internally
7	(RTS)	Output	Used internally
8	(CTS)	Input	Used internally
9	(Va)*1	-	Used internally

(The AD-8923-CC is a DTE instrument. Connect to a DCE device such as the weighing instruments using a straight through cable.)

When the user prepares a cable, do not connect to the pins that are used internally.

*1 Used when connecting to some A&D measuring instruments. Using the wrong cable may damage the equipment. Be sure to check the applicable cables. For cables, refer to "1.3 Applicable instruments".

When connecting to a PC, PLC, or other product other than the applicable model listed in "3.2 Power supply connection" do not connect the 9-pin.

7. CC-LINK CONNECTOR

The AD-8923-CC CC-Link is a remote device station of CC-Link ver.1.10. When a CC-Link is used, the AD-8923-CC can be controlled by the PLC remote I/O or remote registers. So, the program can be simple. And connection to a PLC is simple, thus, a weighing system can be built easily. The setting values of CC-Link are changed in the function setting [LL].

7.1. CC-Link interface specifications

Number of stations	1 to 64
Baud rate	156 kbps, 625 kbps, 2.5 Mbps, 5 Mbps, 10 Mbps

Communications connector

The connector used can be attached or removed while the power is ON.

The function of each signal line is as follows.

DA	Signal DA
DB	Signal DB
DG	Signal ground
SLD	Shield
FG	Frame ground

Status LEDs

LED	ON	OFF	Blinking
RUN	Normal	<ul style="list-style-type: none"> Resetting No signal 	-
SD	Transmitting	-	-
RD	Receiving	-	-
ERR	<ul style="list-style-type: none"> Setting error CRC error Station trouble 	Normal	When the setting values are changed

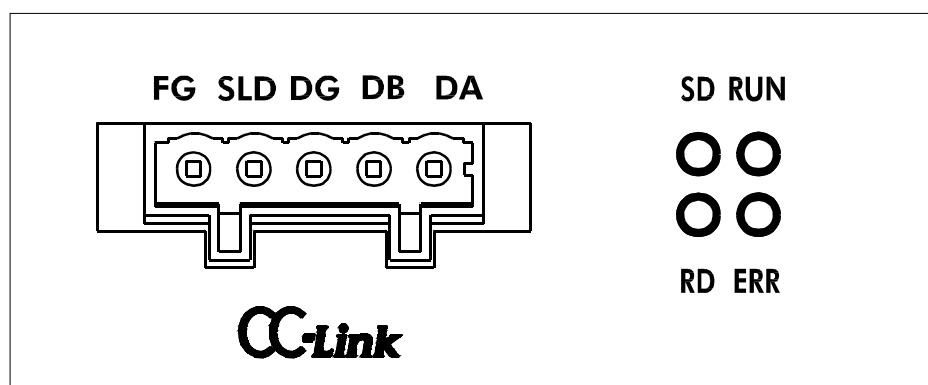

CC-Link connector and LEDs

Memory map

Remote register (Number of occupied stations: 1)

Blank "Name" column: internally reserved (not used).

AD-8923-CC → Master station			Master station → AD-8923-CC		
Remote register	Buffer memory	Name	Remote register	Buffer memory	Name
RWr0000	2E0	Weight value*	RWw0000	1E0	
RWr0001	2E1		RWw0001	1E1	
RWr0002	2E2		RWw0002	1E2	
RWr0003	2E3		RWw0003	1E3	

* Contains data entered in A&D standard format with headers ST, US, OL.

Remote I/O (Number of occupied stations: 1)

Blank "Name" column: internally reserved (not used).

AD-8923-CC → Master station			Master station → AD-8923-CC		
Remote input	Buffer memory	Name	Remote output	Buffer memory	Name
RX0000	0E0	State flag of sensitivity adjustment ^{*1}	RX0000	160	Re-zero
RX0001			RX0001		
RX0002			RX0002		Tare (Re-zero)
RX0003		State flag of sensitivity adjustment progress ^{*1}	RX0003		Sensitivity adjustment ^{*1}
RX0004			RX0004		Operation decision at sensitivity adjustment ^{*1}
RX0005			RX0005		
RX0006		CPU operation	RX0006		Changing of weighing speed ^{*1}
RX0007		Stable/Unstable	RX0007		
RX0008		Decimal point 2 ⁰	RX0008		
RX0009		Decimal point 2 ¹	RX0009		
RX000A		Decimal point 2 ²	RX000A		
RX000B		State flag of response characteristic ^{*1}	RX000B		
RX000C			RX000C		
RX000D			RX000D		
RX000E			RX000E		
RX000F		Weighing error flag ^{*2}	RX000F		
RX0010	0E1		RX0010		
RX0011			RX0011		
RX0012			RX0012		
RX0013			RX0013		
RX0014			RX0014		
RX0015			RX0015		
RX0016			RX0016		
RX0017			RX0017		
RX0018		Request flag of initialization	RX0018	161	Reply flag of initialization
RX0019		Reply flag of initial data setting	RX0019		Request flag of initial data setting
RX001A			RX001A		
RX001B		Remote READY flag	RX001B		
RX001C			RX001C		
RX001D			RX001D		
RX001E		RX001E			
RX001F		RX001F			

^{*1} Only be used when connected to the AD-4212C, the AD-4212D and the AD-4212F.

^{*2} The flag turns on if weighing data is interrupted for approx. 2 seconds. If connected to the AD-4212C, the AD-4212D and the AD-4212F, the flag also turns on during re-zeroing and sensitivity adjustment.

Numeric values of the remote register

All the values are hexadecimal. Negative values are expressed by the two's complement.

Decimal	Hexadecimal (32 bits)
-10	FFFFFFF6
-1	FFFFFFF
0	00000000
1	00000001
10	0000000A

Weight value examples

1.000 will be 1000, thus expressed as 0x000003E8. (RWr0001: 0x0000, RWr0000: 0x03E8)

-1.000 will be -1000, thus expressed as 0xFFFFFC18. (RWr0001: 0xFFFF, RWr0000: 0xFC18)

Prohibited writing in the internally reserved areas

- Writing is prohibited in the internally reserved areas.
- Writing in the remote output (RY) and the remote register (RWw) of the internally reserved areas may cause the AD-8923-CC to malfunction.
- Values of the remote input (RX) and the remote register (RWr) of the internally reserved areas are not fixed.

Stable/Unstable

RX0007	
0	Unstable
1	Stable

Decimal point

RX0008 to RX000A, 3-bit binary notation

RX000A	RX0009	RX0008	Decimal point position
0	0	0	No decimal point
0	0	1	First digit
0	1	0	Second digit
0	1	1	Third digit
1	0	0	Fourth digit
1	0	1	Fifth digit

Decimal point position example

When displaying 1.000, express 3 as a decimal point at the third digit, thus 0x011. (RX000A: 0, RX0009: 1, RX0008: 1)

State flag of sensitivity adjustment *

RX0002	RX0001	RX0000	State
0	0	1	Waiting for zero-point input
0	1	0	Waiting for sensitivity adjustment mass value input
0	1	1	Sensitivity adjustment completed
1	0	0	Sensitivity adjustment error

State flag of sensitivity adjustment progress *

RX0003	Data state
0	Data waiting
1	Data acquiring

State flag of response characteristic*

RX000D	RX000C	RX000B	State of response characteristic
0	0	1	FAST
0	1	0	MID
1	0	0	SLOW

Re-zero/Tare

Sets the weighing instrument to zero.

When the remote I/O register turns on (1), re-zeroing is performed.

* Only be used when connected to the AD-4212C, the AD-4212D and the AD-4212F.

7.2. Timing chart

Below examples are when the station number is set to 1.

When connecting to a power supply

When the AD-8923-CC is connected to a power supply and the CC-Link is ready, the request flag of initialization (RX0018) becomes active.

The master station confirms that RX0018 is active, performs initialization and turns the reply flag of initialization (RY0018) ON.

The AD-8923-CC turns the request flag of initialization (RX0018) OFF and turns the remote READY flag (RX001B) ON.

Turn OFF the reply flag of initialization (RY0018) in the master station.

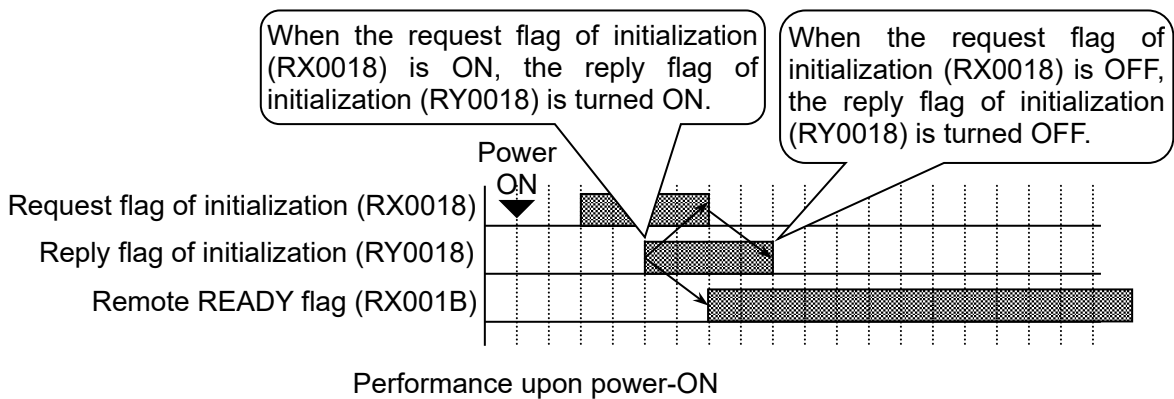

Requesting initialization from the master station

When requesting the initial data setting to the AD-8923-CC from the master station, turn the request flag of initial data setting (RY0019) ON while the remote READY flag (RX001B) is active.

The AD-8923-CC turns the remote READY flag (RX001B) OFF and performs initial data settings. When initial data settings are complete, the reply flag of initial data setting (RX0019) is turned ON.

Turn OFF the request flag of initial data setting (RY0019) in the master station.

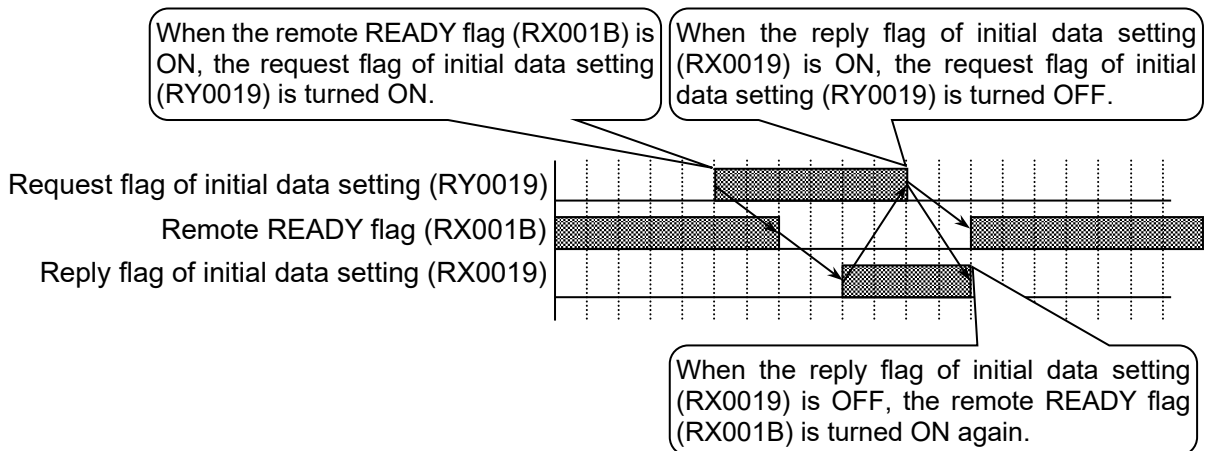

CPU operation

The CPU normal operation (RX0006) is a signal to check that the AD-8923-CC is connected to a power supply and it functions normally. During normal operation, the signal is reversed at an interval of 0.5 to 1 second.

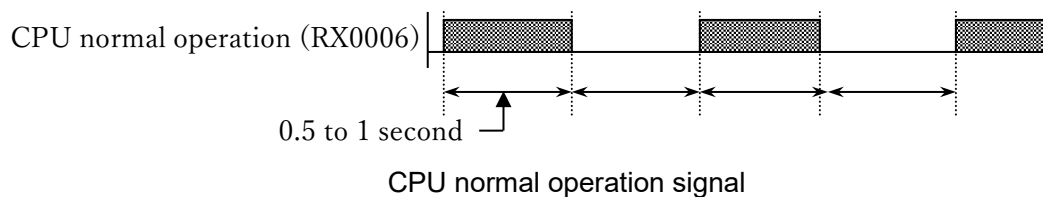

Requesting Re-zeroing from the master station

(When connecting with the AD-4212C, AD-4212D or AD-4212F)

The completion of re-zeroing of the AD-4212C, AD-4212D or AD-4212F can be judged by the measurement abnormality flag (RX000F).

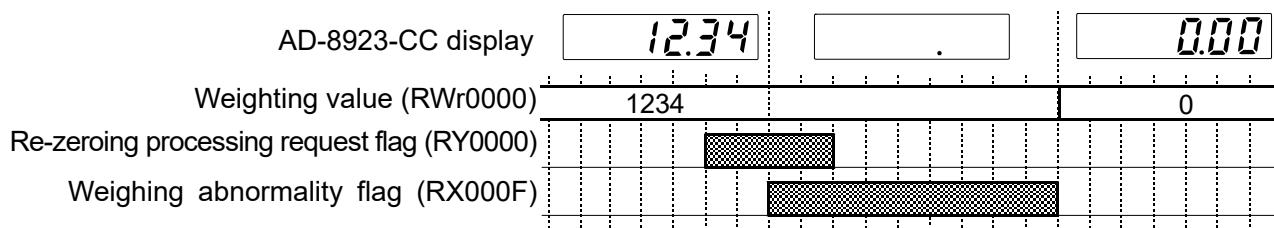

7.3. Fixing the decimal point position

Using the function setting of dPP , the decimal point position of the value displayed on the AD-8923-CC and the decimal point position of the weight value output via CC-Link can be fixed.

In this way, even if the minimum display is switched using the **SAMPLE** key, the digit position for CC-Link output does not change.

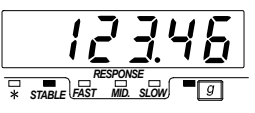
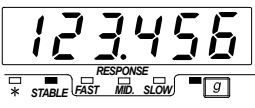

Example 1: Does not fix the decimal point position (dPP -) [Factory setting]

Key	Balance output	AD-8923-CC display	CC-Link output (Weight value) (Decimal point)
	S T , + 0 0 1 2 3 . 4 6 <input type="checkbox"/> <input type="checkbox"/> g C _R L _F		12346 Second digit
	S T , + 0 1 2 3 . 4 5 6 <input type="checkbox"/> <input type="checkbox"/> g C _R L _F		123456 Third digit

Note:

- : Space 20h
- When the minimum display is switched using the **SAMPLE** key, the digits of the weight values output via CC-Link don't align with each other.

Example 2: Fixes the decimal point position to the third digit (dPP 3)

Key	Balance output	AD-8923-CC display	CC-Link output (Weight value) (Decimal point)
	S T , + 0 0 1 2 3 . 4 6 <input type="checkbox"/> <input type="checkbox"/> g C _R L _F		123460 Third digit
	S T , + 0 1 2 3 . 4 5 6 <input type="checkbox"/> <input type="checkbox"/> g C _R L _F		123456 Third digit

Note:

- : Space 20h
- Even if the minimum display is switched using the **SAMPLE** key, the digits of the weight values output via CC-Link align with each other.
- If the balance outputs RS-232C weighing data that exceeds six digits, the AD-8923-CC does not display the high-end digits (it outputs to the CC-Link).

7.4. Sensitivity adjustment by CC-Link register (AD-4212C, AD-4212F)

The following describes the sensitivity adjustment procedure using the register of the CC-Link when connecting the AD-8923-CC to the AD-4212C or AD-4212F. (Using an external weight)

* Only AD-8923-CC software versions P2.05 or later are applicable with this function.

* When performing sensitivity adjustment using the key operation, refer to “3.4 Sensitivity adjustment (AD-4212C, AD-4212F)” for the details.

Caution on sensitivity adjustment

While the sensitivity adjustment is being carried out, take care to use these instruments in an environment where they are not affected by vibration, drafts or temperature change.

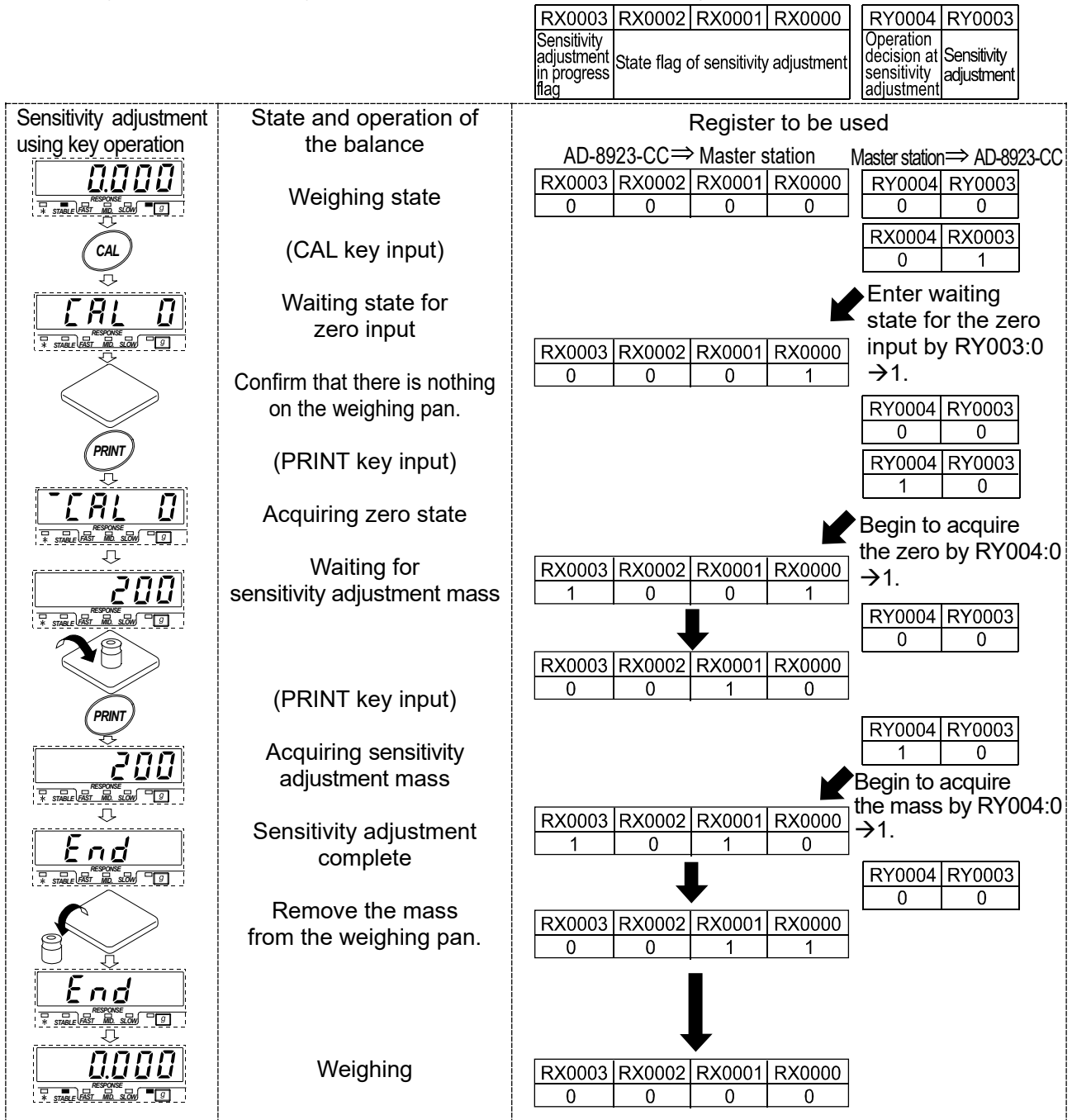

When the sensitivity adjustment cannot be carried out, the state flag of sensitivity adjustment becomes as follows.



Sensitivity adjustment error

RX0003	RX0002	RX0001	RX0000
0	1	0	0

8. TROUBLESHOOTING

Symptom	Description
<div style="border: 1px solid black; padding: 2px; display: inline-block;">Error ID</div> appears.	<ul style="list-style-type: none"> Communication settings of the AD-8923-CC do not match with those of the weighing instrument. Check the settings such as baud rate and parity and correct them as necessary. For details, refer to “3.1. Connection Examples for weighing instruments and CC-Link”.
<div style="border: 1px solid black; padding: 2px; display: inline-block;">-----</div> (Bar display) remains and the weight value is not displayed.	<ul style="list-style-type: none"> Is the data output mode of the weighing instrument set to “stream mode”? In a mode other than “stream mode”, the weight values are displayed only when they are transmitted. Check if the communication settings are correct. Check if the cables are the correct type and are not damaged.
The display flickers.	<ul style="list-style-type: none"> Electrical noise may cause this symptom. Ground the FG terminal located on the rear of the AD-8923-CC.

9. SPECIFICATIONS

Power supply	DC power supply	Input : DC24V ($\pm 10\%$) Current Consumption : approx. 0.7A
	AC adapter	Confirm that the adapter type is correct for the local voltage and power receptacle type. <ul style="list-style-type: none"> • Power consumption : approx. 30 VA (supplied to the AC adapter) • Current Consumption : DC12V, approx. 0.3A (excluding the AC adapter and weighing instrument)
Transmission system		CC-Link (CC-Link Ver. 1.10 Remote Device Station) (1 station possession) RS232C ^{*1}
Operating environment		5 °C to 40 °C (41 °F to 104 °F), 85%RH or less (No condensation)
Altitude		2000m or less
Pollution level		2
External dimensions		144(W)×110(D)×72(H) mm
Net weight		Approx. 620 g

^{*1} Power input/output is possible with some A&D measuring instruments and power supplies.

I/O : 12V ($\pm 10\%$) Current consumption : approx. 0.3A

For models that can input and output power, refer to “[3.2. Power supply connection](#)”

10.EXTERNAL DIMENSIONS

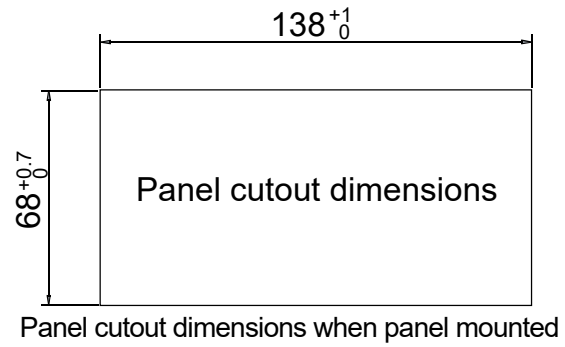
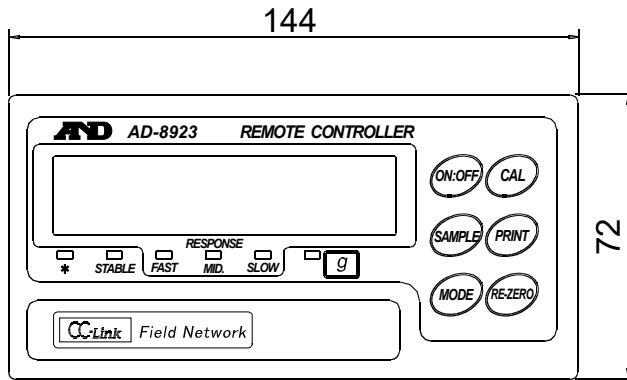
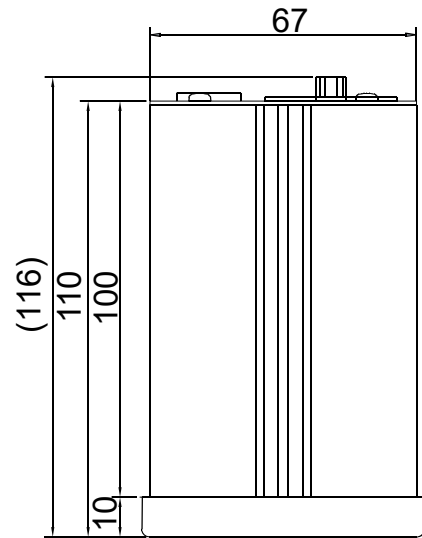
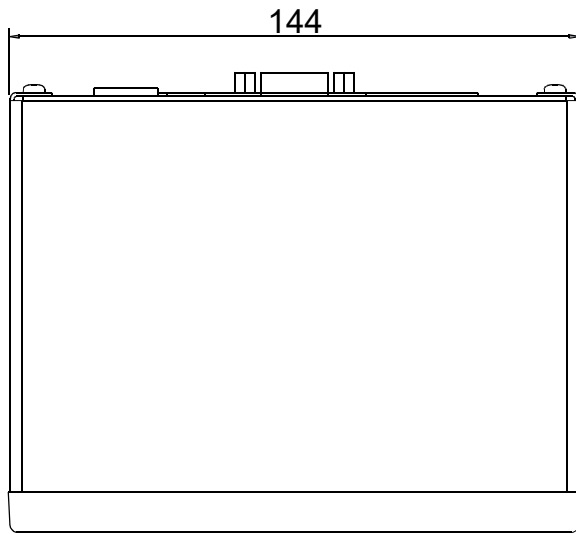

Unit: mm

11.MOUNTING TO PANEL

- (1) Cut the panel to the size of the AD-8923-CC (Refer to the figure on the right).
- (2) Remove the screws (1 piece each) that secure the metal fittings on both sides of the AD-8923-CC from the back of the AD-8923-CC and pull out the metal fittings.
- (3) Insert the AD-8923-CC from the front side of the panel.
- (4) Insert the metal fittings into the grooves on both sides of the AD-8923-CC from the back of the panel and secure them with screws (1 piece each).

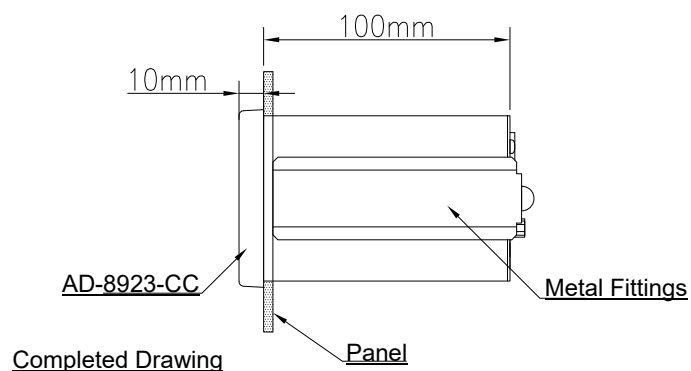
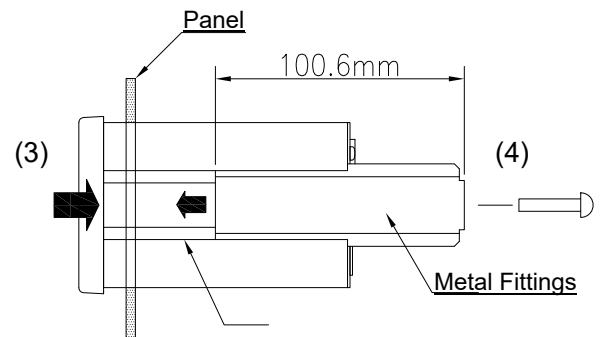
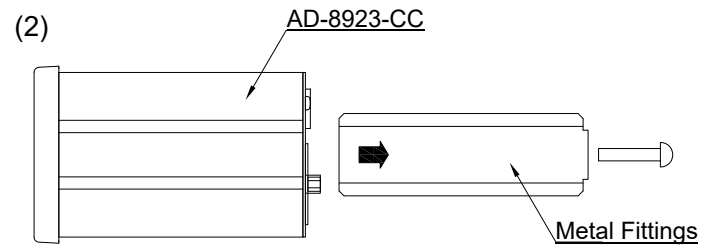
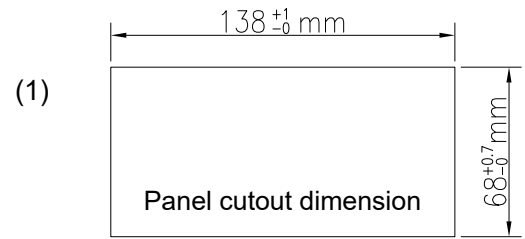

THIS PAGE INTENTIONALLY LEFT BLANK



A&D Company, Limited

3-23-14 Higashi-Ikebukuro, Toshima-ku, Tokyo 170-0013, JAPAN
Telephone: [81] (3) 5391-6132 Fax: [81] (3) 5391-1566

A&D ENGINEERING, INC.

47747 Warm Springs Blvd, Fremont, California 94539, U.S.A.
Tel: [1] (800) 726-3364 Weighing Support:[1] (888) 726-5931 Inspection Support:[1] (855) 332-8815

A&D INSTRUMENTS LIMITED

Unit 24/26 Blacklands Way, Abingdon Business Park, Abingdon, Oxfordshire OX14 1DY United Kingdom
Telephone: [44] (1235) 550420 Fax: [44] (1235) 550485

A&D AUSTRALASIA PTY LTD

32 Dew Street, Thebarton, South Australia 5031, AUSTRALIA
Telephone: [61] (8) 8301-8100 Fax: [61] (8) 8352-7409

A&D KOREA Limited

한국에이.엔.디(주)
서울특별시 영등포구 국제금융로6길33 (여의도동) 맨하탄빌딩 817 우편 번호 07331
(817, Manhattan Bldg., 33. Gukjegeumyung-ro 6-gil, Yeongdeungpo-gu, Seoul, 07331 Korea)
전화: [82] (2) 780-4101 팩스: [82] (2) 782-4264

ООО A&D RUS

ООО "ЭЙ энд ДИ РУС"

Почтовый адрес:121357, Российская Федерация, г.Москва, ул. Вереysкая, дом 17
Юридический адрес: 117545, Российская Федерация, г. Москва, ул. Дорожная, д.3, корп.6, комн. 86
(121357, Russian Federation, Moscow, Vereyskaya Street 17)
тел.: [7] (495) 937-33-44 факс: [7] (495) 937-55-66

A&D Instruments India Private Limited

ऐ&डी इन्स्ट्रुमेन्ट्स इण्डिया प्रा० लिमिटेड

D-48, उद्योग विहार , फेस -5, गुडगांव - 122016, हरियाणा , भारत
(D-48, Udyog Vihar, Phase-V, Gurgaon - 122016, Haryana, India)
फोन : [91] (124) 4715555 फैक्स : [91] (124) 4715599

A&D SCIENTECH TAIWAN LIMITED. A&D台灣分公司 艾安得股份有限公司

台灣台北市中山區南京東路2段206號11樓之2
(11F-2, No.206, Sec.2, Nanjing E.Rd., Zhongshan Dist., Taipei City 10489, Taiwan, R.O.C.)
Tel : [886](02) 2322-4722 Fax : [886](02) 2392-1794

A&D INSTRUMENTS (THAILAND) LIMITED

บริษัท เอ แอนด์ ดี อินสตรูमेंท์ (ไทยแลนด์) จำกัด

168/16 หมู่ที่ 1 ตำบลรังสิต อำเภอธัญบุรี จังหวัดปทุมธานี 12110 ประเทศไทย
(168/16 Moo 1, Rangsit, Thanyaburi, Pathumthani 12110 Thailand)
Tel : [66] 20038911