

AD-8119

LABEL PRINTER

INSTRUCTION MANUAL

Instruction-AD-8119-v.1.c 92.08.10 OGA

LABEL PRINTER



Table of Contents

Compliance with FCC Rules	Page	iii
Introduction	Page	1
Welcome	Page	1
Features	Page	1
Unpacking Your AD-8119.....	Page	2
Best Conditions For Printing.....	Page	2
To Check the Clock.....	Page	2
Setting the Baud Rate for the A& D's Products.....	Page	3
Installing the Ink Ribbon Cartridge & Printer Paper	Page	3
Installing the Ink Ribbon Cartridge.....	Page	3
Installing the Printer Paper.....	Page	4
Keyboard	Page	5
Menu Operation Format	Page	7
Setting the Print Mode	Page	8
Connection to the Weighing Instruments	Page	9
Basic Operation	Page	11
Menu Operating Example	Page	11
Printing	Page	12
Memory	Page	13
Memory Registering	Page	13
Cancellation or Correction of the ID code	Page	16
Cancellation of the ID code	Page	16
Cancellation or correction of the product name	Page	16
Accessing Memory	Page	17
Accessing Memory Using the CODE key.....	Page	17
Connecting the FC Series Scale	Page	18
Memory Display and Printing	Page	19
Totaling Function	Page	21
Totaling Procedure	Page	21

Printing Totals	Page	23
Clearing Totals	Page	23
Other Settings	Page	24
Data Setting (Baud Rate, Data Bits, Interval).....	Page	24
Setting the Number of Copies to be Printed.....	Page	25
Enlarged Printing.....	Page	26
Setting the Date and Time	Page	27
Printing the Date and Time.....	Page	28
Selecting the Date Format	Page	28
Printing the Setting List	Page	29
Test Mode	Page	30
Error Display	Page	31
Dip Switches	Page	32
Specifications	Page	33
Appearance	Page	34



Compliance with FCC Rules

Please note that this equipment generates, uses and can radiate radio frequency energy. This equipment has been tested and has been found to comply with the limits of a Class A computing device pursuant to Subpart J of Part 15 of FCC rules. These rules are designed to provide reasonable protection against interference when equipment is operated in a commercial environment. If this unit is operated in a residential area it might cause some interference and under these circumstances the user would be required to take, at his own expense, whatever measures are necessary to eliminate the interference.

(FCC = Federal Communications Commission in the U.S.A.)



Introduction



Welcome!

*Thank you for your **A&D** purchase !*

This is an Instruction Manual for the AD-8119 Label printer. The AD-8119 is a product of years of design, development, and in-field testing. It is designed to withstand harsh environmental conditions - and each printer is subjected to several levels of quality control before it leaves the factory. Every care has been taken during the manufacturing process of this printer to ensure that it will perform accurately and reliably for many years .

The AD-8119 Label Printer is mainly for use with A&D's industrial scales, weighing indicators and electronic balances. The AD-8119 Label Printer is designed to receive data from A&D's optional RS-232C or current loop interface. The AD-8119 prints on special tack paper by means of the dot impact printing mechanism.

The highly reliable printer mechanism is perfect for industrial use, a watchdog circuit prevents malfunctioning and the AD-8119 is built solid to protect against noise influence. Easy to operate, the Label Printer provides fast dependable printing.



Features

- Can register product names by six-digit ID code and 26 alphanumerics in its 1,000 sample memory.
- The display uses a liquid crystal display made up of 5 x 7 dots, permitting easy operation while viewing the operation menu.
- Able to print 1,200 labels on the supplied tack printer paper.
- A lithium battery provides cumulative total and calendar backed-up without AC power for approximately two months.
- The weight data, counting data, ID code, product name, date and time can be printed in enlarged characters. You can print multiple copies of the same label by setting the number of copies.
- Cumulative total function by code.
- Calendar/clock function.



Unpacking Your AD-8119

Unpack the printer carefully and keep the packing material if you are likely to transport the printer again in the future.

In the carton you should find this manual plus :

- The Printer Ink Ribbon Cassette An AC power cable DIN Connector Fuse (1 A)
- Grounding Adaptor Tack Printer Paper (Fan-fold type)



Best Conditions For Printing

To ensure that you get the most from your printer, please try to meet the following " Best Conditions " as closely as possible.

- Don't install the AD-8119 in direct sunshine.
- Don't install the AD-8119 near heaters or air conditioners.
- Avoid places where there are sudden temperature changes, vibrations, strong winds and excessive moisture or dirt.

Also, keep away from conductive substances such as carbon powder. If these substances get inside the unit, errors can occur.

- The best temperature setting is about 20°C (68°F) at about 50% relative humidity.
- Be careful not to expose the unit to excessive noise or static electricity, this may cause malfunctioning.



To Check the Clock

Connect the AC cable to the printer, then turn ON the power.

The time and date will be displayed.

Check the date and time on the display. If it is not the current date and time, set the date and time correctly. (Refer to Page 26)

- The calendar/clock function is backed up for about two months, even if the power is OFF.



With AC power applied, the built-in battery is charged while the printer power is ON. At the time of purchase and if the printer power has not been used for two months or more, you should connect to AC and leave the printer power ON for one day or more. (With AC power applied, use of the printer will not impede the charging.)



Setting the Baud Rate for A&D Products

Set the data input baud rate for your A&D electronic balances, counting scales, weighing indicators, and platform scales to 2400 bps.



The baud rate for both A&D products and the AD-8119 must be the same. The AD-8119 Label Printer is set at 2400 bps at the factory. The products described below that are connected to the AD-8119 should normally also be set to 2400 bps.

The A&D Products which can be connected to the AD-8119

FX/FY Series, EPS Series, ERS Series, FCS Series, FR Series, FPS Series, AD-4321A/B, AD-4322A, AD-4323/4323B, AD-4324, AD4325 A/V, EK/EW Series, FV/FW Series



Installing the Ink Ribbon Cartridge & Printer Paper



Installing the Ink Ribbon Cartridge

- 1) Remove slack from the ribbon by turning the ribbon cartridge knob several times in the direction of the arrow.

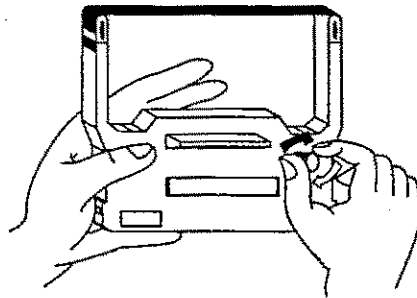

- 2) Insert the ribbon of the ribbon cartridge between the ribbon mask and the printing head of the printer, then press the ribbon cartridge down.

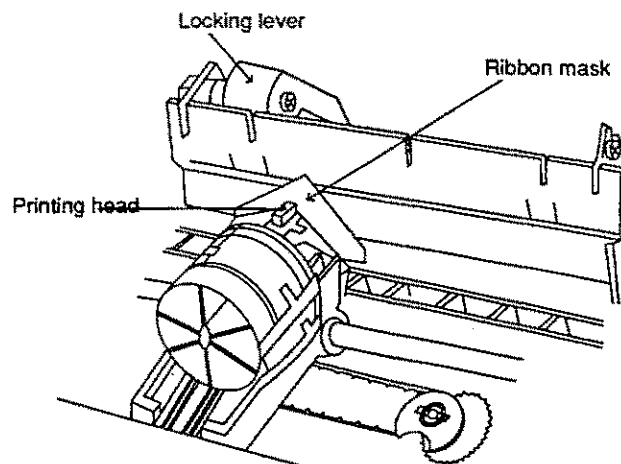

- 3) Check that it is properly set and that the ribbon advances normally, by turning the knob several times in the direction of the arrow. If it does not turn smoothly, remove it and insert it again. (Remove by pushing the ribbon cartridge to the left, then raising the right side.)

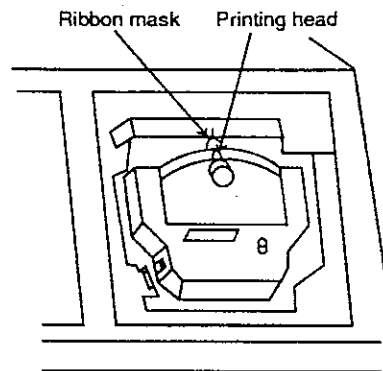

Installing the Printer Paper

- 1) Set the printer paper facing as shown in Fig. 1.

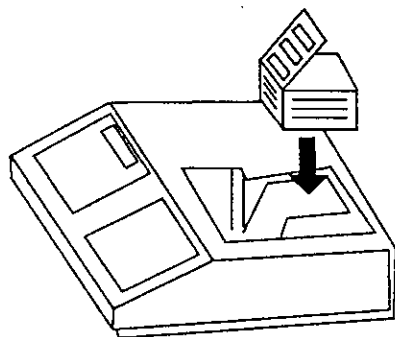
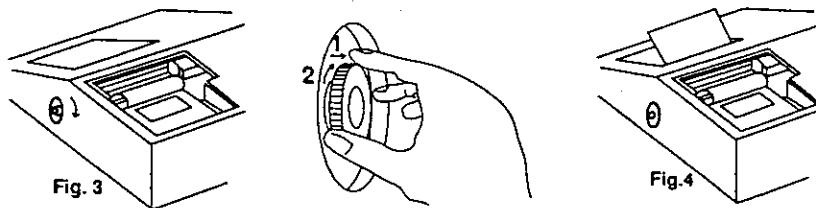
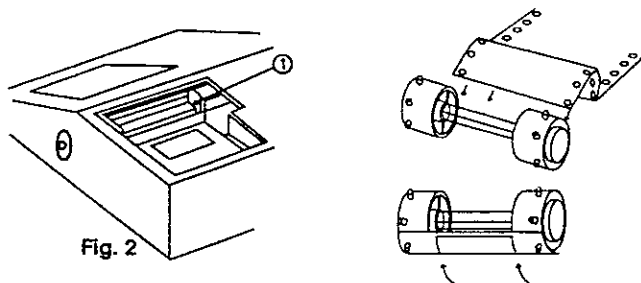

Fig. 1

- 2) Horizontally insert the printing paper in section 1) of Fig. 2 and pull out the printing paper by turning the knob in the direction of the arrow while pulling it out. (Figs. 2, 3, 4)



When the printer paper is not pulled out normally, push the top of the locking lever(Fig. 5) and pull out the printer paper by turning the knob in the counterclockwise direction while pulling it out, then install the printer paper again.

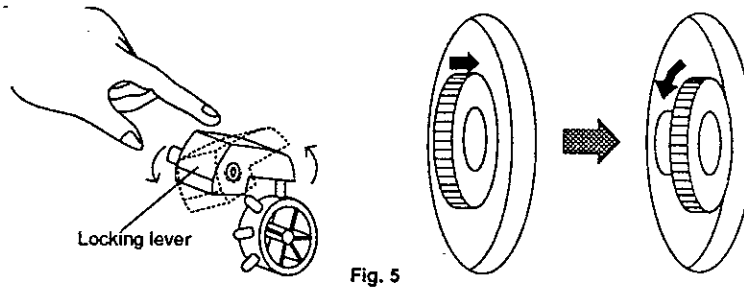

Fig. 5

You should normally return the locking lever, such that the knob cannot be turned in reverse. If the knob is turned in reverse when the printer paper is installed, labels may peel off and become entangled inside the printer.

- 3) Turn the knob while pulling it and match the top edge of the ink ribbon to the top edge of the label.



Keyboard

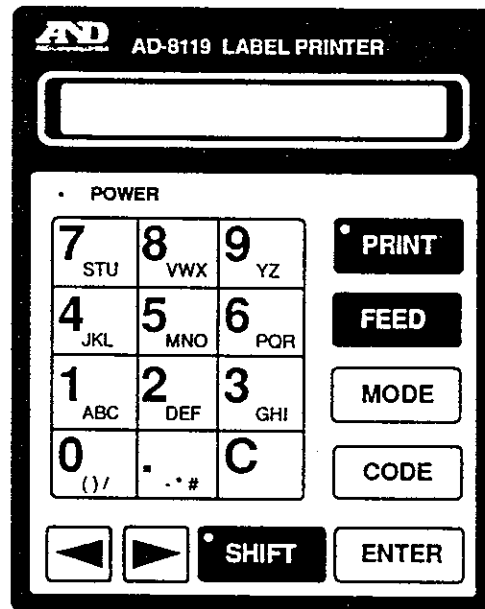

The PRINT Key

Press the **PRINT** key to print data.

- The operation will change depending on the printing mode.(Please see page 8 for more information concerning " Setting the Print Mode".)

The FEED Key

Press the **FEED** key to feed the printer paper.

- The **FEED** key will be disabled when it is on-line.

The MODE Key

Press the **MODE** key to change the printing mode. (Please see Page 7 for more information concerning " Various Setting Procedures")

The CODE Key

Press the **CODE** key to access the ID code. (Please see Page 17 for more information concerning" Memory Access")

The ENTER Key

Press the **ENTER** key to register various types of data.

The SHIFT Key

Press the **SHIFT** key to select either lowercase or uppercase.

The CURSOR Key

Press the **CURSOR** keys to move the cursor.



Various Setting Procedures (Menu Operation Format)

As we are making use of a menu operation format, the internal setting, registering and totaling are performed via the menu operation format below. The following items have been arranged on the menu. Refer to Page 29, "Printing the Setting List" for the various settings prior to factory shipment.

Total	Print	One ID		Prints the total value.
		All IDs		
	Clear	Clear One		Deletes the total value.
		All IDs		
	Wt.		Sets either to total or not to total the weight value and counting values.	
Ct.				
ID	Reg.			Records in the memory.
	List	Display		Displays and prints the memory that has been recorded.
		Print		
Func.	Data	Speed		Sets by matching the input data.
		Bit		
		Internal		
	Prnt	Trigger	Data	Sets the print mode.
			Key	
	Enlarge	Weight	Test	Tests the printer.
			Count	Indicates enlarged printing.
		Qty.		
	Misc.	Clock	Time adjust	Sets the date and time.
			Print	Sets whether or not to print the date and time.
		Date		Selects M/D/Y \longleftrightarrow D/M/Y.
	List			Prints the current setting list.



Setting the Print Mode

Select one of the following, matched to your particular usage.

Step (1) Data print mode

When you print using the Print key or Auto-Print mode of the A&D weighing instruments that can be connected to this unit.

Step (2) Key print mode

When printing using the printer's **PRINT** key.

NOTE: Normally step (1) is used, but use step (2) when you wish to print using the print key of this unit or when the A&D balances or scales such as the EK/EW series or FV/FV series do not have a Print key or Auto-Print mode.

Setting:

When used in the Data Print mode in step (1)

- 1) Setting of the A&D weighing instruments (excluding the EK/EW and FV/FW series) connected to the printer

Set the data output setting of the weighing instruments connected to the printer to Key Print mode or Auto-Print mode.

- 2) Printer setting

The setting has been done prior to factory shipment.

The setting procedure is as follows:

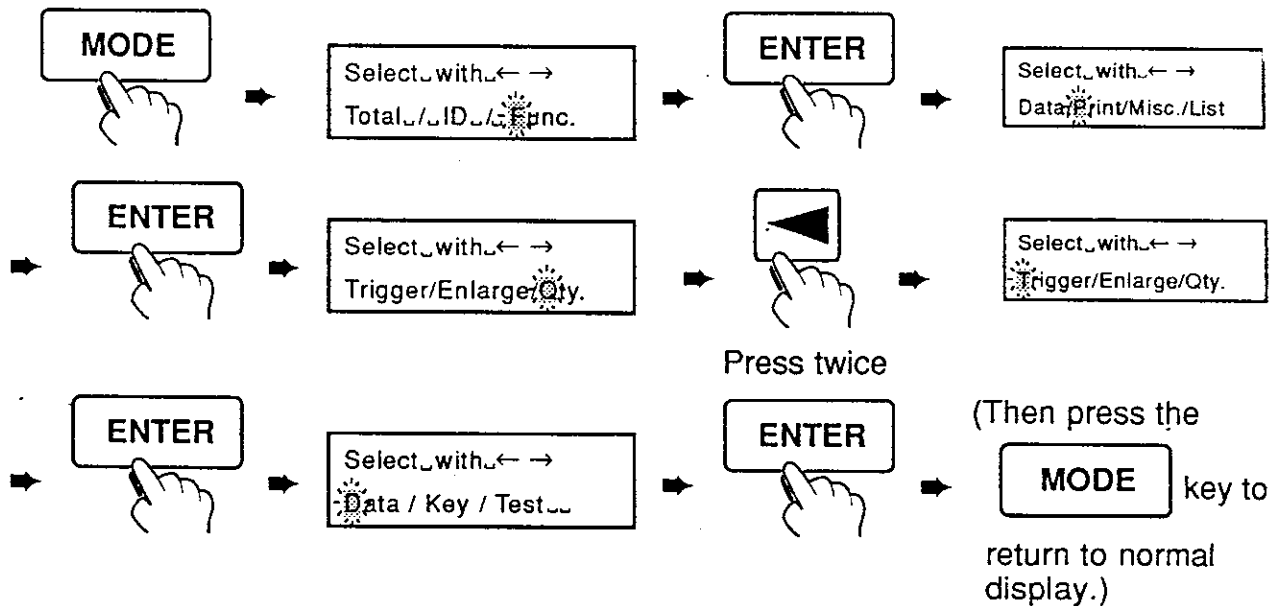

```

ID_CODE 000000
01/04/92 12:30 PM
  
```

Normal display

When used in the Key Print mode of step (2)

- 1) Setting of the A&D weighing instruments connected to the printer

Set the data output setting of the weighing instruments connected to the printer to the Stream mode.

When the weighing instrument that will simultaneously output multiple data is connected to the printer, set the data output to the single kind of weight data.

- 2) Printer setting

The setting procedure is as follows:

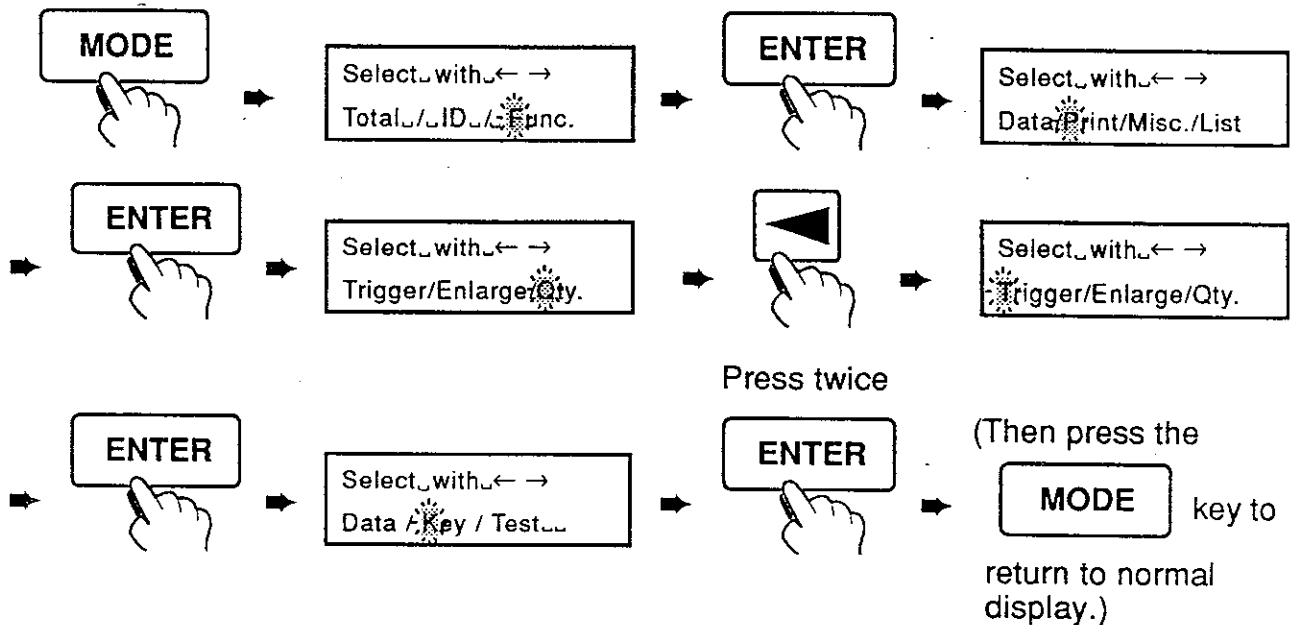

ID_CODE 000000
01/04/92 12:30 PM

Normal display



Connection to the Weighing Instruments

The connecting procedure is as follows:

- (1) Turn off the power of both the weighing instruments and the printer prior to connection.
- (2) Connect the RS-232C output of the weighing instrument to the RS-232C input of the AD-8119. When a current loop output is to be used with the weighing instruments, you can connect the current loop output to the current loop input of the printer.

You may use either the RS-232C or the current loop.

Weighing instruments

- FX/FY Series
- EP Series
- ER Series
- FC Series
- FR Series
- FT Series
- FP Series
- AD-4321A/B
- AD-4322A
- AD-4323/4323B
- AD-4324
- AD-4325A/V

*Connection cables
 RS-232 :KO:445 (A&D standard)
 Current loop:KO:359 (A&D standard)

EK/EW Series	RS-232C	KO:445 (A&D standard)	} Controlled on AD-8119 side only.
	(Current loop not permitted)		
FV/FW Series	RS-232C	KO:577A (A&D standard)	
	(Current loop not permitted)		

A product equivalent to the KO:359 can be produced using the DIN connector that is respectively supplied with the printer and the weighing instruments.

(The DIN connector for the weighing instruments may sometimes be the accessory of the serial interface.)

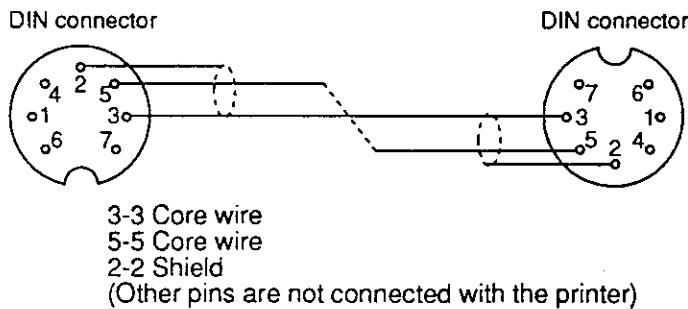



Basic Operation



Menu Operating Example

Here, we will explain the menu operation using an example of "deleting all the totals."

In this case select the menu for "Total" - "Clear" - "All IDs."

<u>Total</u>	Print	One ID	Prints the total .
		All IDs	
	<u>Clear</u>	Clear One	Deletes the total .
		<u>All IDs</u>	
Wt.	Sets either to total or not to total the weight values and the counting values.		
Ct.			

If the menu is displayed, press the **MODE** key. Normal display comes on.

```

ID_CODE *****
** ** ** ** ** ** **

```

Step1. Press the **MODE** key. The initial menu will be displayed.

```

Select with ← →
Total / ID / Func.

```

Step2. Select " Total".

Set the cursor to " Total" using the **◀** key, then press the **ENTER** key.

```

Select with ← →
Total / ID / Func.

```

Step3. The " Total " menu will be displayed.

```

Select with ← →
Print / Clear / wt. / ct.

```

Select " Clear ", then press the **ENTER** key. The " Clear " menu will be displayed.

```

Select with ← →
Clear One ID / All IDs

```

Step4. Select " All IDs" using the **◀** key, and press the **ENTER** key.

```

Select with ← →
Clear One ID / All IDs

```

Press the **1** **ABC** key to delete "All IDs".

(If you stop deleting "All IDs ", press the **0** **() /** key.)

When either Y=1 or N = 0 has been selected, the display screen returns to the screen shown below.

Select with ← →
Print / Clear / wt. / ct.

NOTE: In this way you are verifying with a Yes or No, when deleting and rewriting important data.

Return to the normal display using the **MODE** key.

(Press the **MODE** key to interrupt during setting. The display will then return to the normal display.)

ID_CODE 000000
01/04/92 12:30 PM



Printing

The printing operation varies depending on the printing mode.

(1) When the print mode is in the " Data Print Mode ", change over between **ON-LINE / OFF-LINE** using the **PRINT** key.

Step1. Press the **PRINT** key to set the ON-LINE setting.

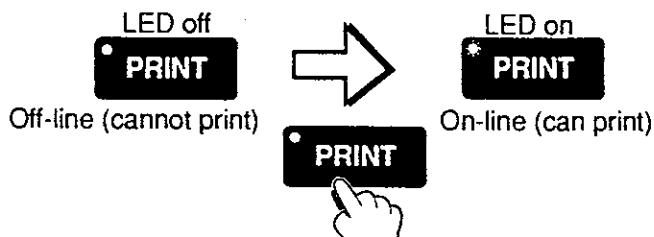

Step2. Print by pressing the 'print' key of the weighing instrument (or set the internal setting of the weighing instrument to the Auto Print Mode).

Printout Example

Count	1986 PC
Weight	1.1105 kg
Unit weight	5.5921 g
92/03/28 03:03 PM	

(2) When the print mode is in the "Key Print Mode", print by pressing the **PRINT** key of the AD-8119.

NOTE: When the weight value has not stabilized, it will not print, but rather will display as follows:

When unstable: Unstable

When over-loaded: Overload

At such times, if you press any key, the screen will return to the original display.

Weight	100.0 kg
92/03/28 03:03 PM	



Memory



You can register product names using up to a 6-digit ID code and up to 26 alphanumerics.



Memory Registering

We will explain "Memory Registering" using an example of registering "UA3" in the ID code no. 123.

Step. 1 Press the **MODE** key and the initial menu will be displayed.

Select with ← →
Total / ID / Reg / List

Step. 2 Select "ID" using the **◀** key, and press the **ENTER** key. The screen shown below is displayed.

Select with ← →
ID / Reg / List

Step. 3 Then, press the **ENTER** key and you can input 1,2,3 from the alphanumeric key pad.

ID_? *

ID_?123 *

Step. 4 After inputting the ID code, press the **ENTER** key. The display shown below will appear.

ID000123
* *

Step. 5 Next use the alphanumeric key pad and the **SHIFT** key to enter product names.

Select lowercase or uppercase using the **SHIFT** key.

- The alphanumeric have been assigned to the alphanumeric key pad and they are changed in the following sequence.

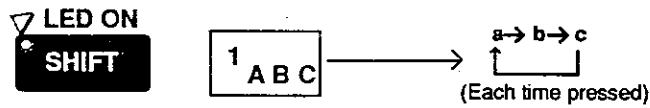
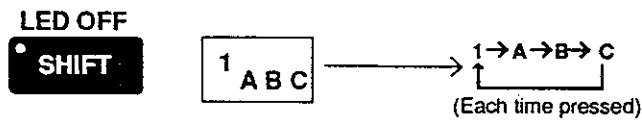

- The letter on the cursor is recorded by pressing any other numeric key and the cursor moves to the next digit.
- Use the cursor key when repeatedly using the same key or when entering spaces.

Alphanumeric key pad Table

Key	LED OFF			LED ON During the SHIFT key is pressed			
		SHIFT					
1	1	A	B	C	a	b	c
2	2	D	E	F	d	e	f
3	3	G	H	I	g	h	i
4	4	J	K	L	j	k	l
5	5	M	N	O	m	n	o
6	6	P	Q	R	p	q	r
7	7	S	T	U	s	t	u
8	8	V	W	X	v	w	x
9	9	Y	Z		y	z	
0	0	()	/			
.	.	-	*	#			

The procedure on the next page is an example of registering the product name (UA3) and its ID code (1 2 3).

Example of registering the product name

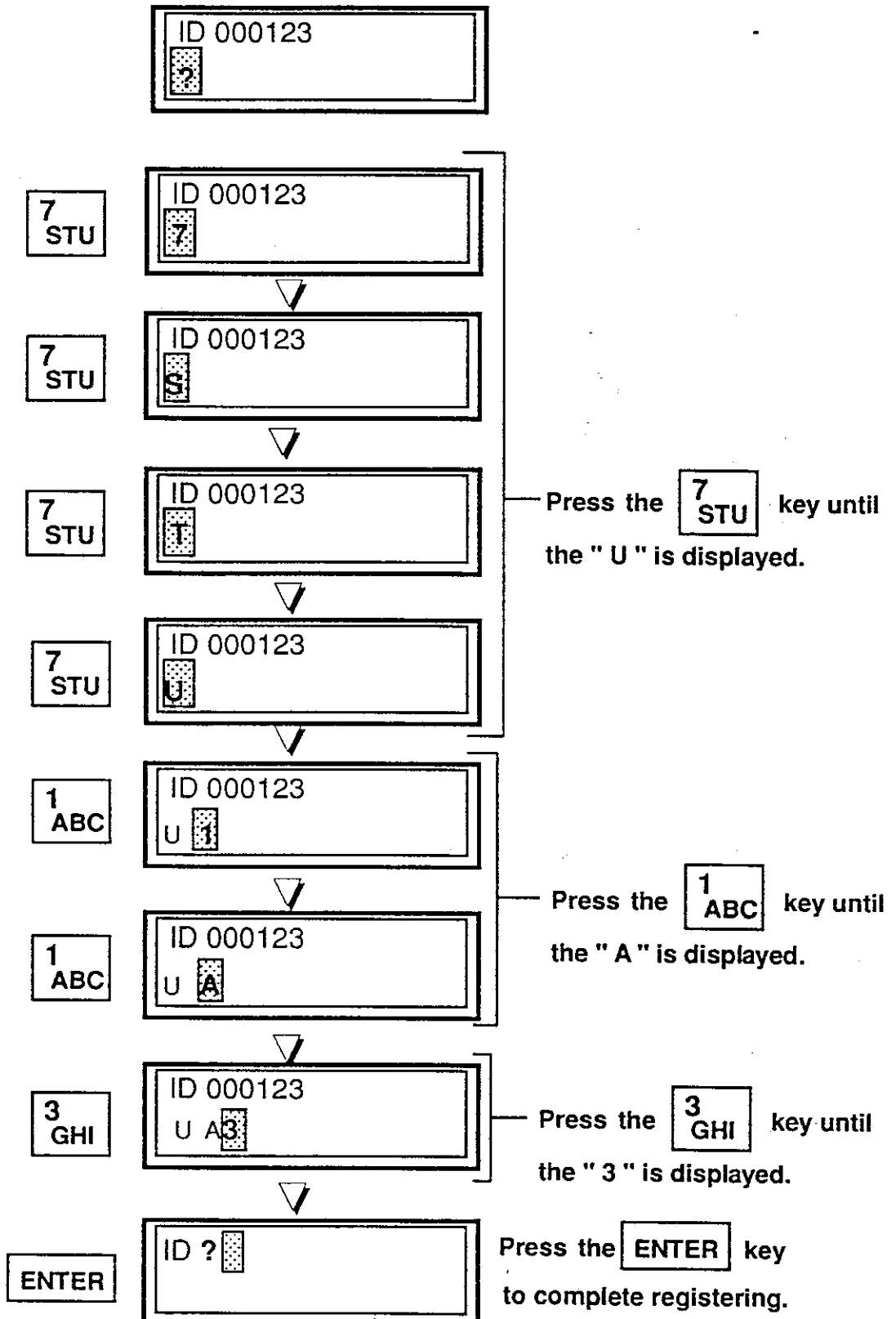

Now, you can register again, if you wish, using the same procedure.

The screen will return to the normal display if the **MODE** key is pressed.



Cancellation or Correction of the ID code



Cancellation of the ID code

Cancellation of the ID code during registering can be performed by pressing the **C** key, but the entire ID code number will be deleted as shown in the following figure.

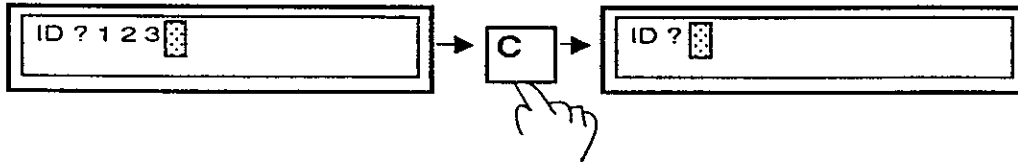

Cancellation or correction of the product name

You can cancel or correct the product name during registering as shown in the figure below using the **◀** / **▶** keys and **C** key.

○ When deleting all the alphanumeric of the product name

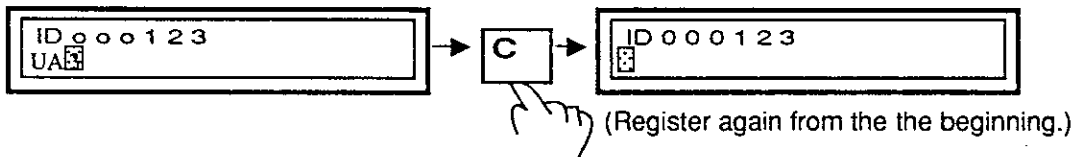

○ When correcting part of the alphanumeric of the product name

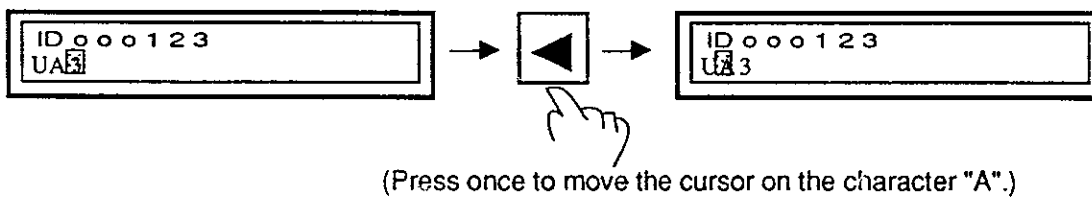

Then, when changing "A" to "E" for example, press the **2 DEF** key until the "E" is displayed.

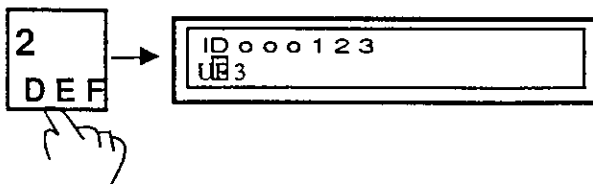



Accessing Memory



When printing, the ID code and product name can be printed together with the weighing data by accessing the registered memory.

Press the **CODE** key for memory access. (When the AD-8119 is connected to the FC Series, which is one of the A&D counting scales, you can access the memory without pressing the **CODE** key.)



Accessing Memory Using the CODE key

Step.1 When the menu screen is displayed, press the **MODE** key for the normal display.

```
ID_CODE 000000
917/12/18/ 11:00 AM
```

Step.2 Press the **CODE** key and enter the ID code of the registered memory to be accessed, then press the **ENTER** key.

```
ID ? → ID ? 1 2 3
```

1 ABC 2 DEF 3 GHI

ENTER

For example, enter "1", "2", "3" and press the **ENTER** key.

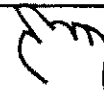

Step.3 The ID code will be recalled.

```
ID_CODE 000123
917/12/18/ 11:05 AM
```



When the ID code "0" is recalled, the AD-8119 will print the weight data only. (Neither ID code nor the product name can be printed.)



Connecting the FC Series Scale

You can also recall the ID code number for the FC series counting scale.

- ▶ Set the Print Mode Setting to the " Data Print Mode " (See Page 8) .

On the FC series scale, always select the ID number to be sent by keying in a " / " in the internal setting, Data to be Sent (F - 6 - 2) and also set the Data Format (F - 6 - 3) to " 2 " .

See " Data Output " on page 7•13 in the Instruction Manual for the FC Series.

- ▶ If the printout is performed using the PRINT key on the FC scale after counting has completed, a product name with the same ID number as that of the FC scale will be printed.

If an ID number that is the same as the FC ID has not been registered in the AD-8119, only the ID number will be printed. Store an ID number that is the same as the FC ID number into memory of the AD-8119.

Memory Display and Printing

The registered memory can be partially or entirely displayed and printed.

Step.1 Press the **MODE** key to display the " Total " menu and select " ID ".

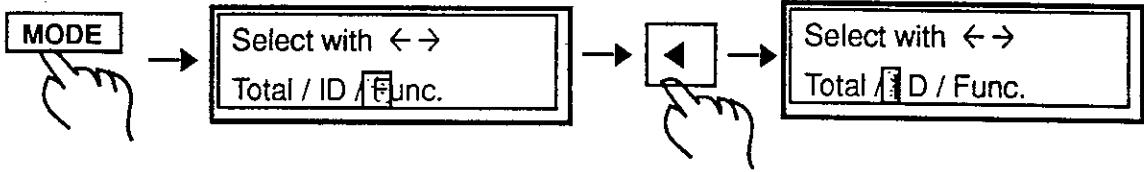

Step.2 Press the **ENTER** key and select " List ".

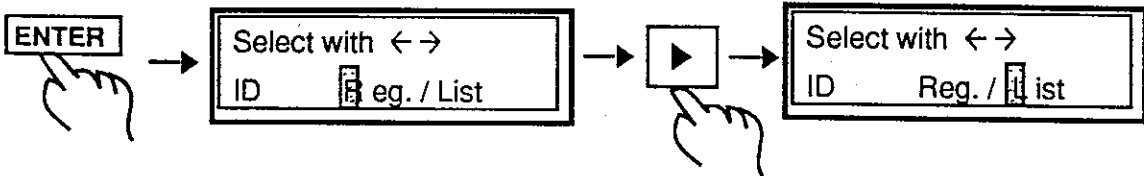

Step.3 Press the **ENTER** key to display the " List " menu and select " Display ", then press the **ENTER** key again. The next screen will be displayed.

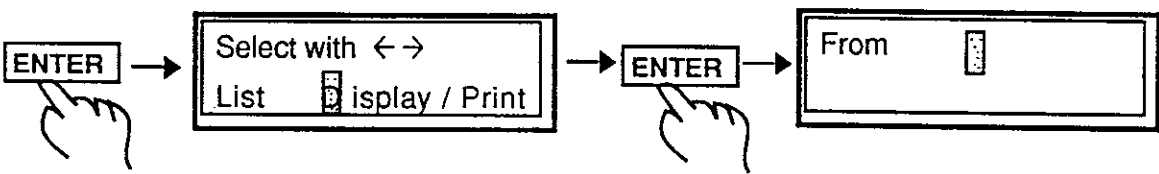

Press the **C** key to stop momentarily, then press the **C** key again to release the momentary stop.

- When you want the product name for one ID to be displayed, enter the ID code, for example, 1, 2, 3.

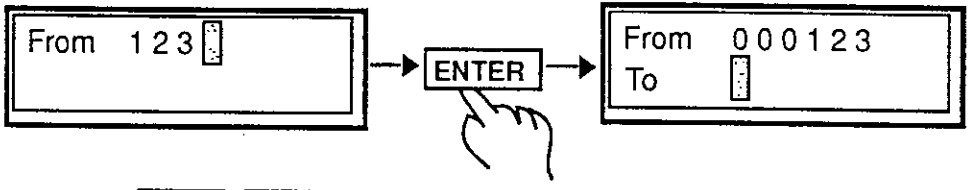

→ For example, enter " 1 ", " 2 ", " 3 " and press the **ENTER** key.

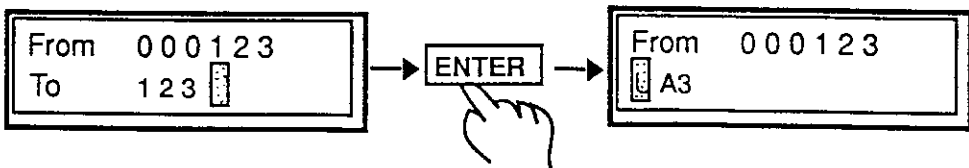

(Displays for about 2 seconds.)

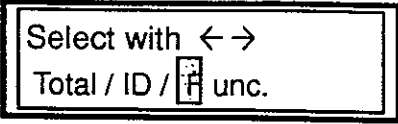

Then press the **MODE** key to return to the normal display.

- In step 3, if the **ENTER** key is pressed without entering the ID code, 000001 will automatically be displayed.

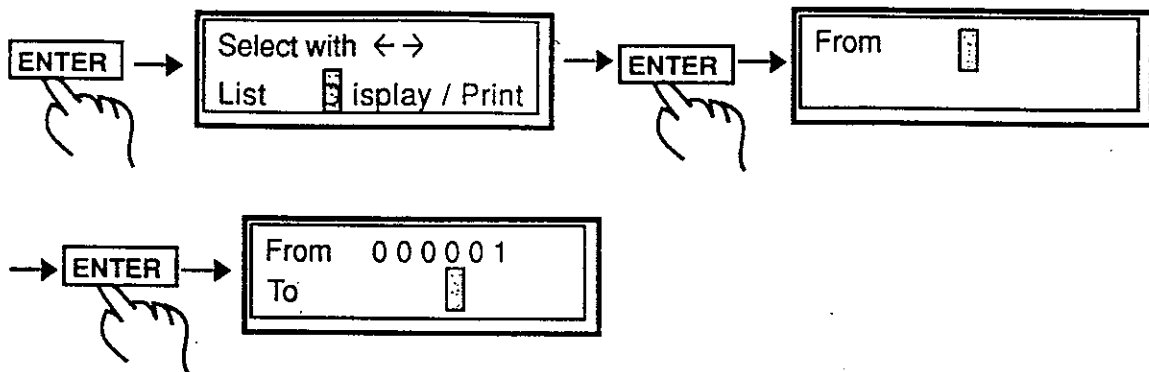

Thereafter, if the **ENTER** key is pressed again without entering the ID code, the registered ID codes will be displayed in sequence.

- In step 3, decide the range of the ID codes for the product names you want to display, then enter the ID code. (For example, from the IDcode, 123 to the ID code, 456)

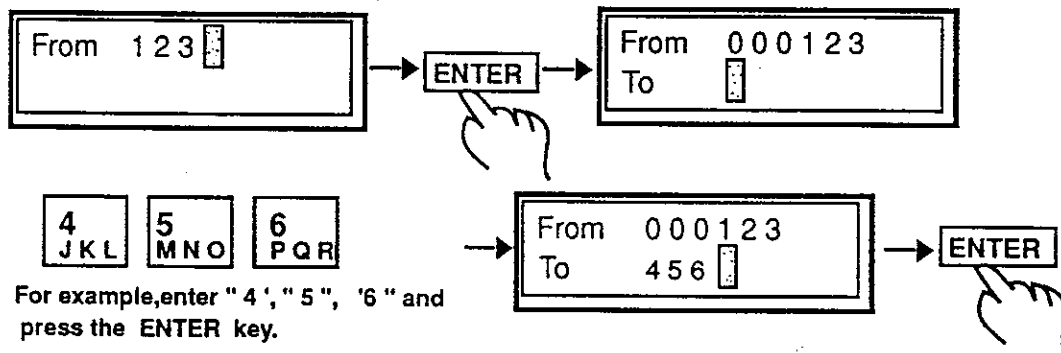

For example, enter "4", "5", "6" and press the **ENTER** key.

The ID codes and product names will successively be displayed.



When you want to correct the IDcode during entry, you can correct the ID code that has been entered if you press the **C** key prior to pressing the **ENTER** key.

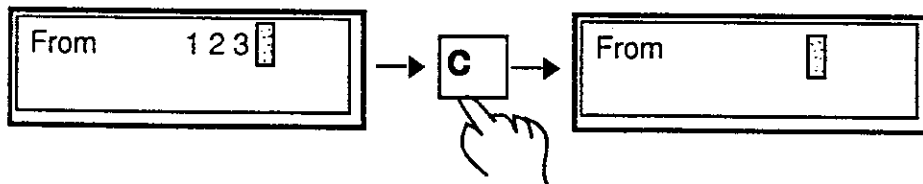



Totaling Function



Total the weight and counting data by the ID code.

The ID codes that can be used for the total function are 1 to 50.

You can respectively select whether or not to total the weight data or the counting data.



Totaling Procedure

- Select to total or not to total the weight data according to the procedure below.

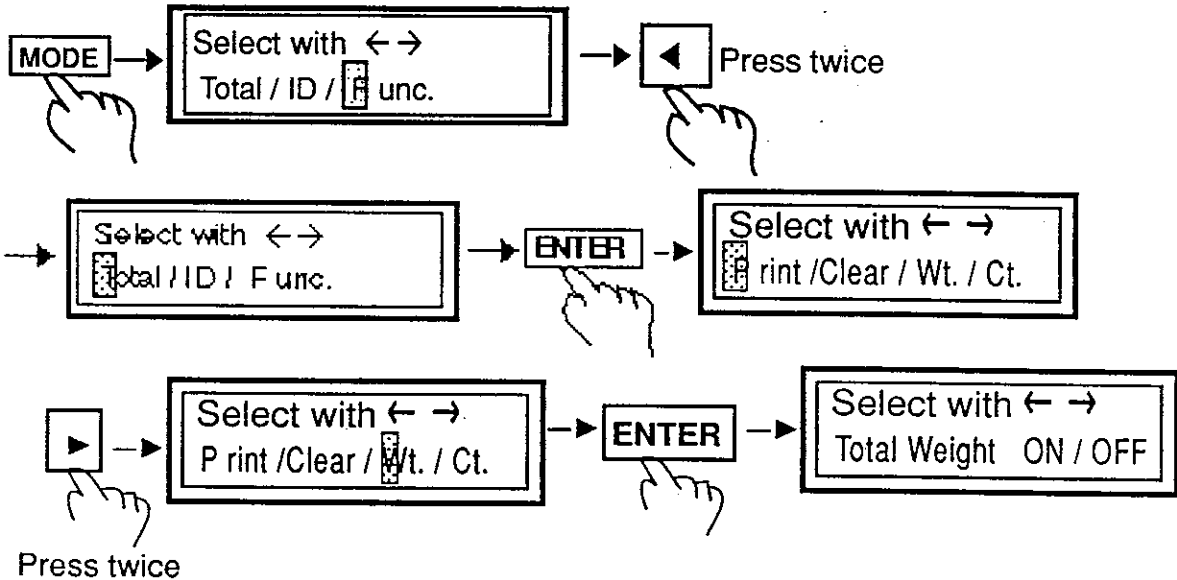

When you wish to total the weight data, select " ON " pressing the key.

When you do not wish to total the weight data, select " OFF " pressing the key.

Then, press the **ENTER** key.

The screen will return to the display shown below.

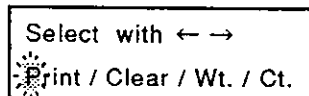

If you want to return the screen to the normal display, press the **MODE** key.

- Select to total or not to total the counting data according to the procedure below.

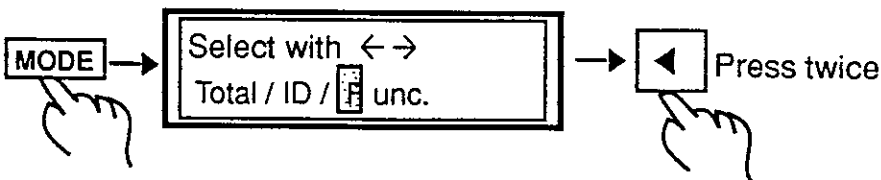

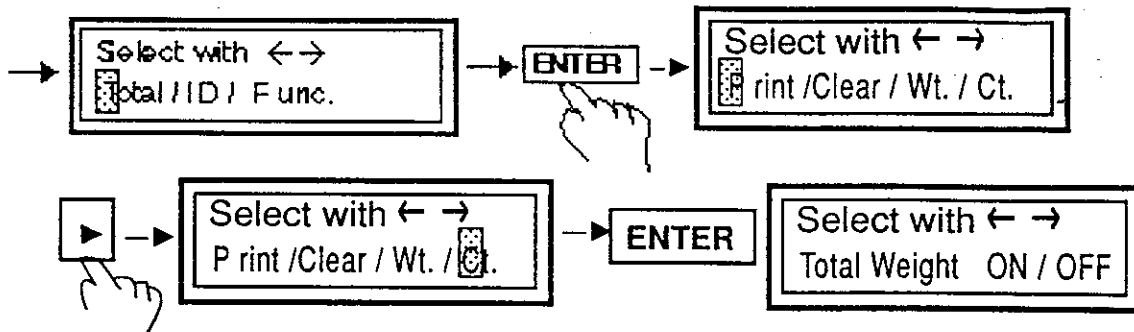

Press three times

When you wish to total the counting data, select " ON " pressing the key.
When you do not wish to total the counting data, select " OFF " pressing the key.

Then, press the **ENTER** key.

The screen will return to the display shown below.

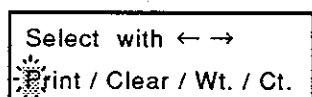

If you want to return the screen to the normal display, press the **MODE** key.

- When you recall the ID code to be totaled, the weight data or counting data will be added to the weight data or counting data that has been stored in the current ID code.



When changing the models of the A&D weighing instruments connected to the printer, you cannot total by continuing on with the total value accumulated up to that point. The same applies when units and decimal points have been changed.



When totaling the data of the A&D weighing instruments connected to the printer that output the data broken down by gross weight and net weight, you should output the net weight. The gross weight cannot be totaled.



Printing Totals

Step.1

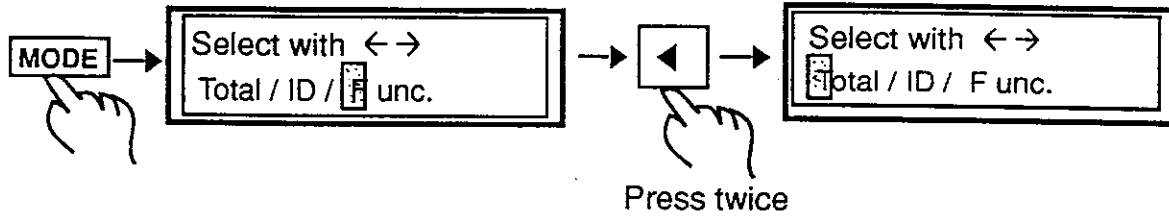

Step.2

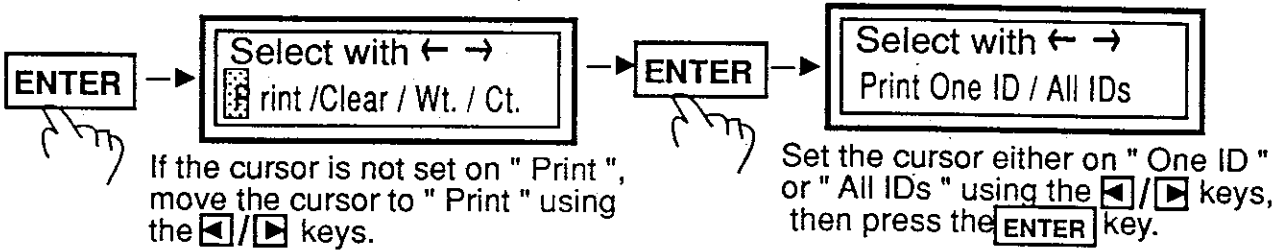

Print **One ID** : Prints the total value for only the specified ID code.
Print **All IDs** : Prints the total value for all the ID codes.

○ When "Print One ID" has been selected.

When is displayed, enter the ID code for the total value to be printed using the alphanumeric keypad, then press the **ENTER** key.

Press the **C** key when you make a mistake in entering the ID code, then will be displayed again.



Clearing Totals

Step. 1

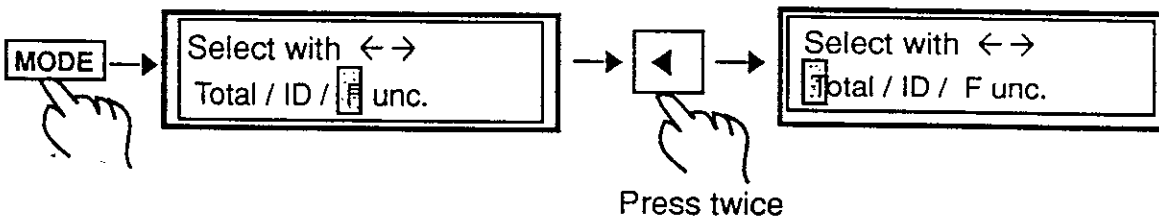

Step. 2

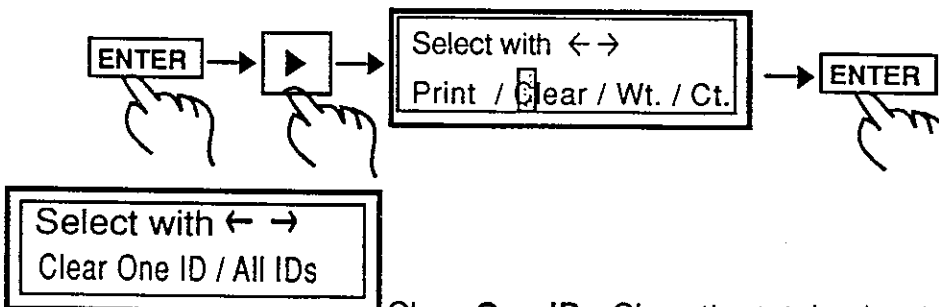

Clear **One ID** : Clear the total value for only the specified ID code.

Clear **All IDs** : Clear all the total values.

Select using the ◀ / ▶ keys, then press the **ENTER** key.

○ When " Clear One ID " has been selected.

When **ID ?** is displayed, enter the ID code for the total value to be cleared using the alphanumeric keypad, then press the **ENTER** key.



Other Settings



Data Setting (Baud Rate, Data Bits, Interval)

The procedure shown below describes the method of setting or changing the baud rate, data bits and interval time. Select the baud rate, data bits and interval time according to the input data specifications.

Step.1

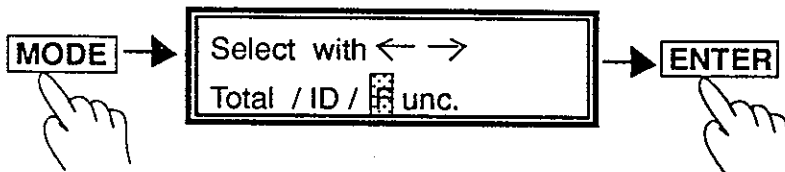

Step.2



Set the cursor on " Data " using the ◀ / ▶ keys.

- If you will not change the data, press the **0** key.
- If you want to change the data, press the **1** key.

Speed (Baud Rate): 600 / 1200 / 2400 / 4800 / 9600 bps

Bit (Data Bits) : 7 bits / 8 bits

Interval time: 0.5 / 1.0 / 1.5 / 2.0 seconds

Interval : Becomes valid when the print mode is set to 'data'. After one group of data has been entered, if the time interval until the following data group appears is shorter than the time set, the data group is included and printed on one sheet of tack paper. If the second data group does not appear by the end of the time set, it may be assumed that the first data group is completed.

(2400 bps, 7 bits and 2.0 seconds are the factory settings.)



Set the cursor on the desired baud rate using the ◀ / ▶ keys and press the **ENTER** key.

- Also when the " Bit "(data bit length) and " Interval "(interval in which the data is sent) are to be set, select the numbers for the " Bit " and for the " Interval " by setting the cursor on " Bit " or " Interval " using the ◀ / ▶ keys then press the **ENTER** key. Hereafter, when the **MODE** key is pressed, the screen will return to the normal display.

Setting the Number of Copies to be Printed



You can set the number of copies of the same label to be printed by setting the number of copies to be printed. (1 to 999 copies)



When printing the date and time, all the labels will have the same date and time.

Step.1 Setting the number of copies to be printed.

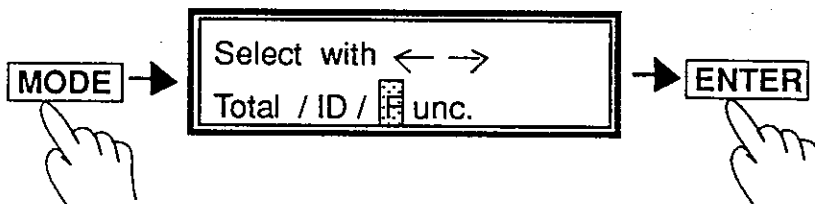

Step. 2

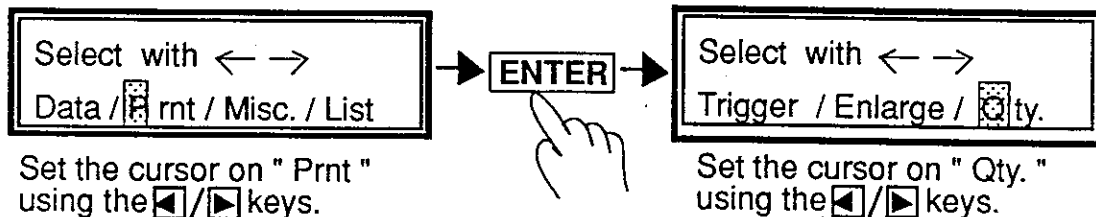

Press the **ENTER** key.

Step.3 Enter the number of copies to be set using the alphanumeric keypad, then press the **ENTER** key.

To make a correction, press the **C** key before pressing the **ENTER** key, then enter the correct number of copies and press the **ENTER** key.

Qty. ?

Enlarged Printing



You can specify enlarged printing respectively for the weight value and the counting value.

Example of enlarged printing procedure of the counting value.

Step.1

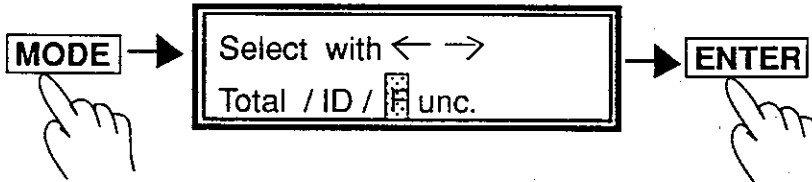

Step.2



Set the cursor on "Prnt" using the / keys.

Set the cursor on "Enlarge" using the / keys.

Step.3

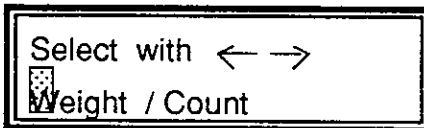

Select the items to be enlarged using the / keys then press the **ENTER** key.

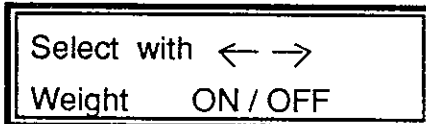

When the "Weight" has been selected.

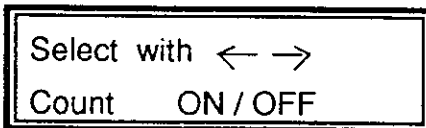

When the "Count" has been selected.

Select ON or OFF using the / keys then press the **ENTER** key.

ON : For enlarged printing
OFF : For non-enlarged printing

Press the **MODE** key to return to the normal display.

Setting the Date and Time



The date and time are set prior to shipment.

The built-in battery permits it to be maintained for about two months, even with the power off. (When the battery is fully charged.)

Step.1

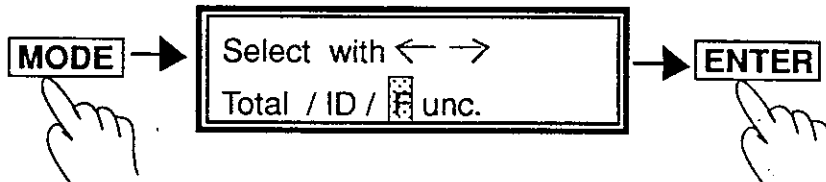

Step.2





Set the cursor on "Misc. " using the  /  keys.

Set the cursor on "Clock " using the  /  keys.

Step.3





- If you do not want to change the date, press the **ENTER** key.
- If you want to change the date, set the cursor on the spot you want to change using the  /  keys and enter the appropriate number, then press the **ENTER** key.

Step. 4 Set the time.

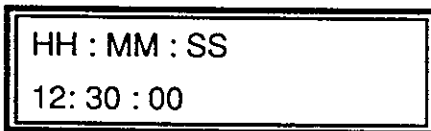
- If you do not want to change the time, press the **ENTER** key.



- If you want to change the time, set the cursor on the spot you want to change using the  /  keys and enter the appropriate number. To change the AM and PM setting, set the cursor on it, then press the **SHIFT** key. Press the **ENTER** key when the changes have been completed..

Printing the Date and Time



Set either to print or not to print the date and time when printing.

Step. 1

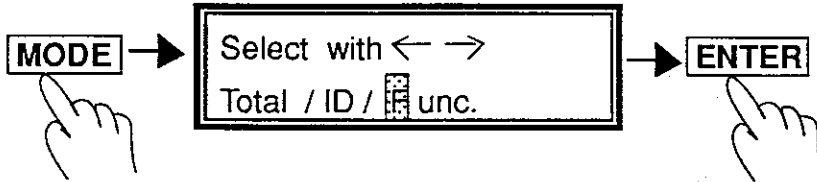

Step. 2



Set the cursor on "Misc. " using the / keys.

Set the cursor on "Clock " using the / keys.

Step. 3



Set the cursor on "Print " using the / keys.

Select ON or OFF using the / keys, then press the **ENTER** key.

ON : To print the date and time
OFF : Not to print the date and time

Selecting the Date Format



You can select the Date format.

Select either **M / D / Y** format or **D / M / Y** format.

Step. 1

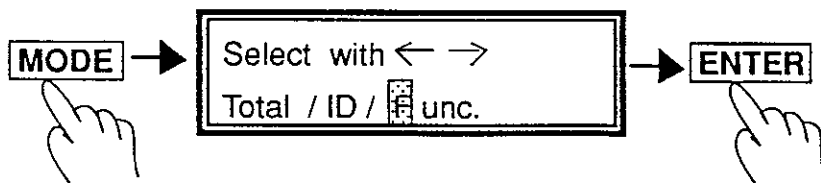

Step. 2



Set the cursor on "Misc." using the / keys.

Set the cursor on "Date " using the / keys.

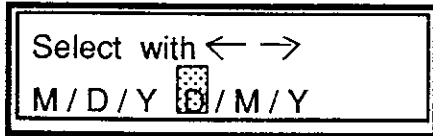

Select using the / keys and press the **ENTER** key.

Thereafter press the **MODE** key to return to the normal display.

Printing the Setting List



You can print a list of the current settings.

Step. 1

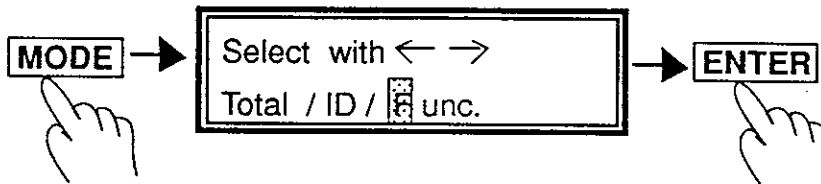

Step. 2

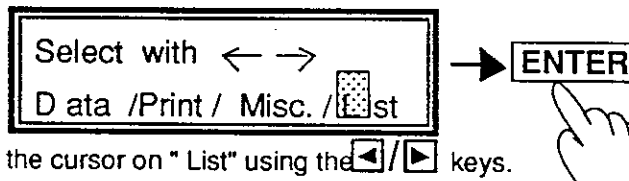

Set the cursor on " List" using the / keys.

Select using the / keys, then press the **ENTER** key.

Example: The setting list of the factory setting

Total	Weight	OFF
	Count	OFF
Func.		
Data	Speed	2400
	Bit	7 BIT
	Timer	2.0
Print	Trigger	Data
Enlarge	Weight	OFF
	Count	OFF
Qty.		1
Time		ON
Date		M / D / Y

Test Mode



This is the mode for testing the keys and printing.

Step. 1

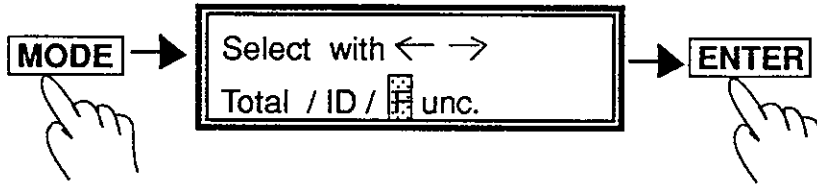

Step. 2

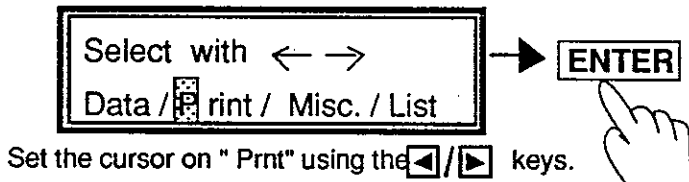

Step. 3

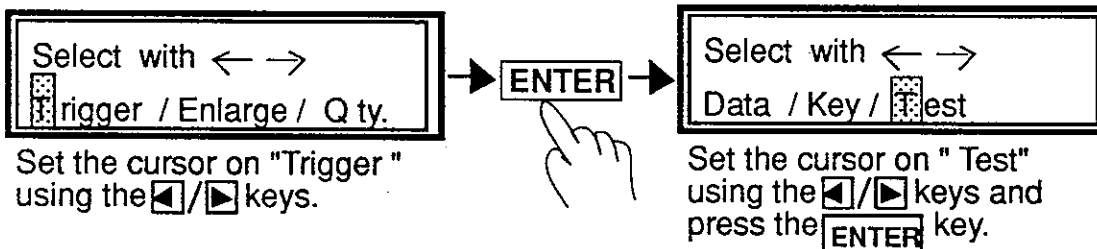

The test printing shown below will be performed.

key		shift	key		shift
1	ABC	abc	6	PQR	pqr
2	DEF	def	7	STU	stu
3	GHI	ghi	8	VWX	vwx
4	JKL	jkl	9	YZ	yz
5	MNO	mno	0	()/	
.	-*#				

```
!! TEST MODE !!
31 / 08 / 92 12 : 30 PM
```

Display screen

Step. 4

Press the keys and each key will be checked as follows;

PRINT KEY OK FEED KEY OK MODE KEY OK CODE KEY OK
 ENTER KEY OK '0' KEY OK '1' KEY OK '2' KEY OK

○ The test mode is terminated by turning off the power.



Error Display



The display advises you when errors are detected upon printing.

<div data-bbox="240 443 596 539" data-label="Text"> <p>ID_CODE ***** Paper empty</p> </div> <p data-bbox="233 544 691 577">The buzzer will sound continuously.</p>	<p data-bbox="826 450 1208 551">There is no printer paper. Install the printer paper, then press any printer key.</p>
<div data-bbox="240 651 596 748" data-label="Text"> <p>Communication error 03 / 09 / 92 06:55 PM</p> </div> <p data-bbox="233 752 596 786">When print mode is " data " .</p> <p data-bbox="233 790 786 857">When the MODE key is pressed twice, the screen will return to the normal display.</p> <div data-bbox="240 875 596 972" data-label="Text"> <p>Communication error !! push any key !!</p> </div> <p data-bbox="252 976 604 1010">When print mode is " key " .</p>	<p data-bbox="826 707 1193 801">Improper communication. Check the baud rate and the cable connection.</p>
<div data-bbox="240 1055 596 1151" data-label="Text"> <p>No Data !! push any key !!</p> </div> <p data-bbox="233 1155 759 1189">The buzzer will sound for about 1 second.</p>	<p data-bbox="826 1043 1305 1234">Data cannot be received. Check the cable connection. When used in the key print mode, check the baud rate. Press any key to return to the normal display.</p>
<div data-bbox="240 1256 596 1352" data-label="Text"> <p>ID_CODE ***** Unstable</p> </div> <p data-bbox="233 1357 759 1391">The buzzer will sound for about 1 second.</p>	<p data-bbox="826 1267 1225 1402">Data is unstable. Press any key to return to the normal display. Unstable data cannot be printed.</p>
<div data-bbox="240 1424 596 1520" data-label="Text"> <p>ID_CODE ***** Over load</p> </div> <p data-bbox="233 1525 759 1559">The buzzer will sound for about 1 second.</p>	<p data-bbox="826 1435 1270 1570">The weighing value is over the maximum capacity. Press any key to return to the normal display.</p>



Dip Switches



The setting of the dip switches is read when the power is ON.
If you change the setting of the dip switches you set before, turn off the power first, set the dip switches, and turn on the power again.

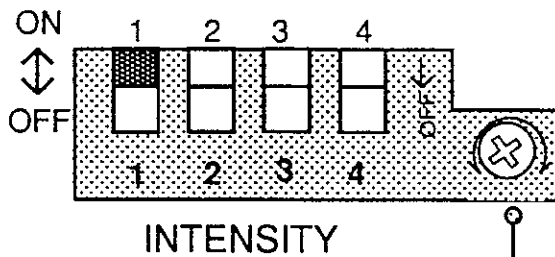

SW 1	ON is fixed. Donot turn it OFF.		
SW 2	Dump print mode	ON : Dump print mode	OFF : Normal mode
	During the dump print mode, input data is printed as it is. All keys except both the PRINT and FEED keys are invalid.		
	PRINT	Used when changing the mode between ON-LINE and OFF-LINE. ON-LINE: Data is printed. OFF-LINE: Data is not printed.	
	FEED	Used when feeding the printer paper.	
SW 3	Regular printer paper print mode	ON: Regular printer paper mode (PP-108) When in the regular printer paper (PP-108) mode, printer paper cannot be fed after printing.	
		OFF: Tack printer paper mode.	
SW 4	Initializing	ON: performing the initialization.	OFF : During normal use.
	If initialization is performed, the items below are performed. * Deletes the memory. * Deletes the total values. * Initializes the internal settings. (Will return to the factory settings.)		

○ INTENSITY

Adjust as illustrated shown below when the display is vague. It will become clearer by turning the screwdriver clockwise.

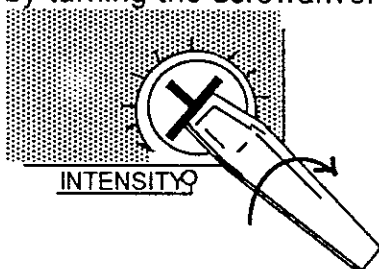



Specifications

Printer Specifications	
Printing system	Mechanical type dot impact printer
Printing width	5 x 7 dot matrix
Printing speed	Approximately 3.3 lines/second (internal processing time excluded)
Dimensions of characters	1.5 (W) x 2.4 (H) mm
Ink ribbon	
Color of characters	Black
Life	Approx. 2.6 million characters (varies depending on environment)
Printing paper	
Specified tack paper(PP-139)	88.9 X 152.4 (mm) 400 sections(1 section : tack paper (63.5 mm x 38.1 mm) x 3 sheets)
Regular paper(PP-108)	88.9 x 152.4 (mm) 500 sections

General Specifications	
Power supply	100, 117, 220, 240V AC +10% / -15%, 50/60 Hz During standby: Approx. 5VA During continuous printing: Approx. 20VA
Weight	Approximately 6.3 kg
Operating temperature range	0°C to 40°C (32°F to 104°F)
Storage temperature range	-10° to 60°F (14°F to 140°F)
Maximum humidity	80 %RH (non-condensing)
Dimensions	290 (W) x 350 (D) x 121 (H) mm

Input Specifications	
Method	EIA RS-232C or 20 mA current loop (Active)
Type	Asynchronous, receive only
Baud rate	600/1200/2400/4800/9600 bps (A current loop is up to 2400 bps)
Data bits and Parity bit	7 bits, Even parity 8 bits, No parity
Stop bit	1 bit
Codes used	ASCII



Appearance

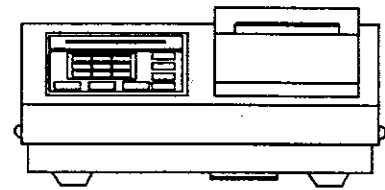
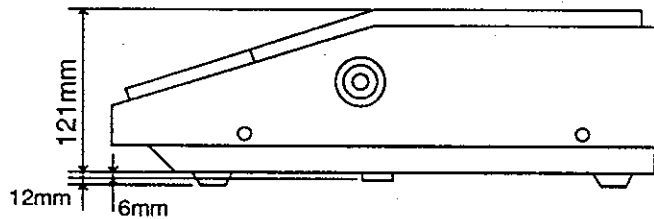
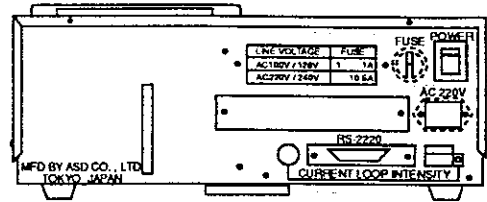
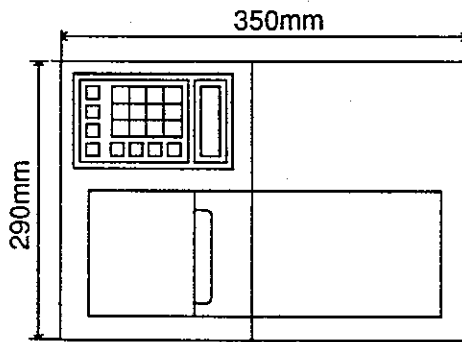

A&D

A&D Company, Limited

3-23-14 Higashi-Ikebukuro, Toshima-ku, Tokyo 170 Japan
Telephone: [81] (03) 5391-6132 Fax: [81] (03) 5391-6148 Telex: 2422816 AANDD J

A&D ENGINEERING, INC.

1555 McCandless Drive, Milpitas, CA. 95035 U.S.A.
Telephone: [1] (408) 263-5333 Fax: [1] (408) 263-0119

A&D INSTRUMENTS LTD.

Abingdon Science Park, Abingdon, Oxford OX14 3YS England
Telephone: [44] (0235) 550420 Fax: [44] (0235) 550485

A&D MERCURY PTY. LTD.

32 Dew Street, Thebarton, South Australia 5031 Australia
Telephone: [61] (08) 352-3033 Fax: [61] (08) 352-7409

A&D KOREA Limited

3rd Floor Hanam Bldg 44-27 Yoido-dong Youngdeungpo-ku Seoul, Korea
Telephone: [82] (02) 784-4264 Fax: [82] (02) 784-6557